

Flight Manual			
Pavaman Aviations Private Limited			
Issue No.	09	Version No.	1.9
Date	22/07/2024	Document Reference	PA - 8



Pavaman
Aviation

Flight Manual			
Pavaman Aviations Private Limited			
Issue No.	09	Version No.	1.9
Date	22/07/2024	Document Reference	PA - 8

TABLE OF CONTENTS

1. Introduction	7
1.1. Purpose of the flight manual	7
1.2. Drone make and model	9
1.3. Date of manufacture 12/09/2023	9
1.4. Owner / Operator PAVAMAN AVIATION	9
1.5. DGCA Registration number UAXXXXXXXXX	9
INSTRUCTION FOR UNPACKING & CONNECTION OF DRONE	10
2. Limitations	12
2.1. Operational envelope:	12
2.2. Regulatory Compliance:	12
2.3. Battery and Power:	12
2.4. Payload and Weight:	12
2.5. Speed and Altitude:	13
2.6. Wind Conditions:	13
2.7. Environmental Constraints:	13
2.8. Operating Conditions	13
2.9. Flight Range and Visibility:	14
3. Operating Procedures	16
3.1. Preflight Preparation	16
3.1.1. Battery And Charging	16
3.1.2. Flight Controls and Instruments Check	22
3.1.3. INSTRUMENTS CHECKLIST	23
3.1.4. Payload Installation	23
3.1.5. Check For Updates And Software	24
3.2. Take-off Procedures	26
3.3 Landing Procedures	26
3.1.1. Flight Control and Monitoring	28
3.1.2. Getting Started	29
3.1.3. Dashboard	30
3.1.4. Home Menu	39
3.1.5. Create a New Project	44
3.1.6. Select a Flying Method	45
4. Connecting a Drone	64
4.1. Communication Link setting:	65

Flight Manual			
Pavaman Aviations Private Limited			
Issue No.	09	Version No.	1.9
Date	22/07/2024	Document Reference	PA - 8

4.1.1. Serial Communication:	65
4.1.2. Baud rate:	65
4.1.3. Parity:	65
4.1.4. UDP (User Datagram Protocol):	66
4.1.5. TCP (Transmission Control Protocol):	67
4.1.6. Bluetooth	68
4.2. RPA Settings	68
4.3. Aircraft Settings	69
4.3.1. GEO- FENCE	72
4.4. Spraying System	72
4.4.1. Flow Meter Error Alert	77
4.4.2. Compass Calibration Settings	84
4.5. Safety	87
4.6. Field Plot Functionality	90
4.7. Using RC/Mobile	90
4.8. Using Drone	91
4.9. Using Map	91
4.10. Import KML	91
4.11. Mission Planning Functionality	92
4.11.1. Parameters	92
4.11.2. Adjust Waypoint	94
4.11.3. Adjust Spacing	95
4.11.4. Indentation	96
4.11.5. Adjust Route	97
4.12. Flyview	98
4.13. Dosage Calculation:	104
4.14. Report Generation	109
4.15. Landing Procedures:	111
4.15.1. Emergency Landing	111
4.15.2. Return To Launch	111
4.16. Postflight Procedures:	112
4.16.1. Payload Removal, Data Backup And Storage	112
4.16.2. Maintenance Checks	113
5. Emergency Procedures	114
5.1. Failsafe Triggers and RTL Procedure:	114

Flight Manual			
Pavaman Aviations Private Limited			
Issue No.	09	Version No.	1.9
Date	22/07/2024	Document Reference	PA - 8

5.2. Loss Of Communication	115
Fig 28: Dashboard showing 'GCS failsafe cleared'	117
Fig 29: Dashboard showing 'Communication link lost'	118
5.2.1. Loss Of Control / Stability Mid- Air	118
5.2.2. Low Battery Failure	118
5.2.3. LOSS OF VISUAL CONTACT WITH THE RPA	119
5.2.4. EMERGENCY LANDING	119
5.2.5. SUDDEN CHANGE IN WIND CONDITIONS	119
5.2.5.1. FLIGHT CONTROLLER SYSTEM FAILURES	120
5.2.6. IMU FAILURE	120
5.3. GPS FAILURE	120
5.4. COMPASS FAILURE	121
5.4.1. INCAPACITATION OF PILOT	121
5.5. Geofence Breach	121
5.6. Emergency Shutdown	121
6. Maintenance	123
6.1. Routine Maintenance Schedule	123
6.2. Maintenance Procedures	125
6.2.1. Battery Maintenance	125
6.2.2. Motor And Propeller Maintenance	126
6.2.3. Payload Maintenance	127
6.3. Troubleshooting Guide	127
6.4. Service And Support	128
7. Performance Data	128
7.1. Operational Envelope	128
7.2. Weight And Balance Information	129
7.3. Battery Life	130
7.4. Payload Performance	130
7.5. Safety Information	131
8. Safety Considerations	132
8.1. Risk Management	132
8.2. Operating In Restricted Airspace	132
8.3. Flight Termination Procedures	133
9. Technical Data:	133
9.1. Dimensions	133
9.2. Rpa Drawings	135

Flight Manual			
Pavaman Aviations Private Limited			
Issue No.	09	Version No.	1.9
Date	22/07/2024	Document Reference	PA - 8

9.3. Motor And Power Specifications	137
9.4. Battery Specifications	139
*Note: One set consists of two batteries of the above specification connected in series.	139
9.5. Control And Communication Description Specifications	140
9.6. Payload Specifications	142
9.7. Operation	144
9.8. Data logging	144
10. UAS Logbook	145
Appendices:	147
1. Contact Information for Service and Support	148
2. Recommended Reading and Resources	148
Annexure- 1	149
Annexure- 2	152
Annexure- 3	153

Flight Manual			
Pavaman Aviations Private Limited			
Issue No.	09	Version No.	1.9
Date	22/07/2024	Document Reference	PA - 8

1. Introduction

1.1. Purpose of the flight manual

A flight manual for an Agriculture drone is an essential document that provides pilots and other users with the information needed to operate the drone safely and efficiently. It serves as a comprehensive guide that covers all aspects of drone operation, including take-off and landing procedures, flight operations, emergency procedures, and maintenance. The flight manual includes detailed instructions and performance data that help pilots understand the capabilities and limitations of the drone and how to use them effectively. It serves as an important reference guide for pilots and operators, ensuring they have the necessary information to fly the drone safely, efficiently, and in compliance with regulations.

It serves as a reference guide for pilots and operators, providing them with the necessary information to fly the drone safely and efficiently.

Flight Manual			
Pavaman Aviations Private Limited			
Issue No.	09	Version No.	1.9
Date	22/07/2024	Document Reference	PA - 8



Figure 1: Pavaman Aviation Private Limited - TEJAS



Figure 2: Pavaman Aviation Private Limited - TEJAS

Flight Manual			
Pavaman Aviations Private Limited			
Issue No.	09	Version No.	1.9
Date	22/07/2024	Document Reference	PA - 8

1.2. Drone make and model

Pavaman Aviation Private Limited / Model Name:TEJAS

Model Number: PA001





- | | |
|-------------------------------|------------------|
| 1.3. Date of manufacture | 12/09/2023 |
| 1.4. Owner / Operator | PAVAMAN AVIATION |
| 1.5. DGCA Registration number | UAXXXXXXXXX |

The TEJAS unit in the box contains



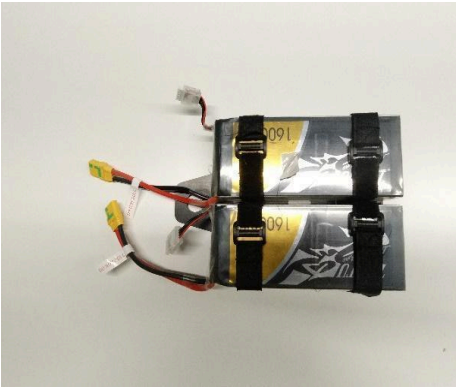
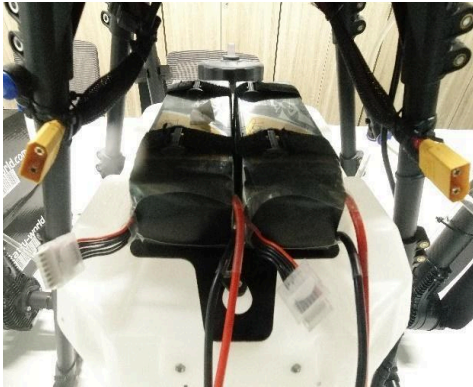

- TEJAS Drone
- Battery set-2 Nos,
- Battery Charger- 1 Nos.
- Transmitter Unit
- Transmitter charger
- Allen Key set
- Lipo checker
- Flight manual,
- User removable components maintenance manual,
- battery log book and
- drone operational log book

Flight Manual			
Pavaman Aviations Private Limited			
Issue No.	09	Version No.	1.9
Date	22/07/2024	Document Reference	PA - 8

INSTRUCTION FOR UNPACKING & CONNECTION OF DRONE

Unboxing the Drone	
1. Drone folded from the box	2. Extend the arm from the locking cap
	
3. Unfold the propeller blade	4. Unlock the battery tray
	
5. Strap the battery on the plate	6. Lock the battery tray on the tank
	

Flight Manual			
Pavaman Aviations Private Limited			
Issue No.	09	Version No.	1.9
Date	22/07/2024	Document Reference	PA - 8

Connecting the Drone	
7. Turn on the transmitter	8. Connect the battery to the drone
	
Disconnecting the Drone	
9. Disconnect the battery from the drone	10. Then turn off the transmitter
	

Flight Manual			
Pavaman Aviations Private Limited			
Issue No.	09	Version No.	1.9
Date	22/07/2024	Document Reference	PA - 8

2. Limitations

2.1. Operational envelope:

- Maximum Range: 500 meters
- Maximum Altitude: 30 meters AGL (Above Ground Level)
- Operating Temperature Range: 15°C to +50°C
- Endurance without dispensing payload at MTOW condition : 9 mins
- Endurance with dispensing payload at MTOW condition : 18 mins
- Endurance without variable payload (empty tank): 19 mins
- Flying condition: Visual Line Of Sight during daytime.
- Maximum wind speed: 6 m/s

2.2. Regulatory Compliance:

- Ensure compliance with The Drone Rules, 2021, Drone (Amendment) Rules, 2022, and India's aviation regulations and guidelines for unmanned aerial vehicles (UASs) during all flight operations.

2.3. Battery and Power:

- Critical Voltage: 42V (fixed parameter)
- Endurance without dispensing payload at MTOW condition : 9 mins
- Endurance with dispensing payload at MTOW condition : 18 mins
- Endurance without variable payload (empty tank): 19 mins

2.4. Payload and Weight:

- Maximum Payload Capacity: 8 kg

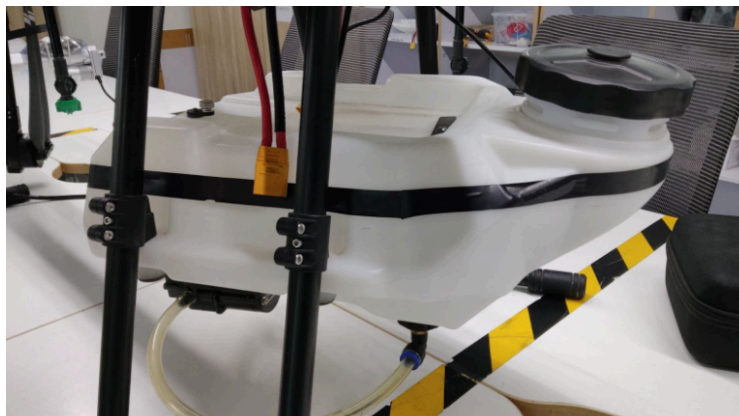

Note: The tank is not to be filled above 8 litre (i.e above the tape marked).

Flight Manual			
Pavaman Aviations Private Limited			
Issue No.	09	Version No.	1.9
Date	22/07/2024	Document Reference	PA - 8

- Maximum Take-off Weight (MTOW): 24.9 kg

2.5. Speed and Altitude:

- Maximum Operating Speed: 8m/s at standard sea level conditions
- Maximum Height: 30m (AGL)

2.6. Wind Conditions:

- Operate within the wind speed range of 0 to 6 m/s during flight.
- The drone's maximum bank angle is 20°.

2.7. Environmental Constraints:

- Daylight Operation: Flights should occur during daylight hours only.
- Avoid flight in adverse weather conditions such as rain or snow.
- Recommended operating conditions are within the specified temperature range for optimal performance.

2.8. Operating Conditions

TEJAS is to be flown only during the day time. It should not be flown in rain. Night flying should be avoided. Flying during rains should be avoided.

Important Notice: Ingress Protection (IP) Rating

This Unmanned Aerial System (UAS) has not undergone testing for Ingress Protection (IP) rating. The IP rating is a standard that defines the degree of protection provided by an enclosure against the intrusion of foreign objects, including dust and water. As a result, users are advised to exercise caution and avoid exposing the UAS to extreme environmental conditions, including heavy rain, dust storms, or immersion in water.

Note: This UAS is not certified to meet specific IP rating standards. Users should be mindful of the operating environment and take appropriate precautions to prevent potential damage due to exposure to moisture, dust, or other external elements. For any specific environmental requirements, consult the manufacturer or contact our technical support team.

Disclaimer: Operating the UAS outside of recommended environmental conditions may void warranties and could result in damage to the equipment. Users are encouraged to refer to the manufacturer's guidelines and exercise due diligence when considering the operating environment for the UAS.

Flight Manual			
Pavaman Aviations Private Limited			
Issue No.	09	Version No.	1.9
Date	22/07/2024	Document Reference	PA - 8

Important Notice: High-Intensity Radiated Fields (HIRF)

This Unmanned Aerial System (UAS) has not been designed or tested for operation in environments with High-Intensity Radiated Fields (HIRF). HIRF refers to electromagnetic fields with high levels of energy that may be present in certain industrial or radiofrequency-intensive settings.

Caution:

Using the UAS in environments with HIRF may pose risks to the proper functioning of electronic components and communication systems. The UAS is not equipped with specialized shielding or protection against HIRF, and its performance in such conditions is not guaranteed.

Note to Users:

Please refrain from operating the UAS in areas where HIRF exposure is likely, such as proximity to high-power radio transmitters, radar installations, or other sources of intense electromagnetic radiation. Consult with the manufacturer or contact our technical support team if you have specific concerns or questions regarding the operating environment.

Disclaimer: Operation of the UAS in environments with HIRF may lead to potential interference or damage to electronic systems. Users are advised to adhere to recommended operating conditions and consult with the manufacturer for additional guidance on environmental considerations.

2.9. Flight Range and Visibility:

- Maximum Range: 500 meters from the controller location.
- The drone should remain within visual line of sight (VLOS) at all times during flight operations.

Sr. No.	Limiting Criteria	Values
1	Maximum Take-off Weight	24.9 kg
2	Maximum Payload Weight	8 kg
3	Maximum Flight Duration with variable payload.	18 mins
4	Maximum Altitude	30 m (AGL)
5	Maximum Temperature Range	15° to +50°

Flight Manual			
Pavaman Aviations Private Limited			
Issue No.	09	Version No.	1.9
Date	22/07/2024	Document Reference	PA - 8

6	Maximum Wind Speed Range	0 to 6 m/s
7	Maximum Ceiling Height	30m (AGL)

Summary

- The TEJAS has a maximum operating speed of 8m/s at standard sea level conditions.
- The drone's operating temperature range is between 15 to +50° C.
- The drone's operational altitude is 30 m above ground level (AGL).
- The drone's operational envelope includes an altitude of 30 m AGL, a range of 500 m, a wind speed of less than 6 m/sec, and a drone speed of 8 m/sec.
- Endurance without dispensing payload at MTOW condition : 9 mins
- Endurance with dispensing payload at MTOW condition : 18 mins
- Endurance without variable payload (empty tank): 19 mins
- The drone's range is 500 m.
- The drone's maximum wind speed that can be withstood while on the ground is 0 to 6 m /sec.
- The drone's maximum bank angle is 20°.
- The drone is to be flown in daylight only.
- It should not be flown during night time.
- It should not be flown in rain or snow.
- The drone's maximum take-off weight (MTOW) is 24.9 Kg.

Flight Manual			
Pavaman Aviations Private Limited			
Issue No.	09	Version No.	1.9
Date	22/07/2024	Document Reference	PA - 8

3. Operating Procedures

3.1. Preflight Preparation

3.1.1. Battery And Charging

- The SkyRC PC1080 dual channel LiPo charger.
- This charger is capable of balancing charging 2 packs of 6 cell batteries simultaneously. It is specifically designed for a big battery pack.
- There are three working modes, fast charge, balance charge and storage .
- Master and Slave mode are available, enabling the user to perform synchronous settings for numerous (synchronize 2 or more) chargers via data cables.
- In addition, PC1080 has short-circuit, reverse polarity, and overheat protection to ensure maximum safety.

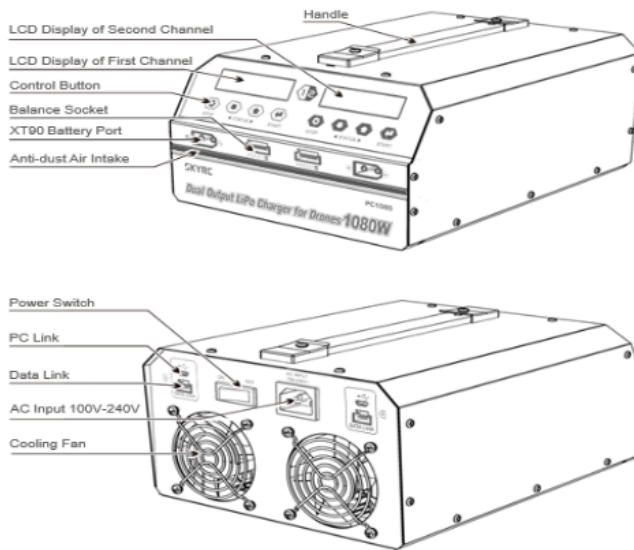

OPERATION PROCEDURE:

1. Power on: Connect to the power source and turn on the power switch. A beep sound will be heard, and the LCD screen will be displayed as below:





Flight Manual			
Pavaman Aviations Private Limited			
Issue No.	09	Version No.	1.9
Date	22/07/2024	Document Reference	PA - 8

- Battery connection: Please connect 16000mah batteries to PC1080 charger as below:(Note: Be aware that the Lithium battery to be charged should be 6 cells. Make sure the battery balance lead and charging lead are connected correspondingly to the charger.)

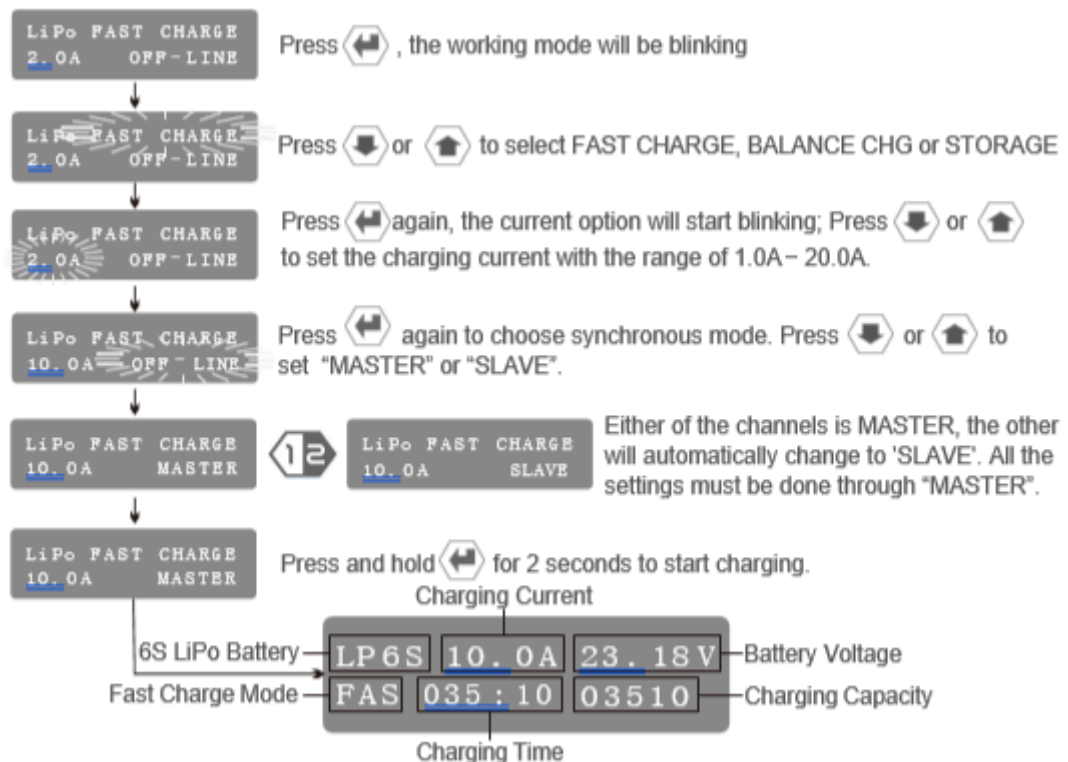

- Parameters settings



- Stop: if you'd like to terminate charging during the charging process, Press . Under Master-Slave mode, any operation must be carried out on the master channel.
- Finish: In charging mode, when the charging process comes to an end, the screen will be displayed as below.

<h1>Flight Manual</h1>			
<h2>Pavaman Aviations Private Limited</h2>			
Issue No.	09	Version No.	1.9
Date	22/07/2024	Document Reference	PA - 8



Battery Storage

- For safe handling, storage, and transportation of the battery, please support to the following guidelines:
- Never let the battery near to liquid material, and don't store the battery in a humid environment. Use LiPo Bags to get the controlled environment.
- Always use LiPo safe bags to store the battery.
- Physically damaged LiPo bags should not be used to store batteries.
- Never store Batteries to extreme temperatures or direct sunlight. The battery should be stored within $-10^{\circ}\text{C} \sim 45^{\circ}\text{C}$ range environmental conditions. Store the battery in an airconditioned room to maintain temperature and humidity.
- The battery should always be stored in a LiPo safe bag in order to maintain temperature and humidity. Before storing in a LiPo safe bag, ensure that the LiPo safe bag is not damaged and has no cut or any other damage exposing the LiPo battery stored inside to the outside environment. In case the LiPo bag is damaged, dispose of the damaged lipo bag and use a new one.
- Never let the battery close to fire and some heating machines and other things that can catch fire.
- Keep the battery where children can't touch.
- Keep the battery at 25°C temperature.
- Keep the battery in an open environment, make sure there's enough space for the battery storage. (The battery can't be squeezed by the battery).
- Make sure to check the storage every two weeks. And Keep the battery in charging/ discharge battery to storage mode.
- If a Lithium battery is not used for more than 3 days, it's highly recommended to charge or discharge the battery to 3.9V with STORAGE mode so as to extend the battery life.
- If the battery voltage is higher than 3.9V, the charger will discharge the battery: if the battery voltage is less than 3.9V per cell the charger will charge the battery under STORAGE mode.



Flight Manual			
Pavaman Aviations Private Limited			
Issue No.	09	Version No.	1.9
Date	22/07/2024	Document Reference	PA - 8

- Click ON the ↑ (upward arrow) then the charging modes will be elected then press the upward arrow key till the storage mode is selected and then click ON start button to start button and the charging process begins.
- Before engaging storage mode, ensure your batteries are at their recommended state of charge for storage. For most lithium-ion batteries, this is typically around 50% to 70% of their full capacity. If your batteries are fully charged, you might need to discharge them slightly before activating storage mode. Conversely, if they're nearly empty, you might need to charge them slightly.



- Take down the temperature reading while starting off discharging the batteries.

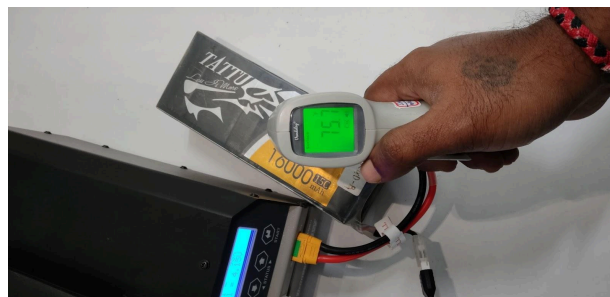

- After the discharging process completes it indicates finish then click on stop.



- Even when not in use, it's essential to periodically check the condition of your batteries and perform any recommended maintenance procedures to ensure their longevity and performance.

Balance Charge:

Flight Manual			
Pavaman Aviations Private Limited			
Issue No.	09	Version No.	1.9
Date	22/07/2024	Document Reference	PA - 8

- Click ON the ↑ (upward arrow) then the charging modes will be elected then press the upward arrow key till the balance charge mode is selected and then click ON start button to start button and the charging process begins.



- The finish indicates that the charging process is completed. Then click on the stop button and the process will end. It indicates the voltage value of 25.20v for a single battery.



Fast Charge:

- Click ON the ↑ (upward arrow) then the charging modes will be elected then press the upward arrow key till the fast charge mode is selected and then click ON start button to start button and the charging process begins.



Flight Manual			
Pavaman Aviations Private Limited			
Issue No.	09	Version No.	1.9
Date	22/07/2024	Document Reference	PA - 8

Recommended charging settings:

- No. of cell : 6
- Voltage : 22.2 V
- Current : 8 A
- Mode : Charge / Balance Charge
- Battery type : LiPo

Flight Manual			
Pavaman Aviations Private Limited			
Issue No.	09	Version No.	1.9
Date	22/07/2024	Document Reference	PA - 8

3.1.2. Flight Controls and Instruments Check

Sr.No.	FLIGHTS CONTROLS DESCRIPTION	Checklist	Remarks
1	Verify that all arms are securely attached to the centre frame.	Yes () / No ()	
2	Check for any play movement between the boom and folding mechanism.	Yes () / No ()	
3	Inspect the centre airframe for structural anomalies and loose or missing parts.	Yes () / No ()	
4	Inspect the booms for any damage or wear to the carbon fibre tubes, paying close attention to the junctions at each end.	Yes () / No ()	
5	Check for play between each motor mount and boom, and between the motor bell and base.	Yes () / No ()	
6	Spin the motors by hand to check for smooth rotation and inspect the motor bells for any dents or scratches.	Yes () / No ()	
7	Inspect the propellers for correct attachment to the hub, pitch play, wear, damage, or warping.	Yes () / No ()	
8	Verify that the propellers are clear of surrounding structures and other propellers as they rotate through their full range of motion.	Yes () / No ()	
9	Test and log the voltage of each battery pack and inspect the batteries for signs of damage or swelling.	Yes () / No ()	
10	Inspect the battery connectors and leads for wear or damage and ensure all batteries are securely attached to the battery tray.	Yes () / No ()	
11	Verify that the battery plate is securely attached to the airframe and that the landing gear is correctly oriented and attached to the airframe.	Yes () / No ()	
12	Check that the GPS and control link antennas are securely fastened and correctly oriented.	Yes () / No ()	
13	Verify that the RPA indication lights on the end of each boom are functioning properly.	Yes () / No ()	
14	Inspect the control sticks for free movement and check for dust or debris.	Yes () / No ()	

Flight Manual			
Pavaman Aviations Private Limited			
Issue No.	09	Version No.	1.9
Date	22/07/2024	Document Reference	PA - 8

15	Calibrate control sticks and inputs if necessary.	Yes () / No ()	
16	Verify that the RPS battery levels are sufficient for the duration of operation.	Yes () / No ()	
17	Check that the RPA failsafe is properly set for the type of operation and environment.	Yes () / No ()	

3.1.3. INSTRUMENTS CHECKLIST

Sr. No	INSTRUMENTS	CHECKLIST
1	Allen Key	Yes () / No ()
2	Zip Ties	Yes () / No ()
3	Double side Tape	Yes () / No ()
4	Knife/ Scissors	Yes () / No ()
5	Phone/ Tablet	Yes () / No ()
6	Battery charger	Yes () / No ()
7	Spirit Leveller	Yes () / No ()
8	LiPo checker/Multimeter	Yes () / No ()

3.1.4. Payload Installation

1	Inspect the payload attachment points and ensure that anti-drop clips are in place, if used.	Yes () / No ()	
2	Check the payload does not exceed 8 litres. check power cables and connectors for pump, flow meter and level sensor.	Yes () / No ()	

Flight Manual			
Pavaman Aviations Private Limited			
Issue No.	09	Version No.	1.9
Date	22/07/2024	Document Reference	PA - 8

3.1.5. Check For Updates And Software

■ Updating

- Need for software Upgradation.
- software upgradation is required because of the following situations:
 - To fix the bugs
 - To avoid hacks
 - Rolling out the new features
 - Security improvement
 - Interaction with new media
 - To prevent the loss of a drone
 - Optimise the performance of the device.

■ Process of Upgradation

Update Alert: AeroGCS GREEN app will give the alert of a new version available as shown in the following image.

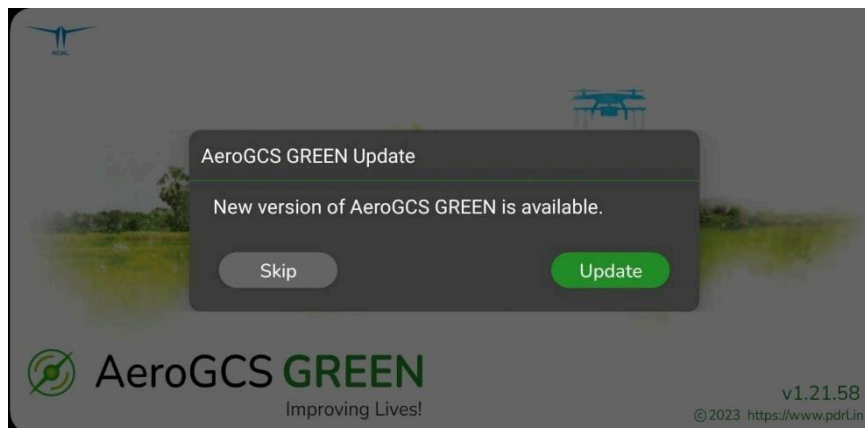

Figure 3 : AeroGCS GREEN update

Click on the "Update" button to get the updated version of AeroGCS GREEN. Then the user can use the app smoothly.

Note: The important flight parameters which may affect compliance are statically defined in firmware binary itself while compiling firmware.

These parameters can't be changed by any method from any GCS software.

Therefore, here are important ways implemented for securing flight parameters.

- 1) Critical parameters are statically defined by making firmware binary.
- 2) The firmware is digitally signed and monitored for any change. If change happens, it doesn't allow us to proceed further.

Flight Manual			
Pavaman Aviations Private Limited			
Issue No.	09	Version No.	1.9
Date	22/07/2024	Document Reference	PA - 8

- 3) Firmware and AeroGCS software both are tightly coupled with each other so that no other GCS can connect to firmware using a Telemetry device.
- 4) The feature of allowing critical parameter change is not available with the user of the drone. Therefore, there is no way any AeroGCS user can make changes to any secure critical parameters of the drone.

Flight Manual			
Pavaman Aviations Private Limited			
Issue No.	09	Version No.	1.9
Date	22/07/2024	Document Reference	PA - 8

3.2. Take-off Procedures

■ **Take-off:**

- Maintain a distance of at least 5 metres from the drone before launch.
- Make sure the drone is on a level and stable surface before take-off.
- Perform a pre-flight check of the drone, including inspecting the batteries, propellers, and other components for proper function.
- Check the weather conditions and avoid take-off if the wind speed is above a certain limit.
- Check for any obstacles or other potential hazards in the take-off area.
- Ensure that the drone is properly calibrated, and the GPS signal is strong before take-off.
- Always take off and land the drone in an open space.
- Always take off and land the drone in the direction of the wind.

3.3 Landing Procedures

■ **Landing:**

- Never attempt to land the drone on uneven or unstable ground.
- Always land the drone in an open space.
- Always land the drone in the direction of the wind.
- Perform a pre-landing check of the drone, including inspecting the batteries, propellers, and other components for proper function.
- Check the weather conditions and avoid landing if the wind speed is above a certain limit.
- Check for any obstacles or other potential hazards in the landing area.
- Always maintain a safe distance from the drone while landing.
- Always disarm and switch off the drone after landing.

Please note that these are general guidelines. It is recommended to check with the local aviation authorities for the specific regulations in your area.

Flight Manual			
Pavaman Aviations Private Limited			
Issue No.	09	Version No.	1.9
Date	22/07/2024	Document Reference	PA - 8

➤ Shock Absorption Mechanism

Attention Pilots:

This UAS (Hexacopter) does not incorporate a shock absorption mechanism. Pilots are advised to exercise caution during takeoff, landing, and in-flight operations to prevent damage to sensitive components and ensure optimal performance.

➤ **Do's and Don'ts:**

Do's:

1. Smooth Landings: Execute gentle landings to minimize impact on the UAS.
2. Pre-flight Inspection: Conduct a thorough pre-flight inspection, paying attention to any signs of wear or damage.
3. Controlled Takeoffs: Implement controlled takeoffs to avoid sudden jolts to the UAS.
4. Post-flight Check: Inspect the UAS after each flight for any signs of stress, especially in the landing gear.

Don'ts:

1. Hard Landings: Avoid abrupt or hard landings that may transmit excessive force to the UAS structure.
2. Collision: Steer clear of collisions with obstacles or surfaces during flight.
3. Rough Handling: Refrain from rough handling of the UAS during transportation and maintenance.

Note: The absence of a shock absorption mechanism necessitates careful handling to prevent structural damage and ensure the longevity of the UAS components.

Flight Manual			
Pavaman Aviations Private Limited			
Issue No.	09	Version No.	1.9
Date	22/07/2024	Document Reference	PA - 8

3.1.1. Flight Control and Monitoring



Fig 4: The AeroGCS GREEN Flight View Panel

Tejas is a Remotely Piloted Aircraft. TEJAS operates on AeroGCS application for Flight control and Monitoring. The settings of various parameters to the specified values and conditions are mandatory before it comes into operation.

Once logged in, the user may use shortcuts for handling the drone operations. Various options available on the dashboard indicated in the following image.

The features, Functionality and Procedures for using AeroGCS GREEN are as follows:

Flight Manual			
Pavaman Aviations Private Limited			
Issue No.	09	Version No.	1.9
Date	22/07/2024	Document Reference	PA - 8

Features of AeroGCS GREEN:

- Equal and Uniform Spraying
- Calculate and control the dosage of liquid Avoid spraying in a neighbouring field.
- Precise tracking and resuming non-completed flights.
- Plot spraying missions on the field and perform mission planning on cloud Generate and share spraying field reports easily.
- Obstacle avoidance to perform efficient spraying Optimization of resources.

Operating System requirements: Android versions above 10

3.1.2. Getting Started

Download the app from the Google Play store on your mobile. Install it on your mobile. Open the app to use for agriculture spraying.

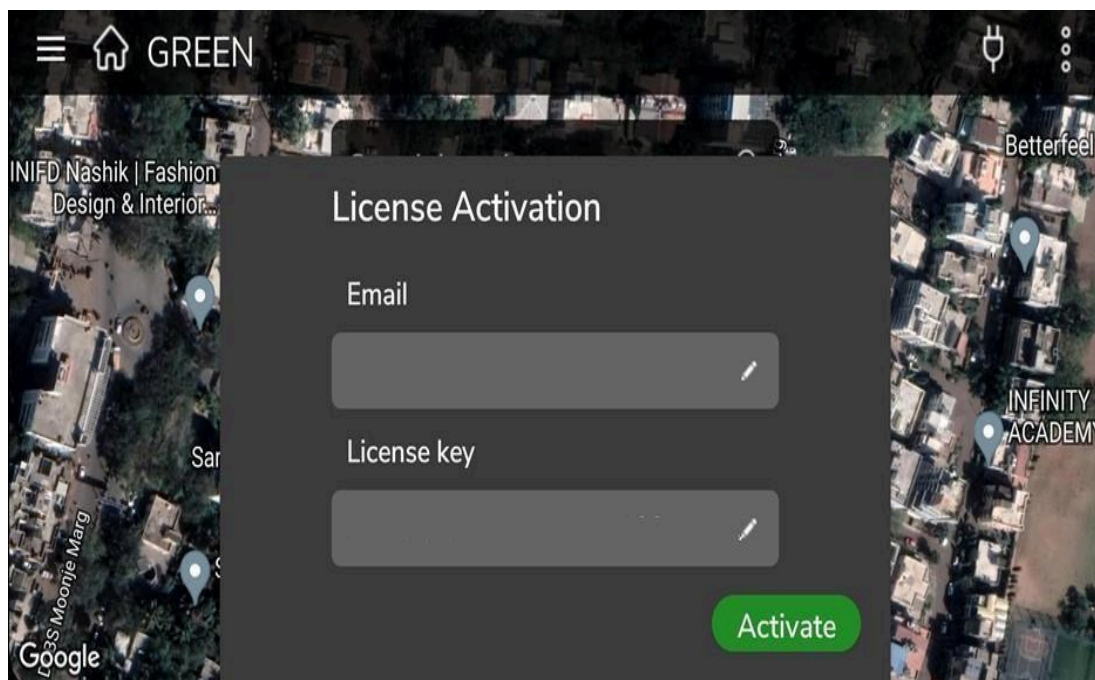

Figure 5 : License Activation

Enter an authentic email address and License key provided to you. After entering the details click on the “Activate” button to activate your app.

Once activated you can use this app with all its features. Update Alert:

AeroGCS GREEN app will give the alert of a new version available as shown in the following image.

<h1>Flight Manual</h1>			
<h2>Pavaman Aviations Private Limited</h2>			
Issue No.	09	Version No.	1.9
Date	22/07/2024	Document Reference	PA - 8

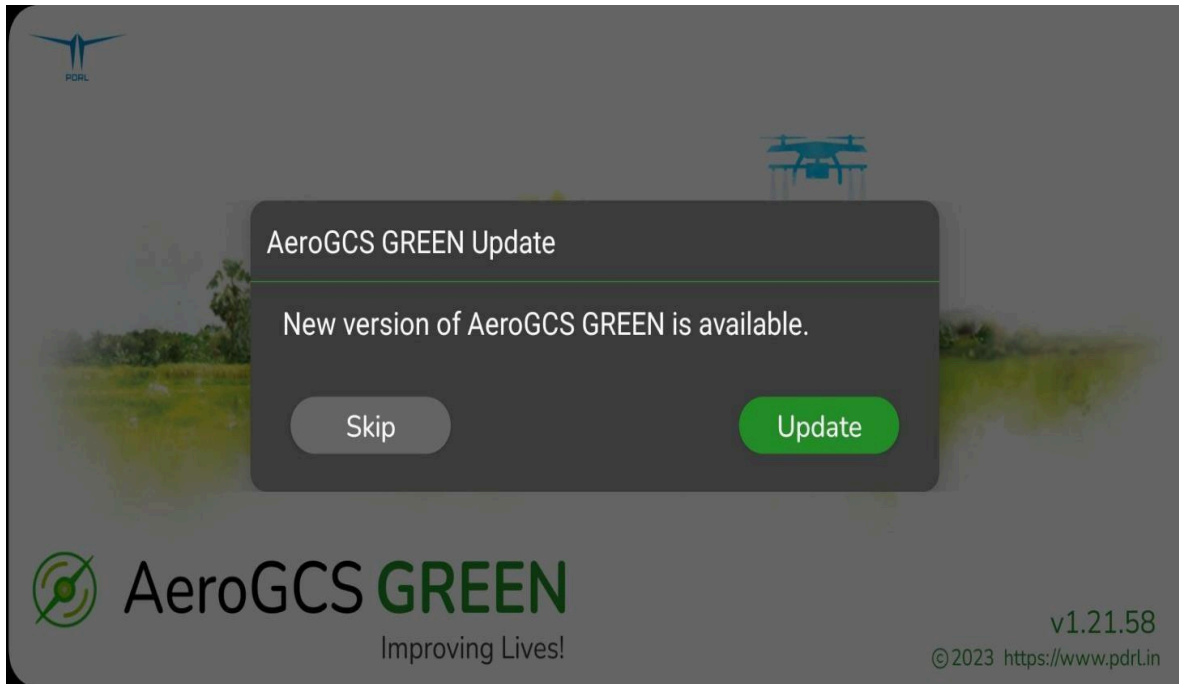

Figure 6 : Update Alert

Click on the "Update" button to get the updated version of AeroGCS GREEN. Then the user can use the app smoothly.

3.1.3. Dashboard

Dashboard of AeroGCS GREEN contains various controls as shown in the following image.

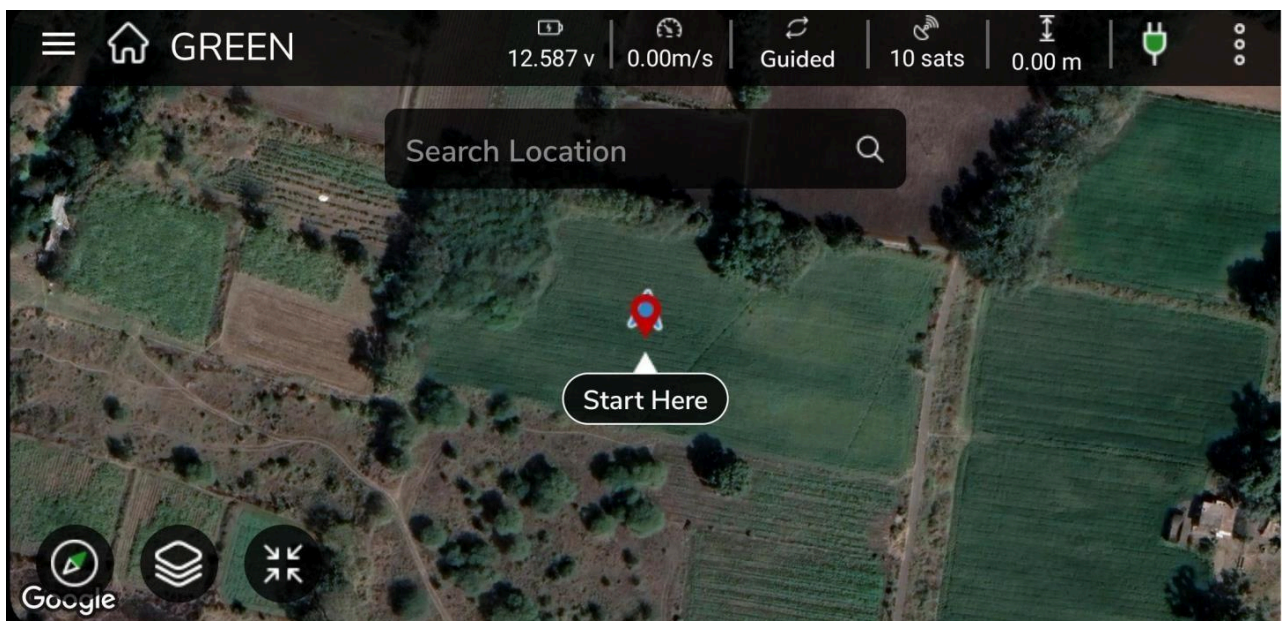



Figure 7 : Dashboard

Flight Manual			
Pavaman Aviations Private Limited			
Issue No.	09	Version No.	1.9
Date	22/07/2024	Document Reference	PA - 8

1. Click on  the symbol at the left-hand top corner to get the details of already available projects as shown in the following image.

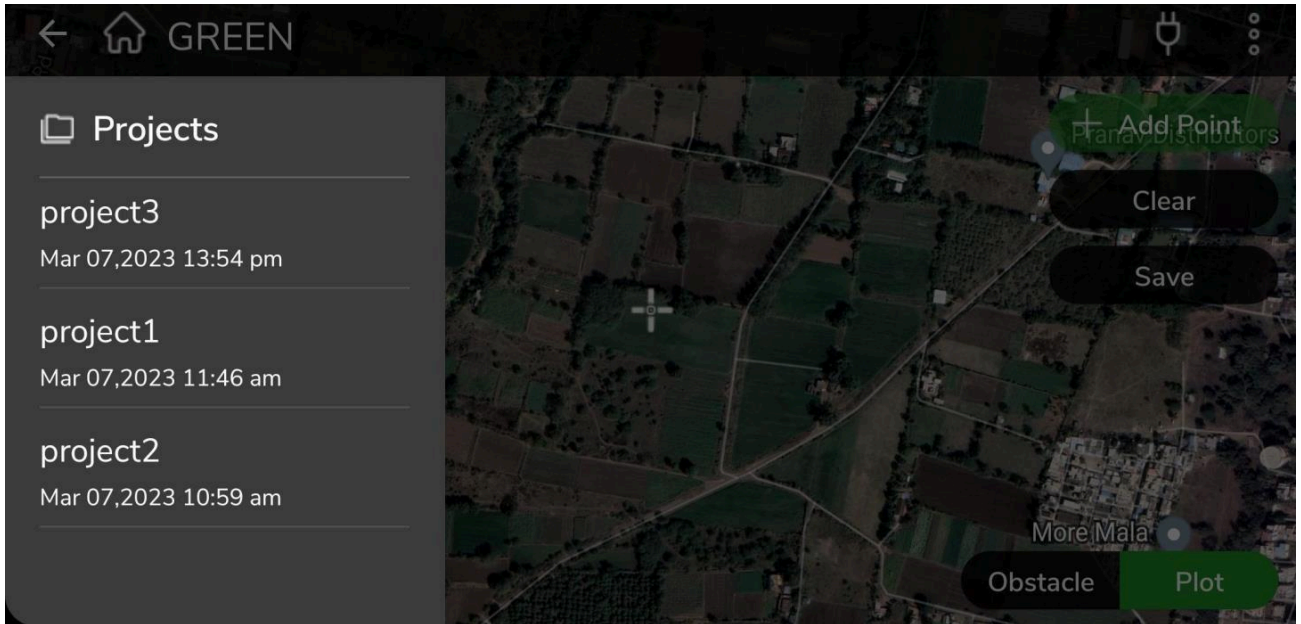

Figure 8 : Selection of Project from Dashboard

To open an existing project, click on the name of the project and you will be able to select either plans or plots available in the respective project.

Flight Manual			
Pavaman Aviations Private Limited			
Issue No.	09	Version No.	1.9
Date	22/07/2024	Document Reference	PA - 8

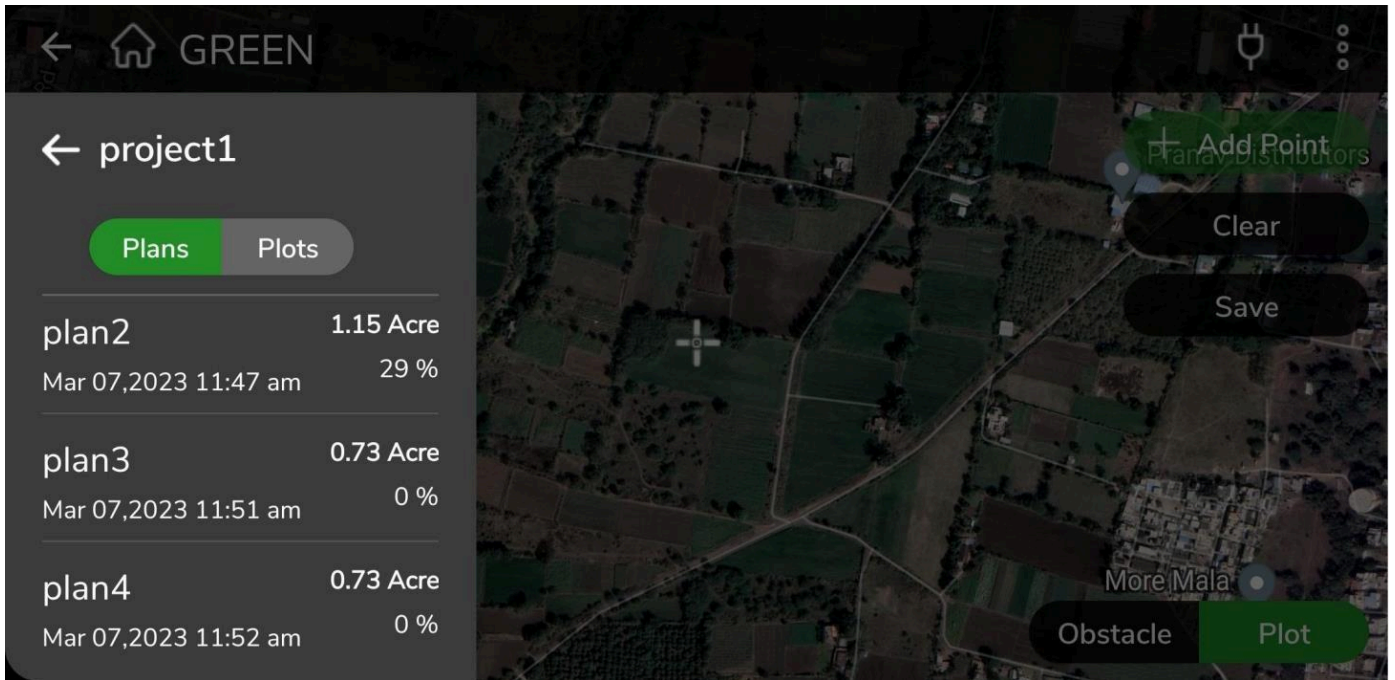

Figure 9 : Selection of Plans

- It shows the details of the selected project such as the total area covered in Acres and the percentage of flight status. You can select either plans or plots present in the selected project by scrolling the respective bar. By clicking on the name of the project here, the plan or plot will be displayed on the screen as shown in the following image.

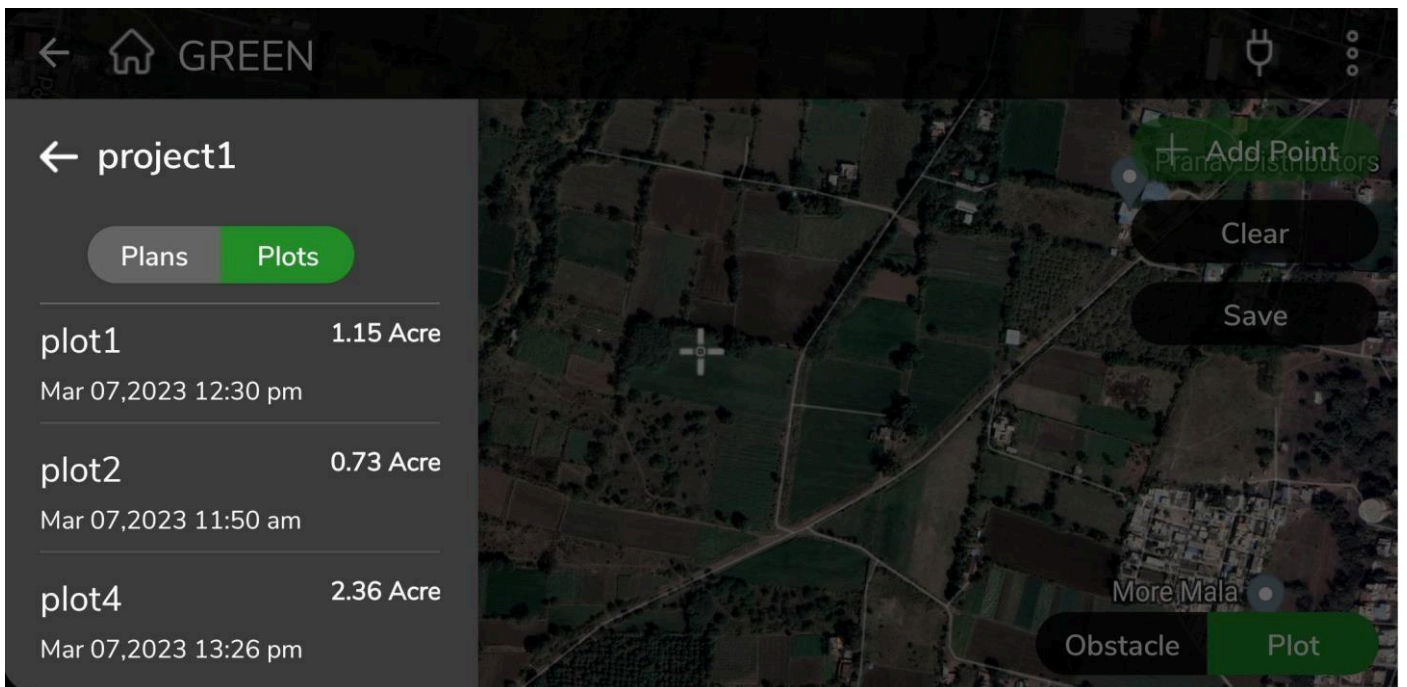



Figure 10 : Selection of Plots

Flight Manual			
Pavaman Aviations Private Limited			
Issue No.	09	Version No.	1.9
Date	22/07/2024	Document Reference	PA - 8



Figure 11 : Open an Existing plan

The user can edit the parameters as well as fly the drone on the same area with a same mission plan to save time.

1. Select any existing plan or plot to use for the flight.
2. Click on  icon to get the details of existing projects as well as to create a new project. Click on  to create a new project.

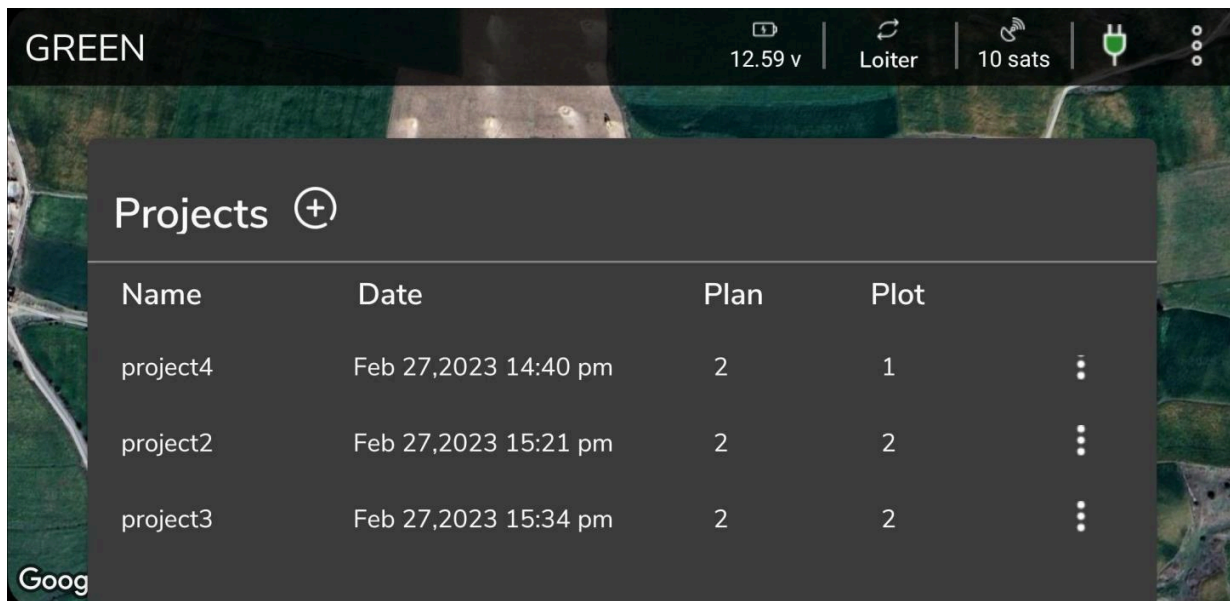



Figure 12 : Create a new Project

Flight Manual			
Pavaman Aviations Private Limited			
Issue No.	09	Version No.	1.9
Date	22/07/2024	Document Reference	PA - 8

Battery Voltage:

This icon shows the  battery voltage which is required to track a battery voltage.

3. **Mode of operation:** 

The dashboard shows the mode of operation of a drone.

4. **Number of Active Satellites:** 

The number of active satellites is shown here which are required to connect and communicate with a drone with GCS.

5. **Connecting a Drone:**



To fly the drone on the desired mission plan there should be proper connection between the drone  and GCS software.  The green color in this icon indicates that the drone is connected properly. If it is not connected it will be shown as .



Figure 18 : List of Plans from Dashboard

When the “create a new plan” option is selected then the user has to enter the details of the plan so that it can be stored in the respective project.

<h1>Flight Manual</h1>			
<h2>Pavaman Aviations Private Limited</h2>			
Issue No.	09	Version No.	1.9
Date	22/07/2024	Document Reference	PA - 8



Figure 19 : Added Plan to a project

Toggle the bar to save a plot in the project. After editing the plot, the user can save the plot as a new plot or changes will be saved to the existing plot.

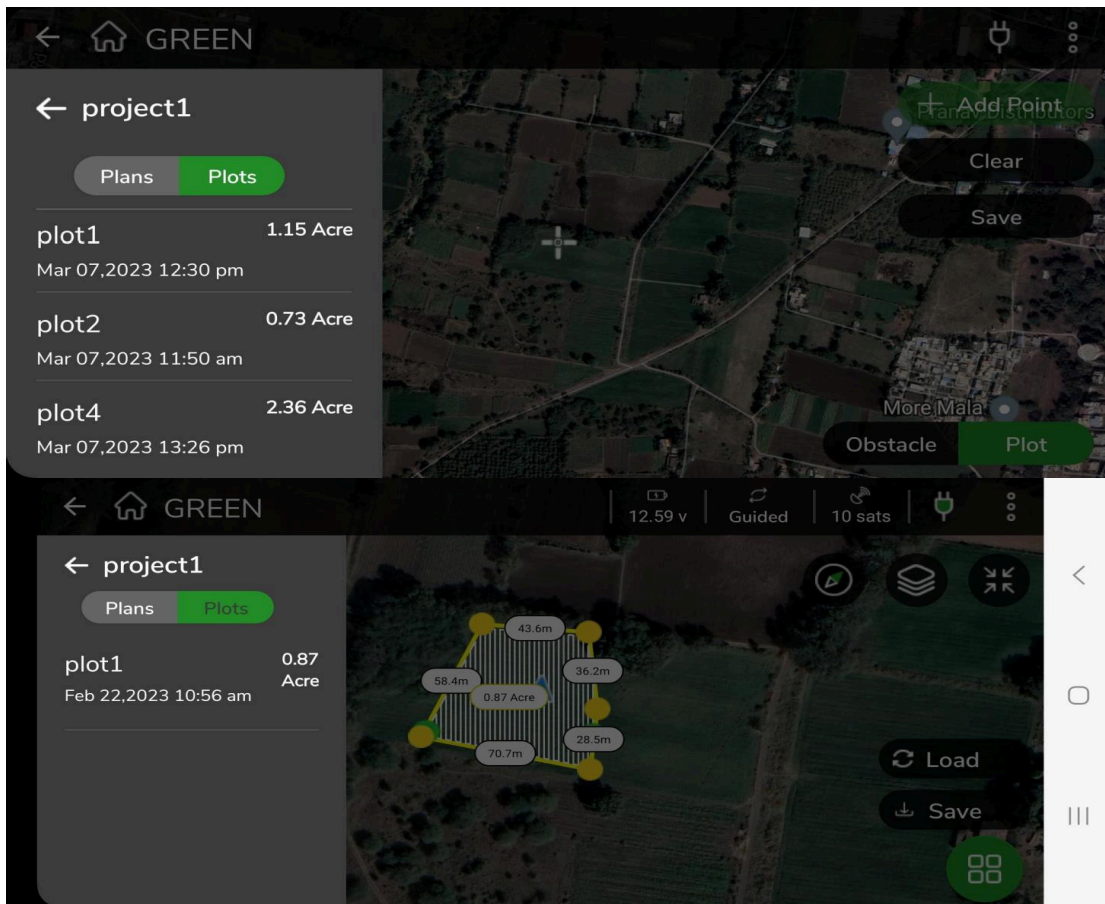

Figure 20 : Open Existing Plot

The corresponding plan or plot will be added to the list as shown in the image.

<h1>Flight Manual</h1>			
<h2>Pavaman Aviations Private Limited</h2>			
Issue No.	09	Version No.	1.9
Date	22/07/2024	Document Reference	PA - 8

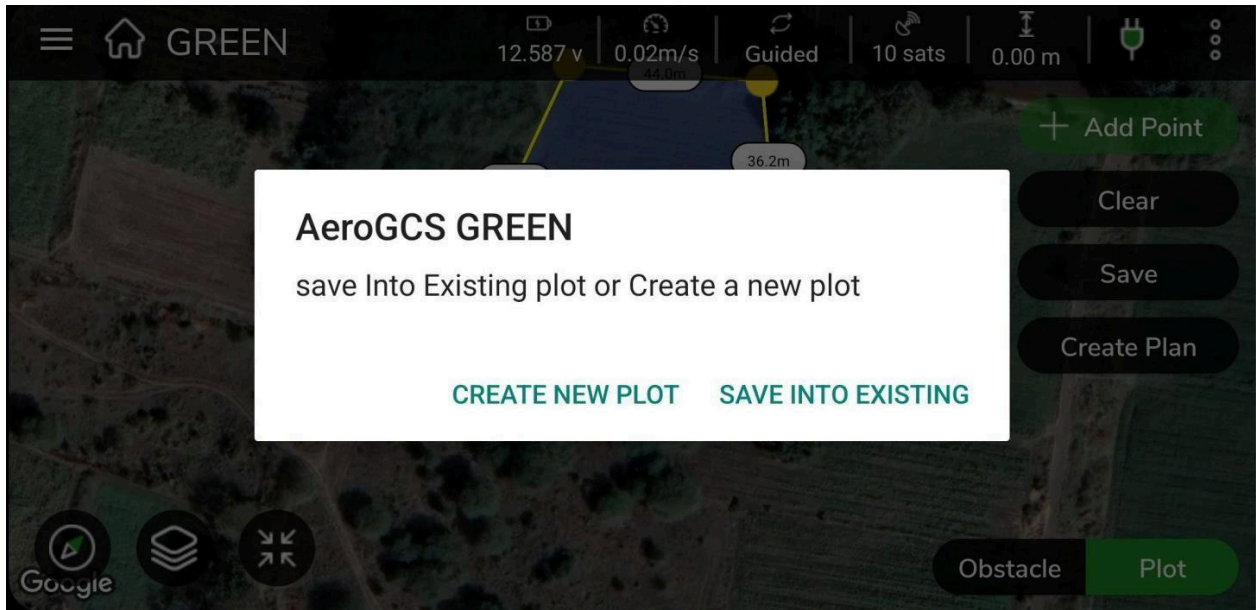

Figure 21 : Create and Save a new Plot

By using the 'Edit' and 'Save' options, the user can save multiple plots to a plan and multiple plans to a project.



Figure 20 : Create and Save a multiple Plans and Plot

<h1>Flight Manual</h1>			
<h2>Pavaman Aviations Private Limited</h2>			
Issue No.	09	Version No.	1.9
Date	22/07/2024	Document Reference	PA - 8

Dashboard controls:

After adding a plot



 This icon shows the direction of a nose of a drone. It gets aligned according to the direction of the nose of a drone in the air.

 This icon shows either a layered view or a plain view of the map. Normally, a hybrid view is displayed on the map.

Flight Manual			
Pavaman Aviations Private Limited			
Issue No.	09	Version No.	1.9
Date	22/07/2024	Document Reference	PA - 8



Figure 21 : Hybrid Layered View

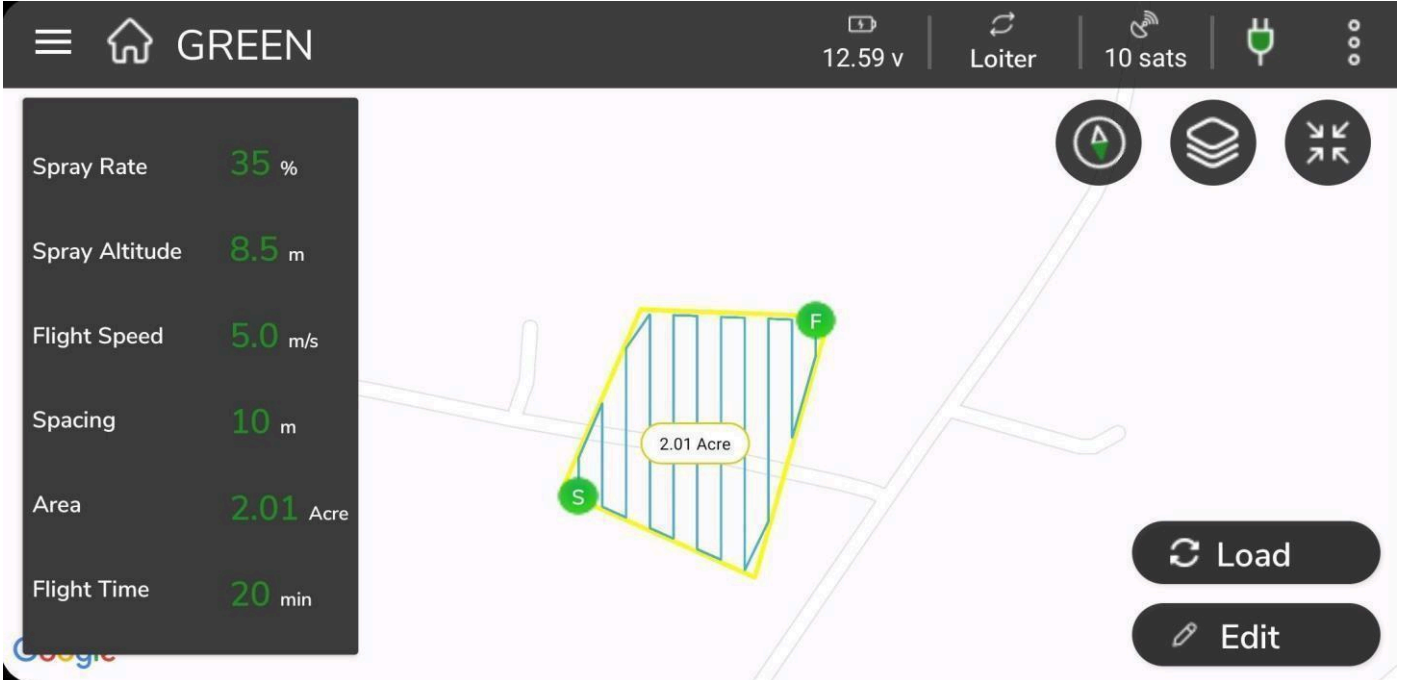

Figure 21 : Plain Layered View

Flight Manual			
Pavaman Aviations Private Limited			
Issue No.	09	Version No.	1.9
Date	22/07/2024	Document Reference	PA - 8

- This icon from the dashboard will show the position of the drone by centering on the map.

3.1.4. Home Menu

The 'Home' Menu of AeroGCS GREEN is simple to operate that provides the different features as discussed below:

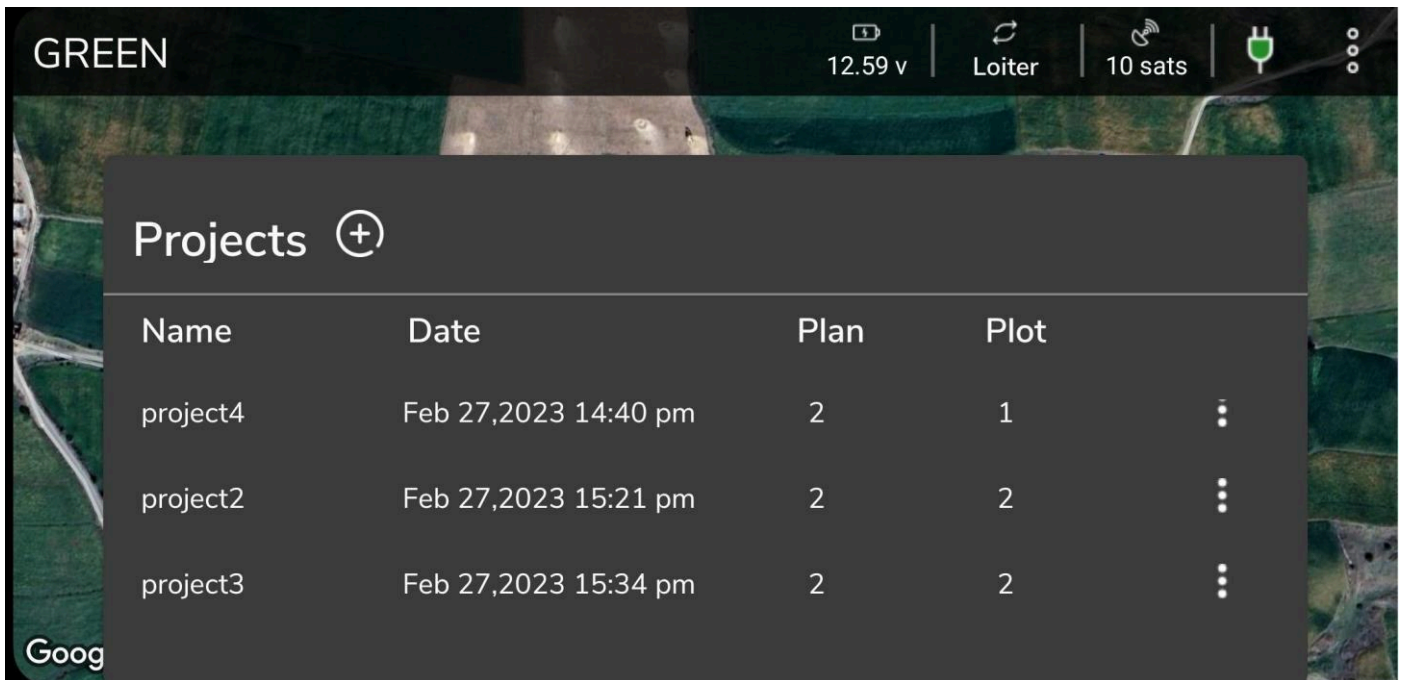



Figure 22 : Handling Projects

1. Projects

Click on  to have the information related to projects. The list of all the existing projects will be displayed on the screen with details such as date, number of plans, and plots present in that specific project as shown in the above image.

Select the project to see the details, you will get the information as shown below:

Flight Manual			
Pavaman Aviations Private Limited			
Issue No.	09	Version No.	1.9
Date	22/07/2024	Document Reference	PA - 8

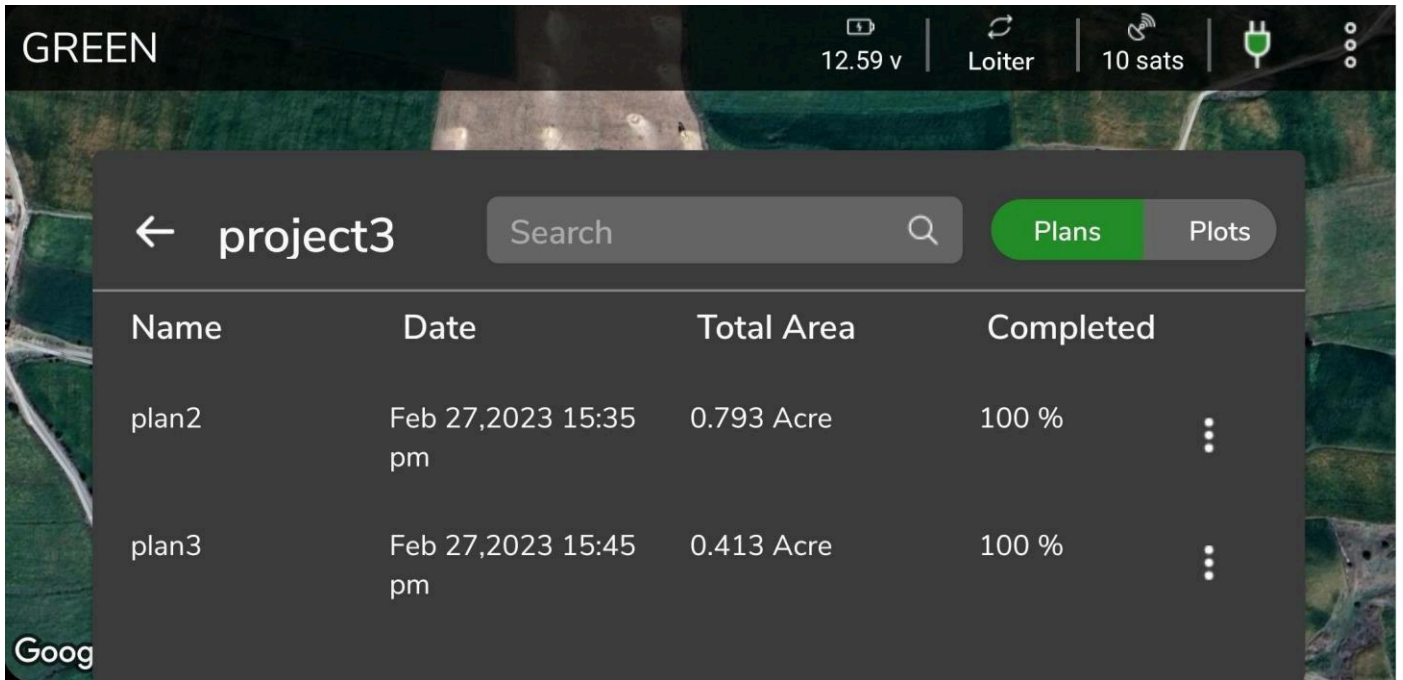

Figure 23 : Details of Selected Project

Details include the date of creation for a project and the area of the plan for that specific flight. The user can select either plot or a plan to observe the details.

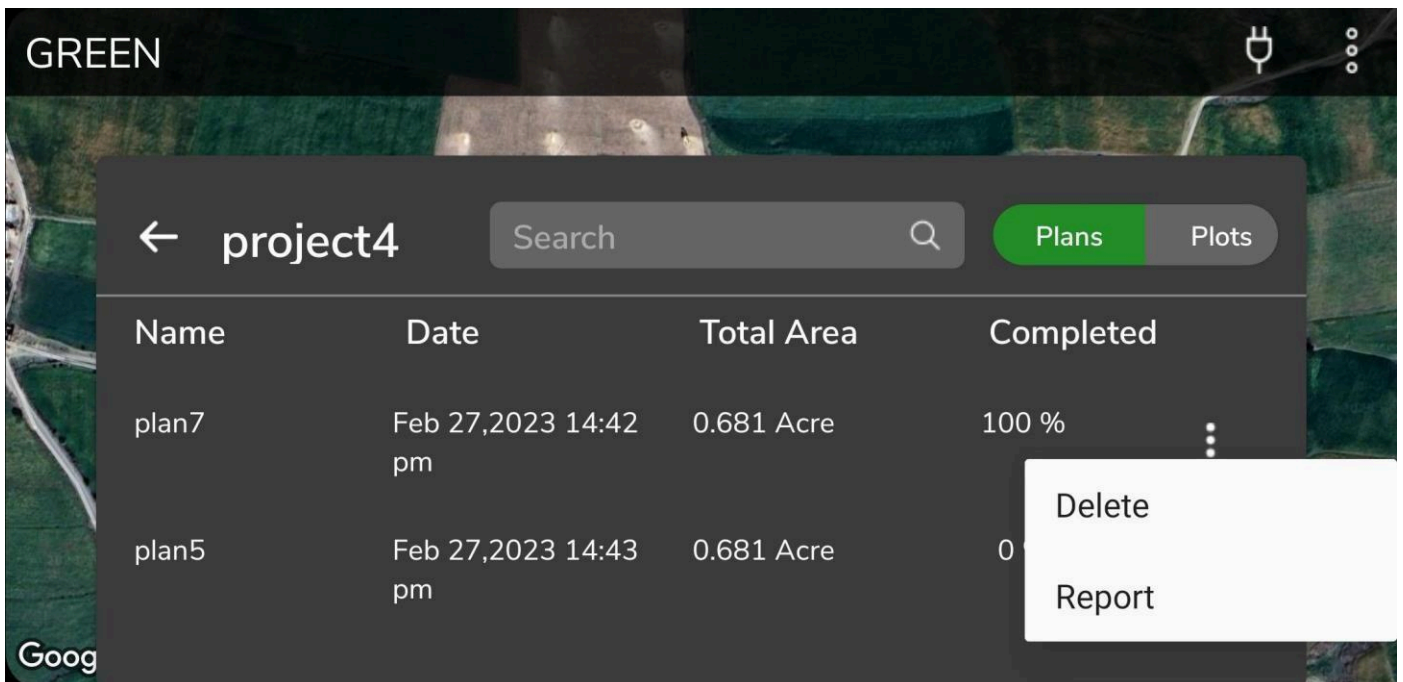

Figure 24 : Operations on the Project

Flight Manual			
Pavaman Aviations Private Limited			
Issue No.	09	Version No.	1.9
Date	22/07/2024	Document Reference	PA - 8

Delete the Plan: The selected plan can be deleted permanently. Once deleted, the plan cannot be recovered therefore AeroGCS GREEN will get it confirmed before actual deletion. A popup message will be displayed on the screen. Once the user presses 'YES' then that selected plan will be deleted.

Report the Plan: The user will have the report of the selected plan or plot as shown in the image below:

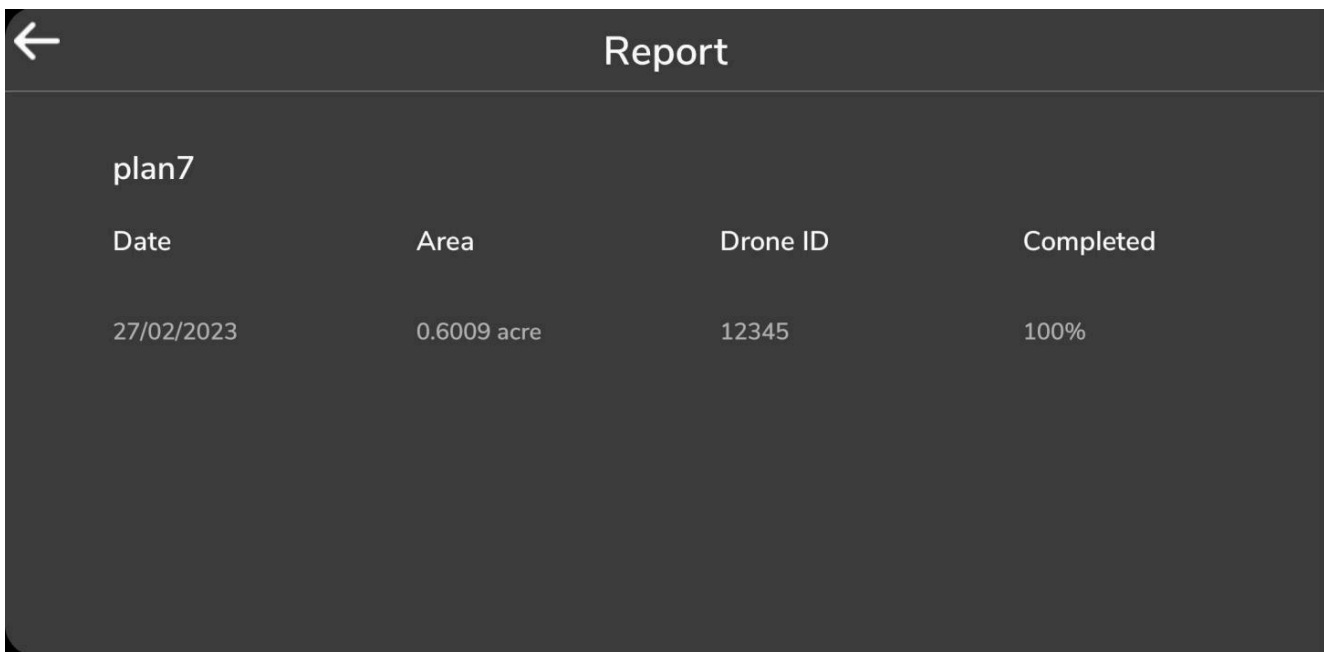

Figure 25 : Report of aPlan

A date-wise report of the plan will be readily available for the user. Here other details such as the area covered by a plan, drone used for the flight and competition status is also displayed. The AeroGCS GREEN allows the user to resume the flight from the earlier location where it was abrupted due to certain reasons.

Flight Manual			
Pavaman Aviations Private Limited			
Issue No.	09	Version No.	1.9
Date	22/07/2024	Document Reference	PA - 8

Click on the data field to get more details of the field report as shown in image below:

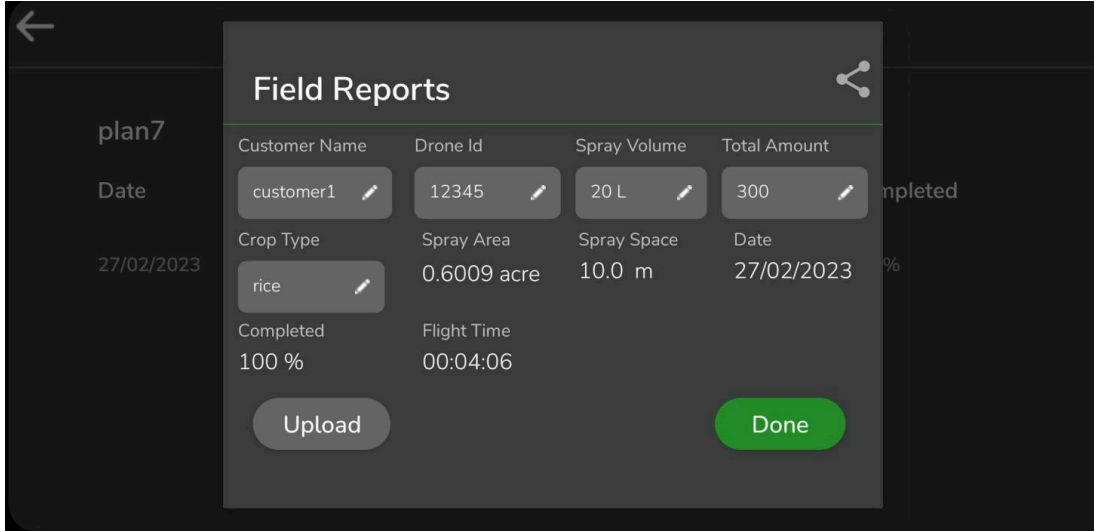



Figure 26 : Field Report

Field report includes the customer’s name, drone id, crop type, total flight time, and other details related to spraying such as spray area, spray space, and spray volume, etc. The user may edit a few data here such as customer name, Drone id, and crop type.

This  icon is used to share field reports. This field report can be shared through any apps or through mail service available on the mobile as follows:

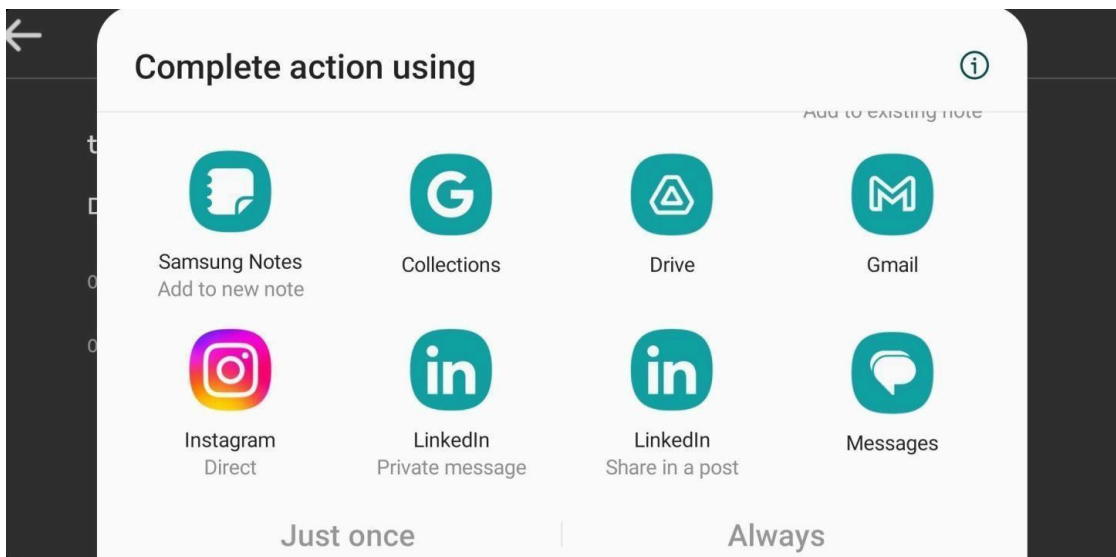

Figure 27 : Sharing Options

The image shows the shared report send through email.

<h1>Flight Manual</h1>			
<h2>Pavaman Aviations Private Limited</h2>			
Issue No.	09	Version No.	1.9
Date	22/07/2024	Document Reference	PA - 8

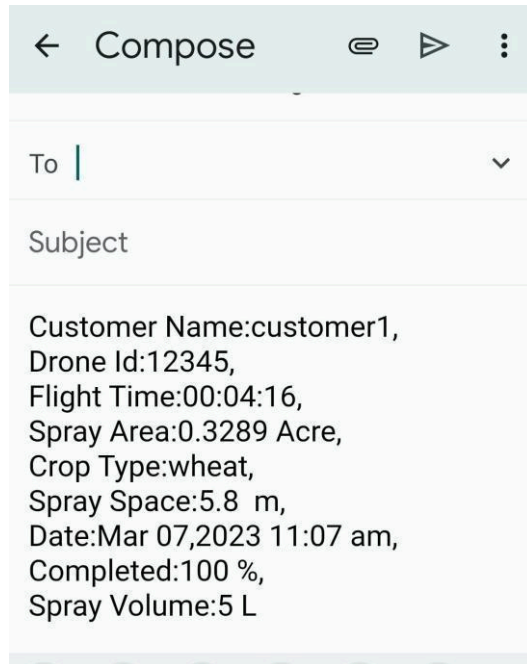

Figure 28 : Shared report sent through email.

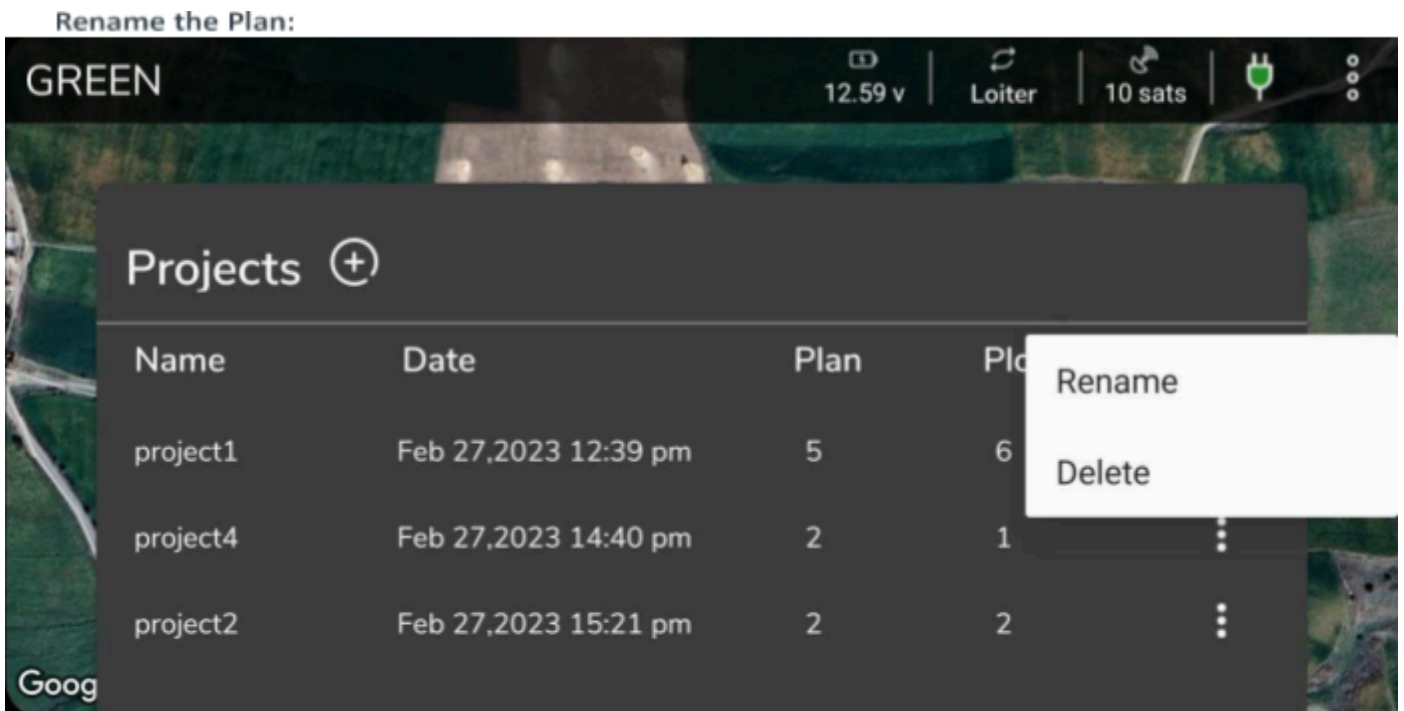

Figure 29 : Rename a plan

Select the plan and click on the three dots available on the right-hand side of the name plan in the list. Select Rename option from the pop-up message to rename as shown in the above image.

<h1>Flight Manual</h1>			
<h2>Pavaman Aviations Private Limited</h2>			
Issue No.	09	Version No.	1.9
Date	22/07/2024	Document Reference	PA - 8

Now, AeroGCS GREEN allows the user to 'Edit Plot' or 'Edit plan'. Click on the 'Edit Plot' button to edit the plot otherwise, you can move further with the same plan and plot. Using the same plan and plot will reduce the time taken. 'Create Plan' using the plot and adjust the parameters if required. Save the changes made and load the plan to have a smooth flight. For creating a new project follow the page "Create a New Project" from the same user manual.

Projects

A Project here is nothing but a collection of plans and plots with proper settings of parameters that are required to have a smooth and safe flight.

The following are the operations performed with a project:

1. Create a Project
2. Open an existing project
3. Edit project
4. Save project

The creation of a new project is possible from the dashboard. Click on  it from the dashboard. Then click on

3.1.5. Create a New Project

 it to create a new project.

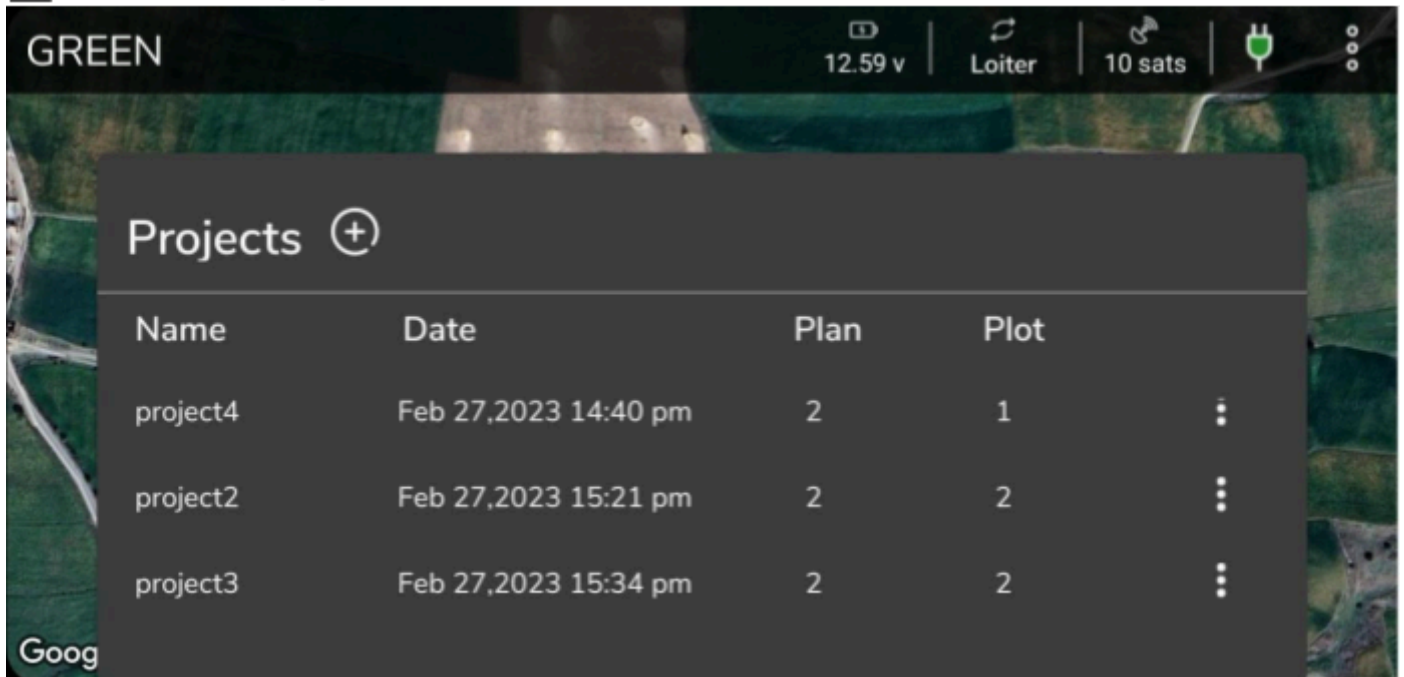

Figure 30 : Create a Project from dashboard

Flight Manual			
Pavaman Aviations Private Limited			
Issue No.	09	Version No.	1.9
Date	22/07/2024	Document Reference	PA - 8

3.1.6. Select a Flying Method

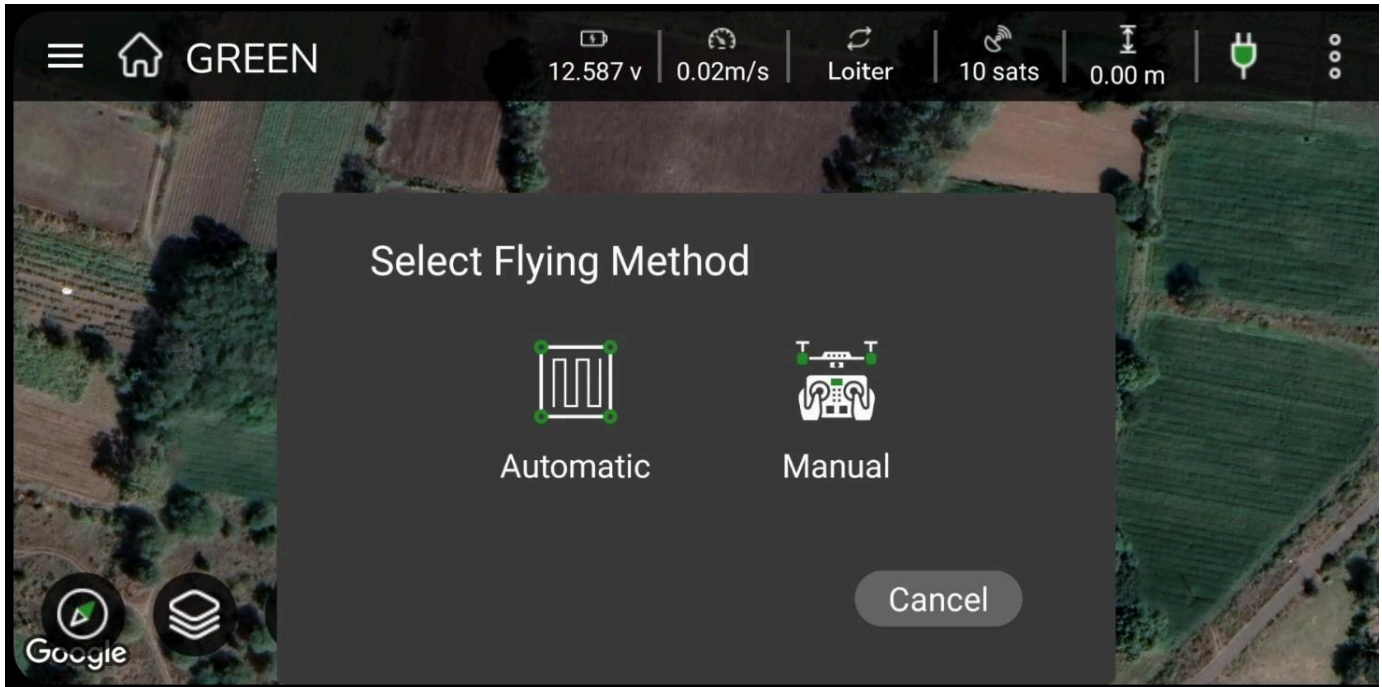

Figure 31 : Select a Flying Method

For creating a plot, firstly select a flying method from the options provided.

Automatic: By using this method, the user can plot a field plot on Google Maps.

Manual: By using this method, the user can plot the field plot on the field actually by using RC/Mobile or drone. Arm the drone for marking accurate positions on the field. Disarm the motors after marking the exact area.

1. Automatic Flying Method:

Select this method to mark the area on the field for spraying. It will now allow the user to select any one option from the supported options as shown in the following image.

Flight Manual			
Pavaman Aviations Private Limited			
Issue No.	09	Version No.	1.9
Date	22/07/2024	Document Reference	PA - 8

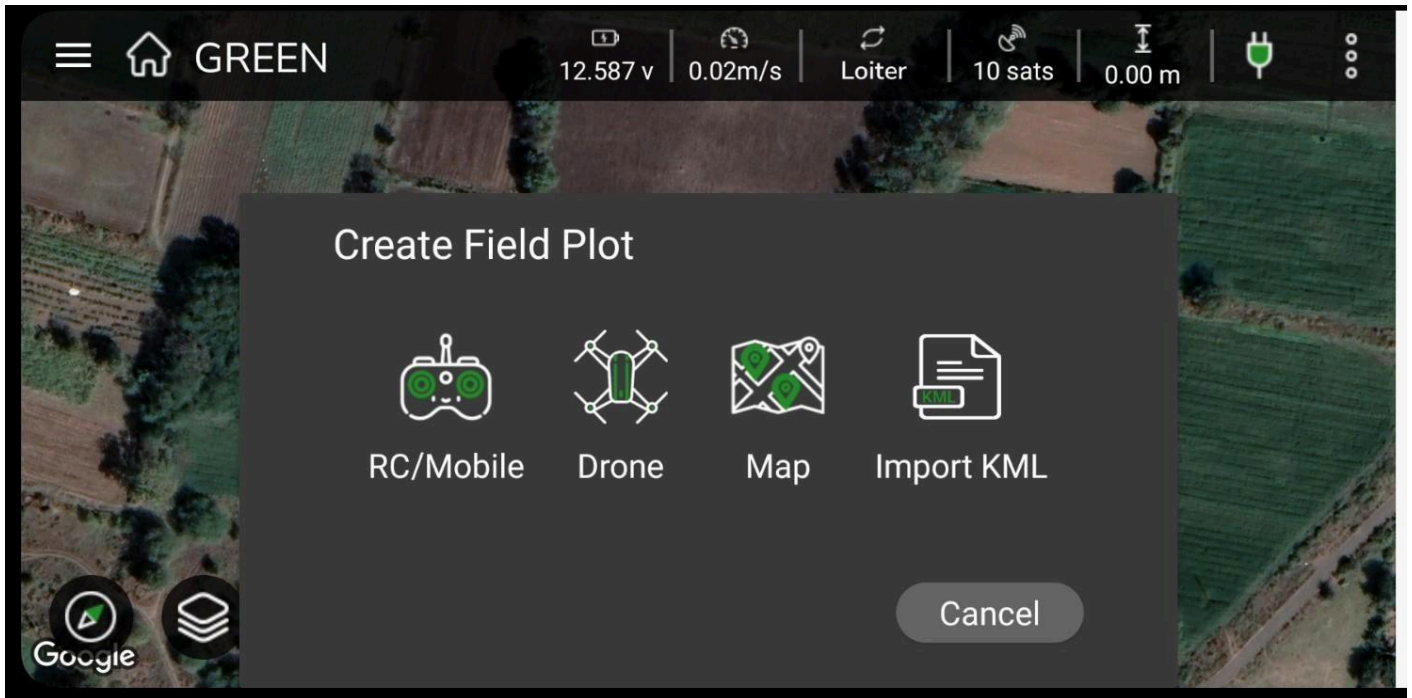

Figure 32 : Create Field plot

2. Create a Plot:

Firstly, click on "Start Here" button popped on the screen. Then Start with "Field Plot" or "Mission Plot"

"Now, AeroGCS GREEN will require the options to create a field plot using. It offers 4 options such as:

3. RC/ Mobile

Carry RC or Mobile to the actual field. Mark the boundary points by physically moving to the specific location. Mark the entire field plot by walking and reaching the exact locations. Save that plot and use it for flying the drone. The accuracy of the plotting area will be improved with this method.

4. Drone

In a similar way, as the boundaries of the field plot are marked with RC/Mobile, mark the boundary with the help of a drone flying in the air.

5. Map

Use the location on Google Maps to create a field plot using the map functionality. It offers various features like 'Add point', 'Clear', and 'Save' options. The pointer and the background moving on the Google Maps screen give precise field plotting.

Flight Manual			
Pavaman Aviations Private Limited			
Issue No.	09	Version No.	1.9
Date	22/07/2024	Document Reference	PA - 8

6. Import KML

The user can import KML files for plotting a field plot which is available at different locations. After selecting a proper option, move further by adding points to the plot by using the 'Add Point' option. Navigate on the map to mark the points. When you are done with marking all the points then 'Save' the plot.

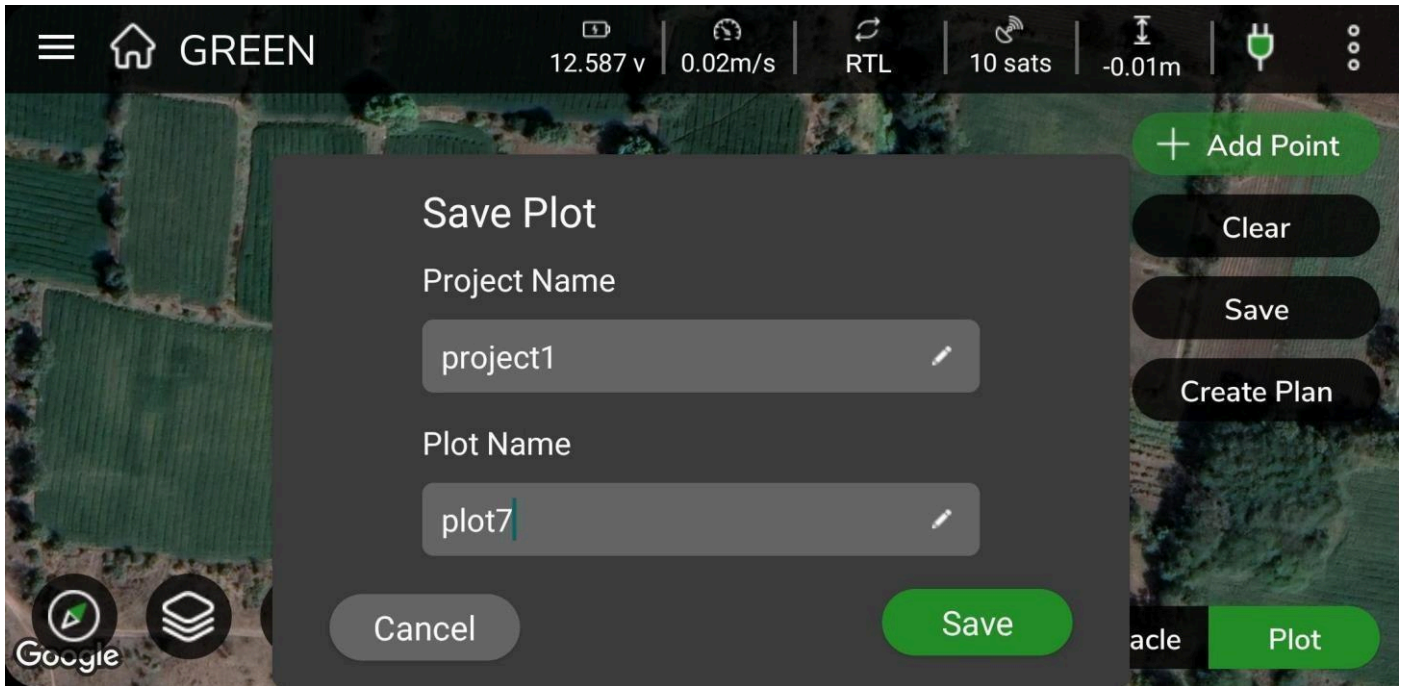

Figure 31 : Save Plot

- **Create Plan**

Now, create a plan by selecting the 'Create Plan' button. The spraying map will be displayed on the screen with the parameter setting options window as shown in the following image.



Figure 32 : Create a Plan

Flight Manual			
Pavaman Aviations Private Limited			
Issue No.	09	Version No.	1.9
Date	22/07/2024	Document Reference	PA - 8

All the dimensions including lengths of the plan are displayed on the screen which includes the calculation of the area in Acres as shown in the above image.

The list of parameters that are to be changed is displayed on the left-hand side of the screen as shown in the image. The slide bars are provided through which the user can adjust these values.

The plan created has a fence marked outside of the plan indicated by a red line as shown in the image. This fence can be adjusted according to the requirements of the application.



Figure 33 : Fence Boundary Adjustments

These fence boundaries are intended to try and prevent your vehicle from flying into (exclusion) or out of (inclusion) the fences by triggering a failsafe action like RTL or, if flying in Loiter mode for a Copter and Object Avoidance is set up, the vehicle will typically stop before breaching the fence and, in some cases, plan paths around the boundaries.

Save all the changes made and move to flight with the "Load" option.

Flight Manual			
Pavaman Aviations Private Limited			
Issue No.	09	Version No.	1.9
Date	22/07/2024	Document Reference	PA - 8

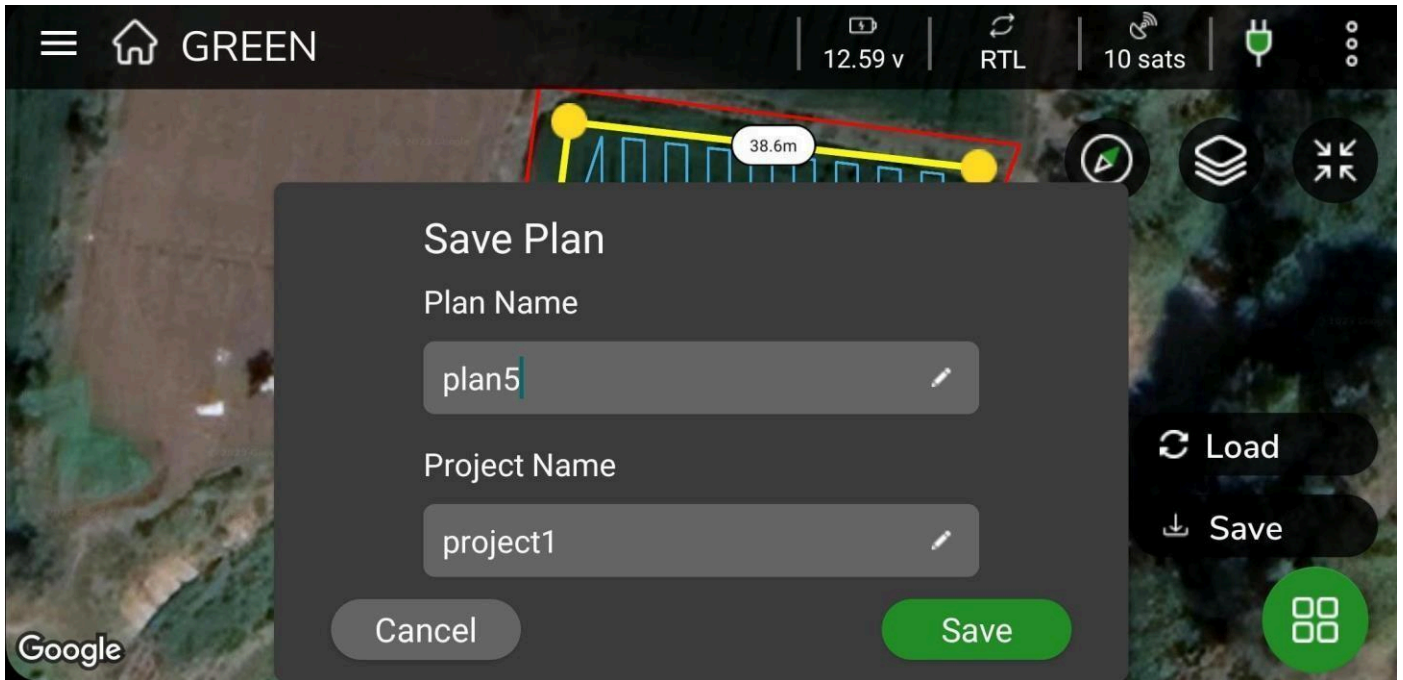

Figure 34 : Save Plan

Save the plan with the suitable plan name in the respective project. The plan will be saved in the respective project which can be accessed by the user whenever is required.

1. Manual Flying Method

AeroGCS GREEN allows the user to fly a drone manually that will be controlled by RC. The track of manual flight can be observed on the screen.

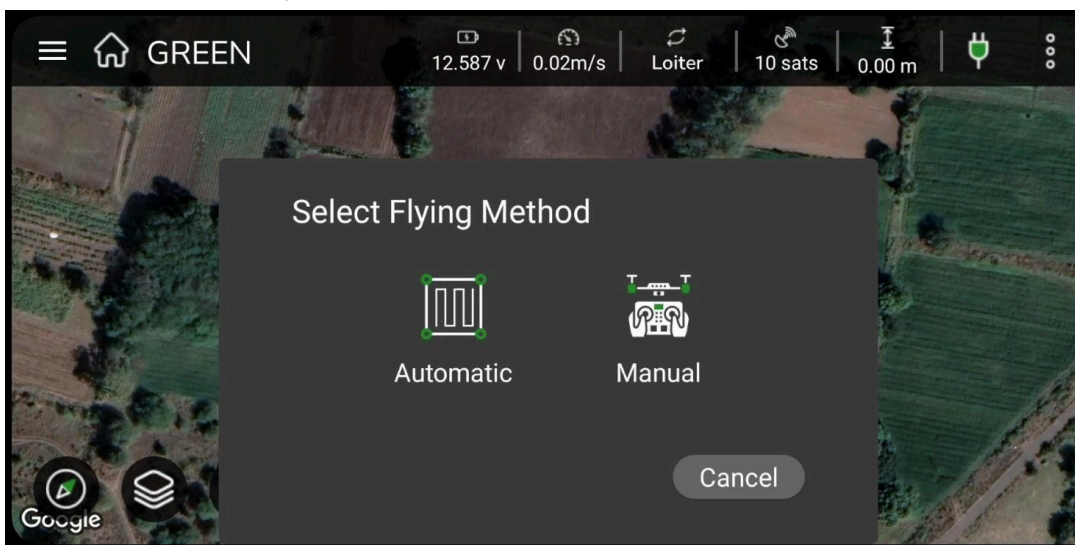

Figure 34 : Selection of Flight Type

Flight Manual			
Pavaman Aviations Private Limited			
Issue No.	09	Version No.	1.9
Date	22/07/2024	Document Reference	PA - 8

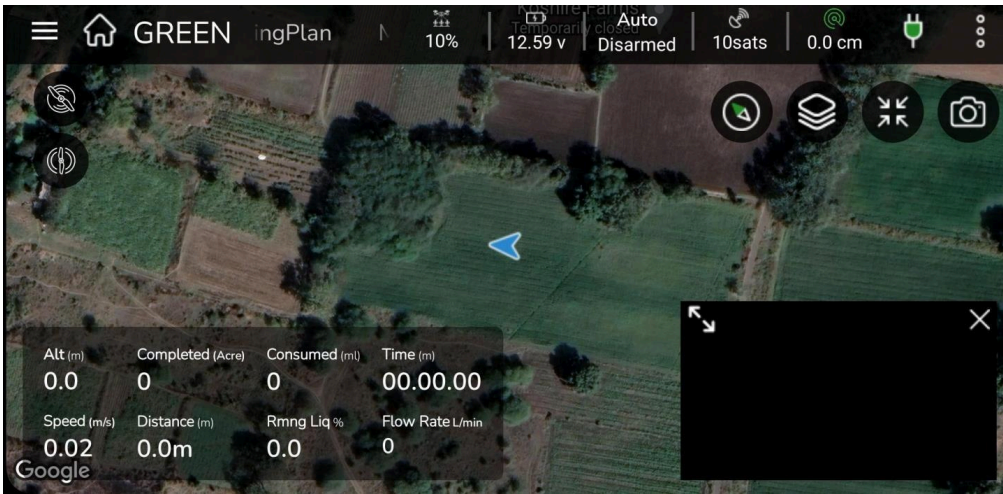



Figure 35 : Manual Flight

Click on the "Arm"  command to arm the motors and start the flight. This will be indicated with "Arming Motors" message on the screen as shown in the following image.

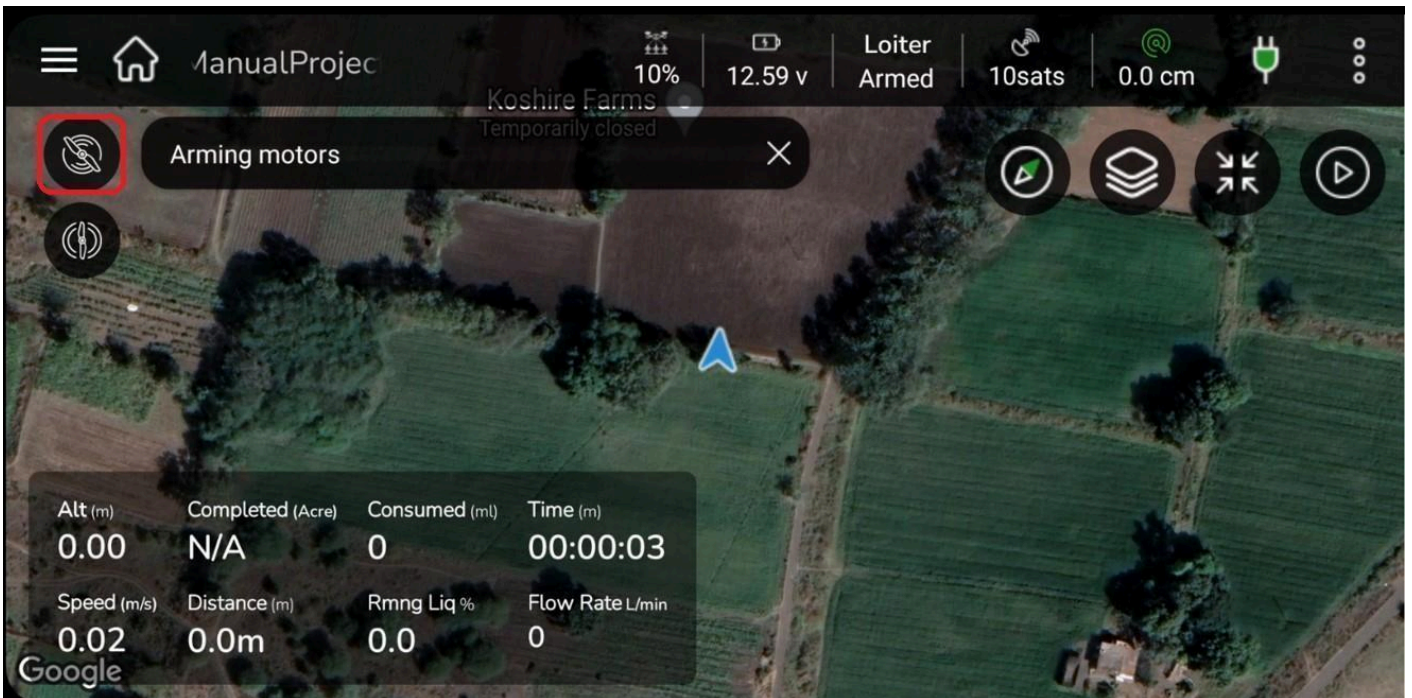

Figure 36:Arming Motors of Manual Flight

The manual flight will be controlled through RC on the field. Give the commands through RC for monitoring the flight. The manual flight can be traced from the flyview of AeroGCS GREEN as shown in the following image.

<h1>Flight Manual</h1>			
<h2>Pavaman Aviations Private Limited</h2>			
Issue No.	09	Version No.	1.9
Date	22/07/2024	Document Reference	PA - 8

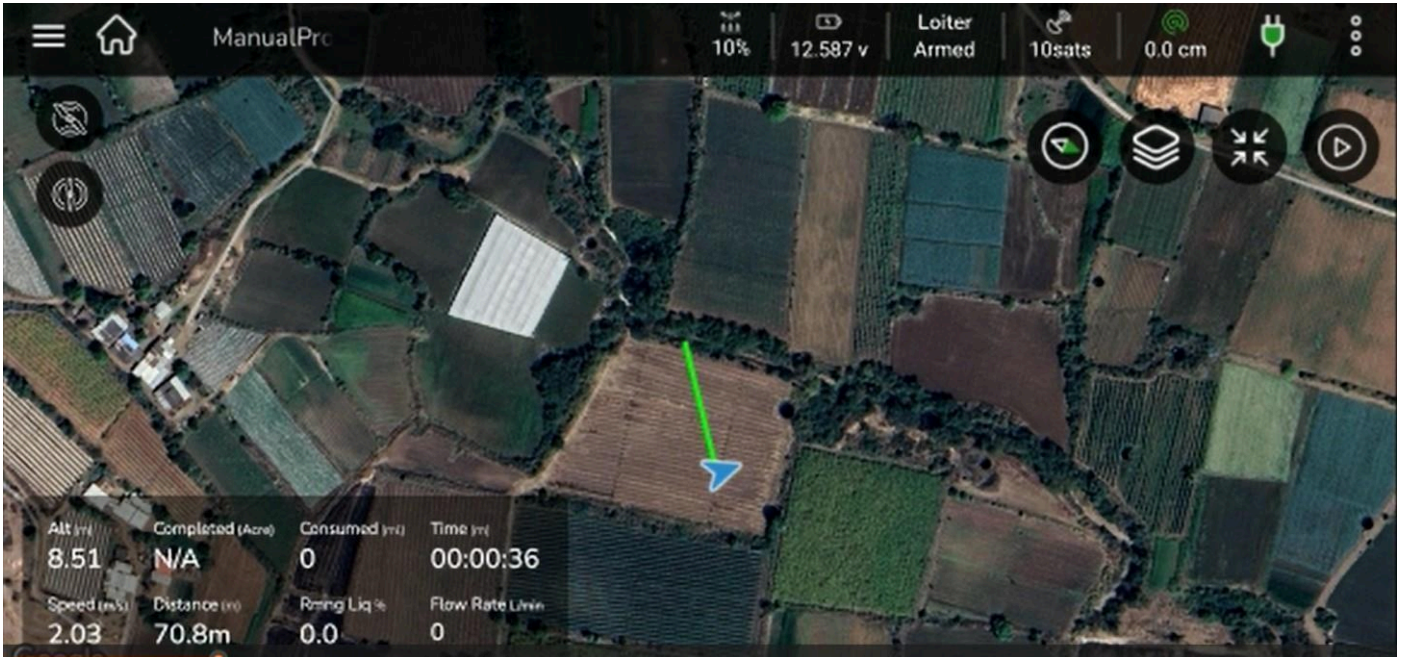

Figure 37 : Manual Flight Started

The field report will be generated after completing the manual flight which can be synchronized with AeroMegh Account.

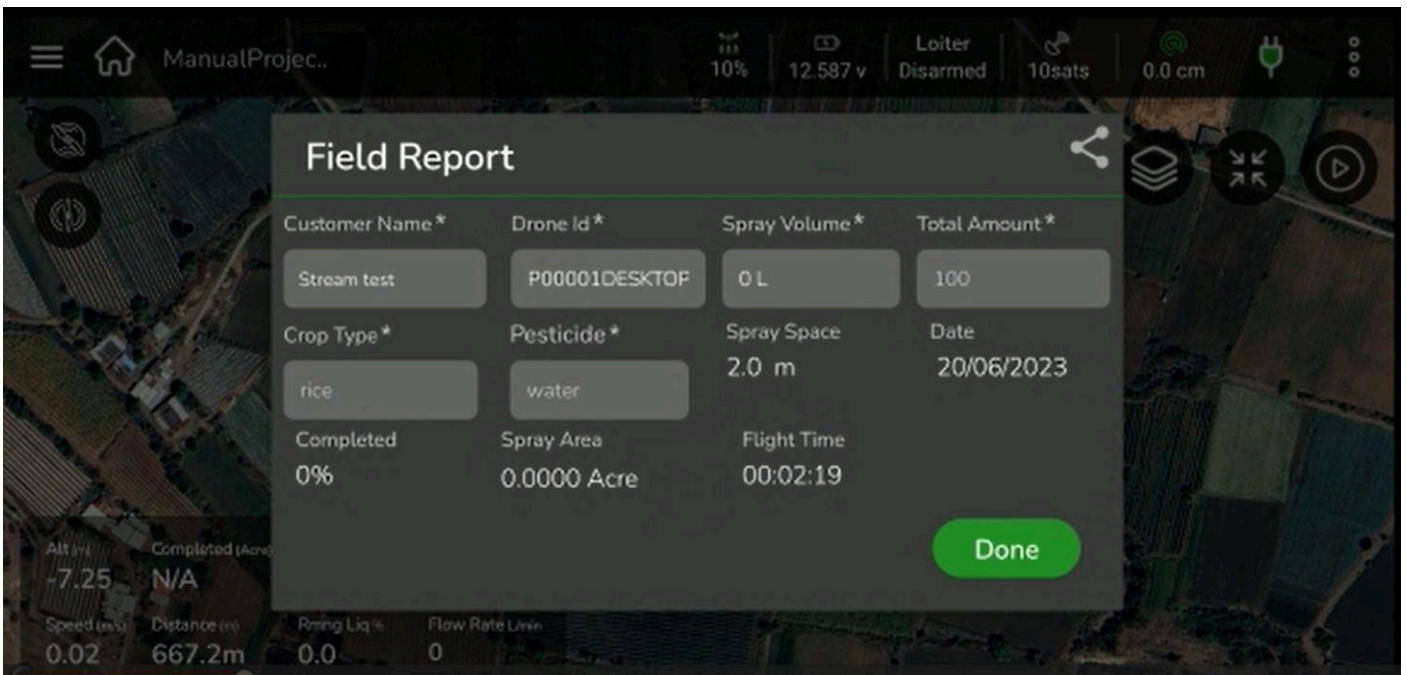

Figure 38 : Field Report of a Manual Flight

<h1>Flight Manual</h1>			
<h2>Pavaman Aviations Private Limited</h2>			
Issue No.	09	Version No.	1.9
Date	22/07/2024	Document Reference	PA - 8

Handling Existing Project

To save time and effort AeroGCS GREEN allows the user to use existing projects.

Open a Project

Project is a collection of different plans and plots. All the plans and plots are stored in a project. Whenever the project is selected, the list of plans or plots will be displayed on the screen.

From Home Menu:

Go to the "Home menu" to open existing projects. Select and click on a project to open from a list displayed on the screen as shown.

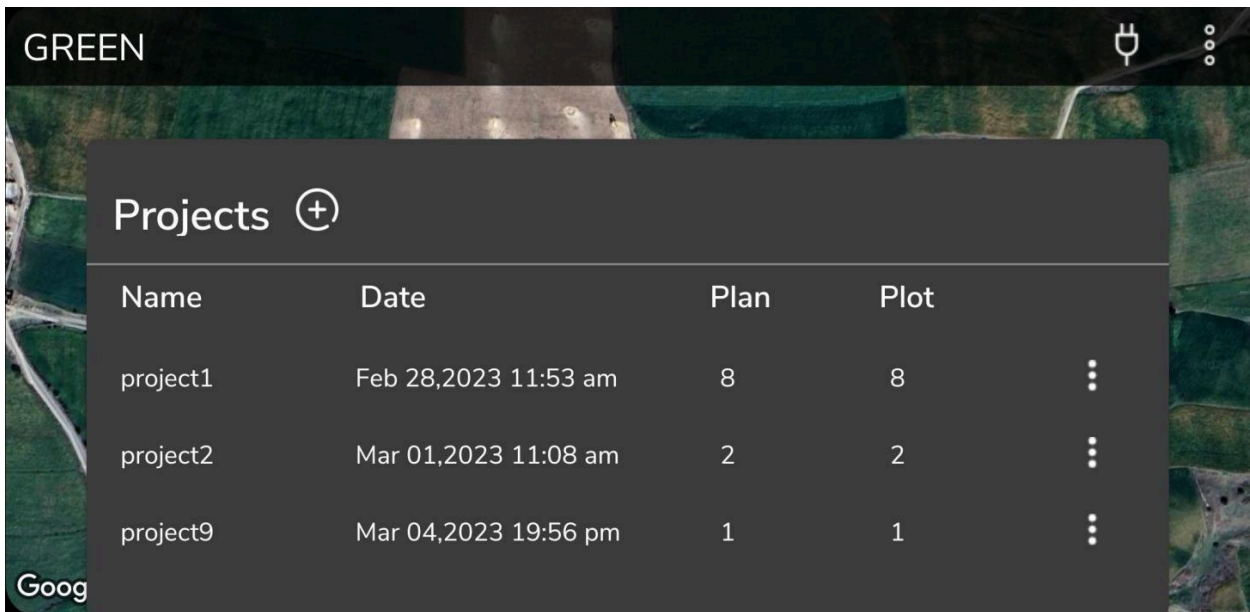

Figure 39 : Open a Project

Select a project to open. The list of plans or plots will be displayed.

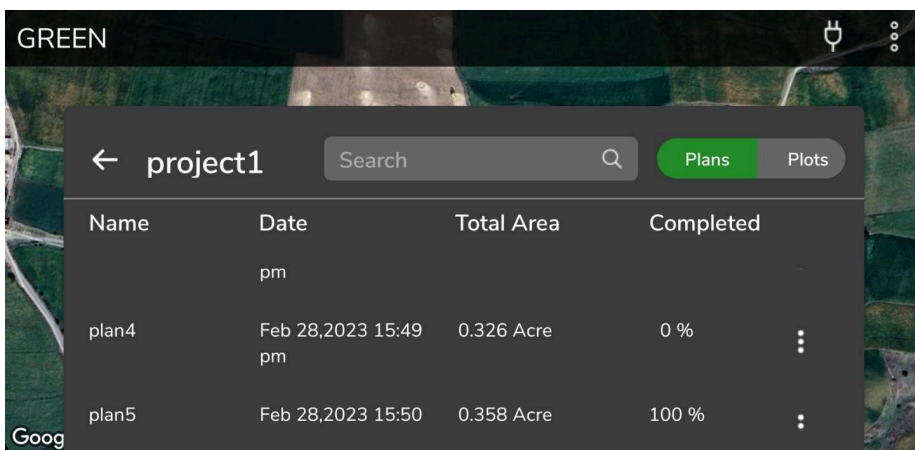

Figure 40 : Open a plan or Plot from Project

<h1>Flight Manual</h1>			
<h2>Pavaman Aviations Private Limited</h2>			
Issue No.	09	Version No.	1.9
Date	22/07/2024	Document Reference	PA - 8

There are multiple plans and plots available in a project. Use the toggle button to select either "Plan" or "Plot".

Accordingly, the list of plans or plots will be displayed. If the user wants to search a particular plan or plot "Search" facility is provided as shown in the image.

Click on the plan name or plot name to open.



Figure 41 : Existing plan is opened.

The user can edit the projects in other ways as shown in the image. Select  from the dashboard.

This action will display the list of projects available.



Figure 42 : Open a Project from Dashboard

<h1>Flight Manual</h1>			
<h2>Pavaman Aviations Private Limited</h2>			
Issue No.	09	Version No.	1.9
Date	22/07/2024	Document Reference	PA - 8

Select the desired project. It will display the list of plans and plots present in each project. Use the toggle button to select plans or plots. The list of plans plots is displayed as shown in the images below:

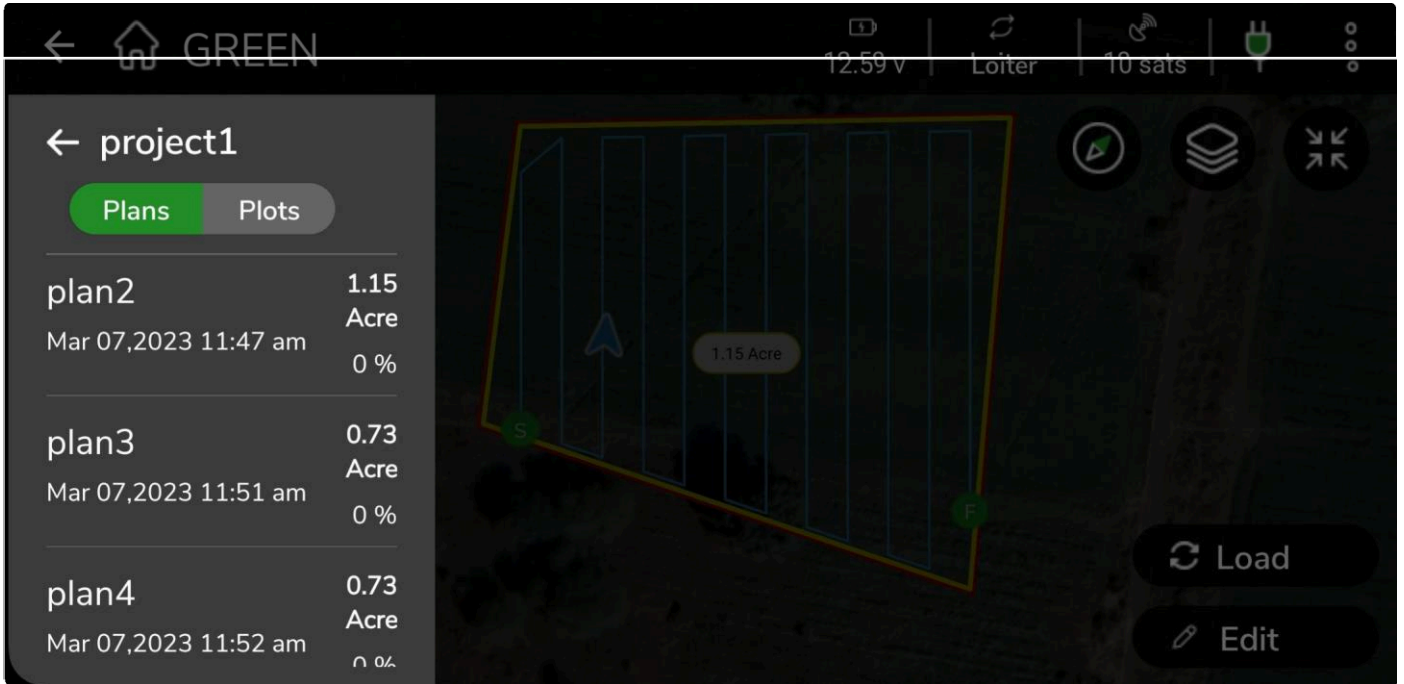

Figure 42 : Open a Plan from Dashboard

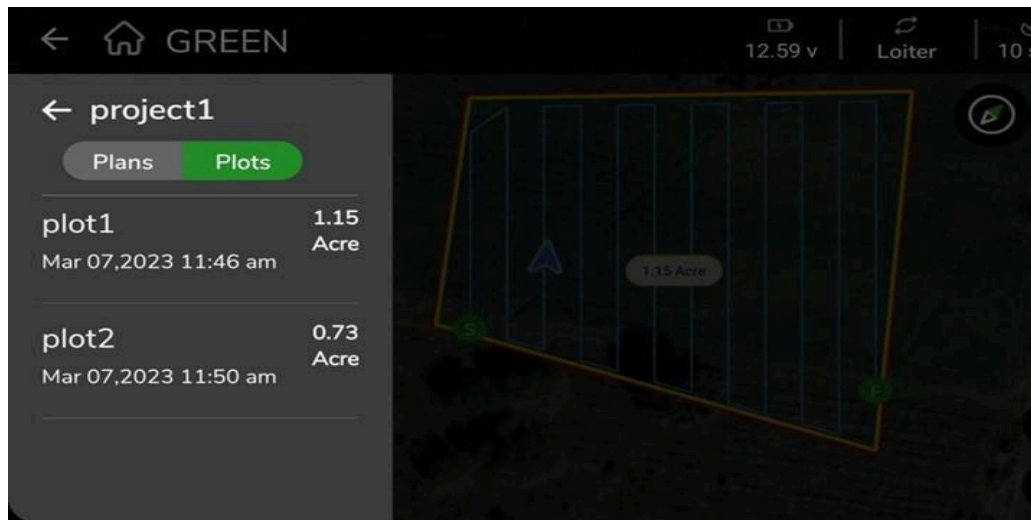

Figure 43 : Open a Plot

Edit a Plan:

Click on the "Edit" button to edit the parameters if required. The existing plan will be opened as shown in the image. Select an 'Edit' button to edit the parameters.

Flight Manual			
Pavaman Aviations Private Limited			
Issue No.	09	Version No.	1.9
Date	22/07/2024	Document Reference	PA - 8



Figure 44 : Existing Plan

Now the list of parameters is displayed on the left-hand side of the screen. The modifications in the parameters are done by using the slide bars. The following parameters can be altered by using respective slide bars.

Spray Rate: The rate of spraying can be adjusted from 10% to 100% by using the slide bar.

Spray Altitude: The altitude of spraying can be adjusted from 1 meter to 20 meters.

Flight Speed: The flight speed can be adjusted from 1 m/s to 10 m/s.

Fence Boundary: Adjust the fence boundary from 2 meters to 10 meters.

All these altered parameters can be saved into the existing plan or the user can save these by creating new plan.

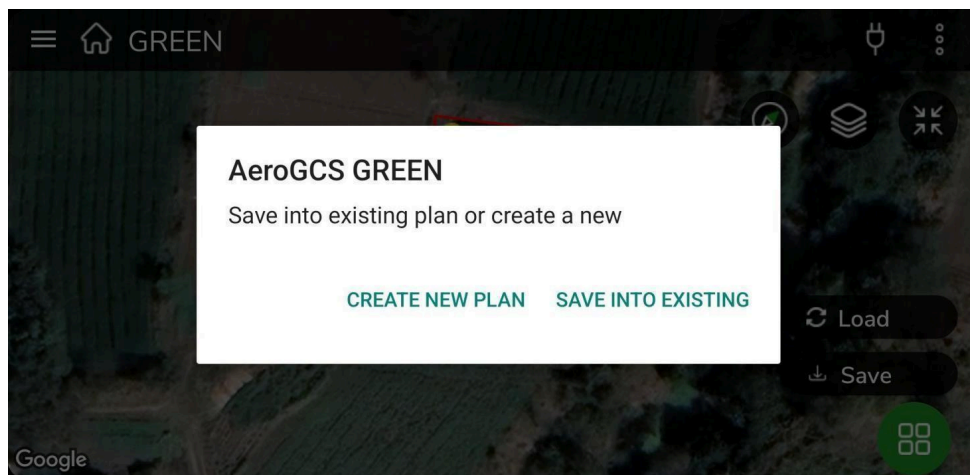



Figure 45 : Save an Edited Plan

Flight Manual			
Pavaman Aviations Private Limited			
Issue No.	09	Version No.	1.9
Date	22/07/2024	Document Reference	PA - 8

If the flight is not completed and has a resume point marked it will be ignored if the user tries to edit the parameters. By using the slide bars for different parameters on the left-hand side, the user will be able to change the parameter if required.

 this icon can be used to adjust the settings of parameters, route adjustments, etc.

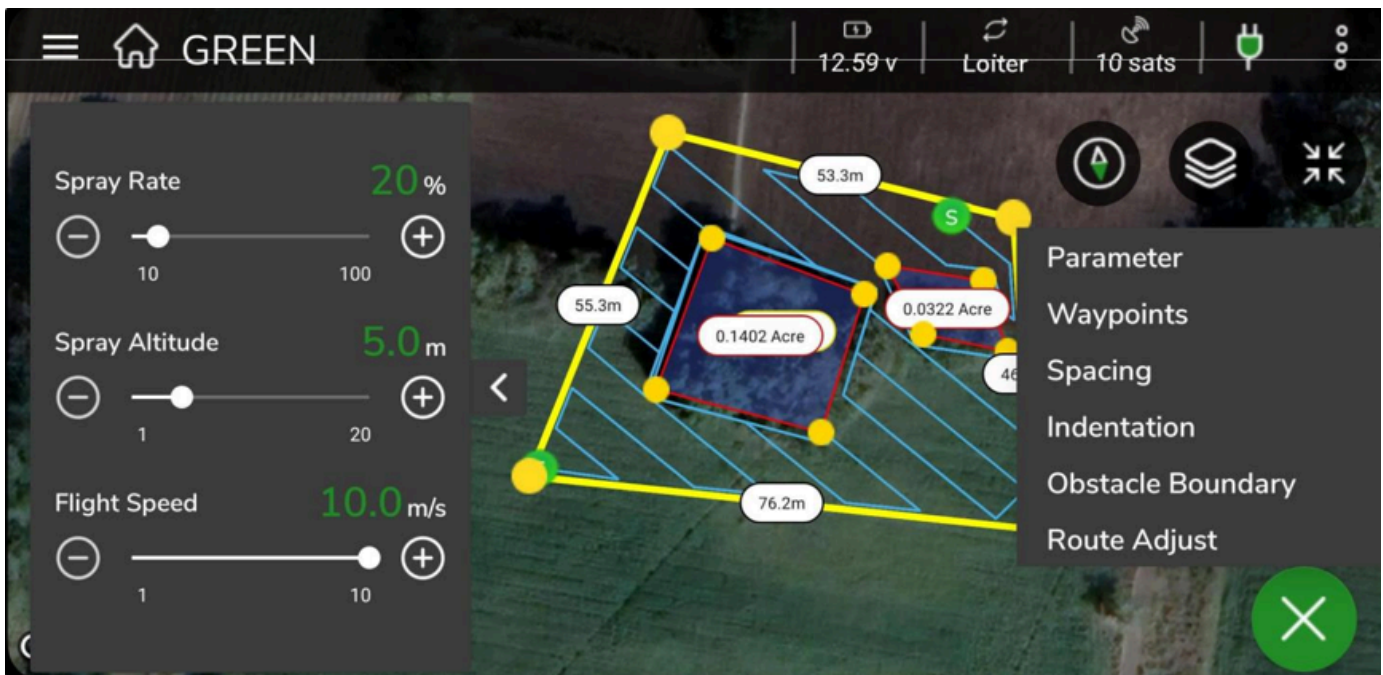

Figure 46 : Adjusting Parameters

This option provides a setting of following:

1. Parameter
2. Waypoints
3. Spacing
4. Indentation
5. Obstacle Boundary
6. Route Adjust

Details of the above points are discussed in the "Mission Planning Functionality" section of the same user manual. Save the changes to the existing plan and click on the "Load" button to fly the drone.

Observe the flight with the adjusted parameters. Complete the mission plan and get the report generated for the respective flight.

Recent changes made in the plan and plot will be saved and displayed in the list.

Flight Manual			
Pavaman Aviations Private Limited			
Issue No.	09	Version No.	1.9
Date	22/07/2024	Document Reference	PA - 8

Edit a Plot:

Like the plan editing facility, the user can edit a plot stored in the project.

This functionality provides the editing of a plot on the map. The user can select a specific plot from the list and then move on with editing a plot.



Figure 47 : Edit a Plot

Click on the "Edit Plot" button to edit the plot.

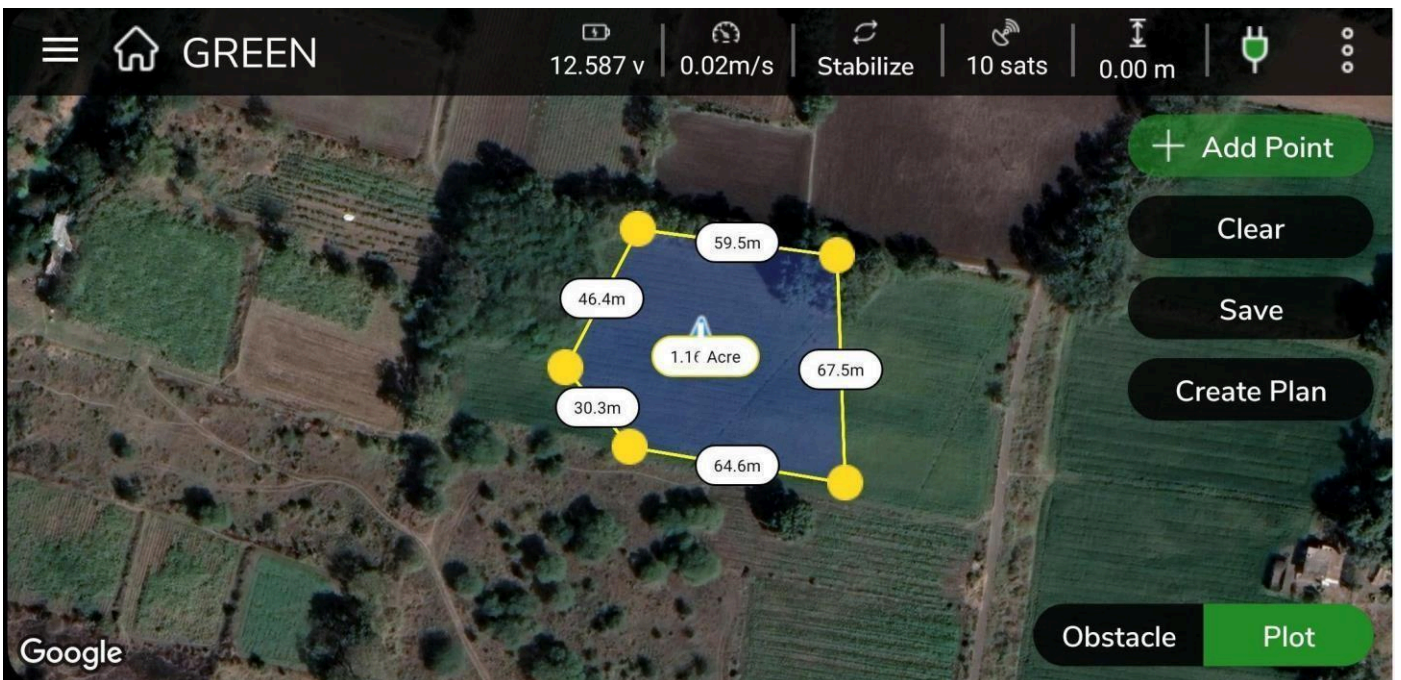

Figure 48 : Edit a Plot on Map

Flight Manual			
Pavaman Aviations Private Limited			
Issue No.	09	Version No.	1.9
Date	22/07/2024	Document Reference	PA - 8

Now, the user has several options to modify if required such as:

Add Point: The user may add a few more waypoints to the existing plot.

Clear: Delete the earlier points and obstacles by prompting the message on the screen. If all the points are to be deleted, then click on "Yes" if you want to delete all the points otherwise select "No" button.

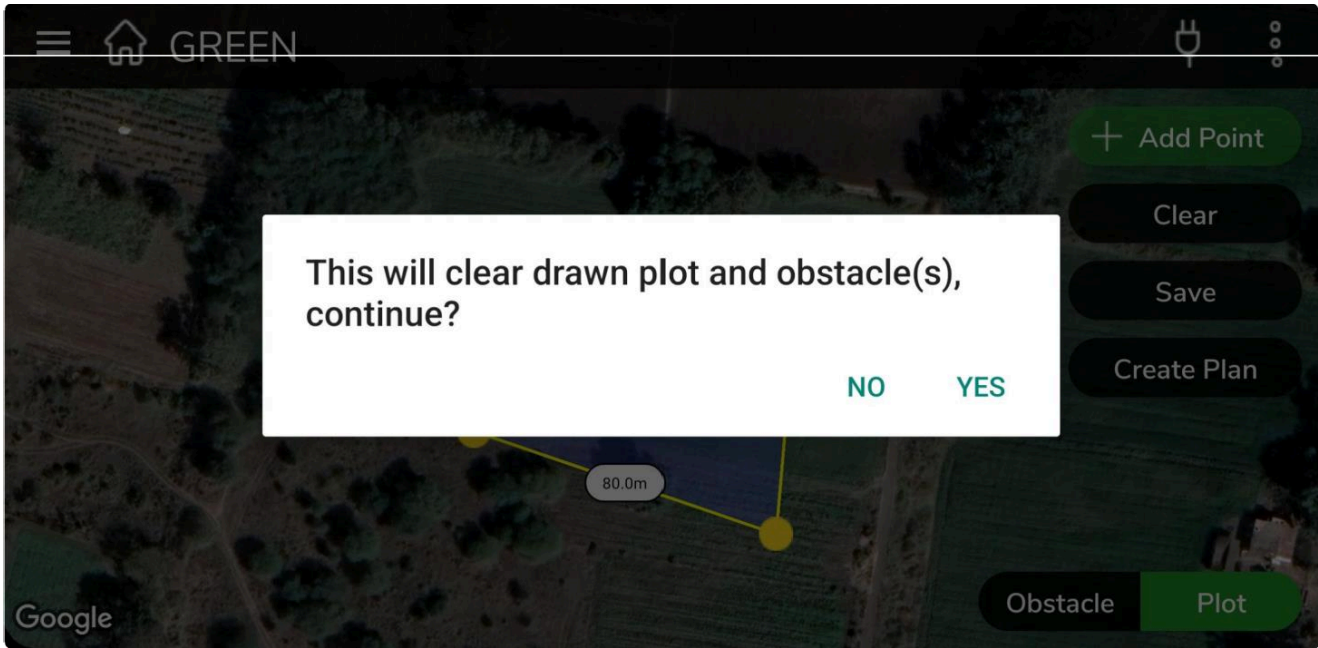

Figure 49 : Clear the points from a plot

<h1>Flight Manual</h1>			
<h2>Pavaman Aviations Private Limited</h2>			
Issue No.	09	Version No.	1.9
Date	22/07/2024	Document Reference	PA - 8

Save: Save all the changes by clicking the "Save" button. While saving a plot it will ask whether to "Create new Plot" or "Save into Existing Plot".

Create Plan: This button will create a plan on a plot. Now the user may be able to modify the parameters, spacing, indentation, etc. if required. Save all the changes by selecting "Save" button.



Figure 50 : Create a Plan

Obstacle: This option will allow the user to mark the obstacles on the given plot if any. Follow the instructions that appear on the screen. After marking an obstacle plot save the plot with "Save Obs" button as shown in the image below:

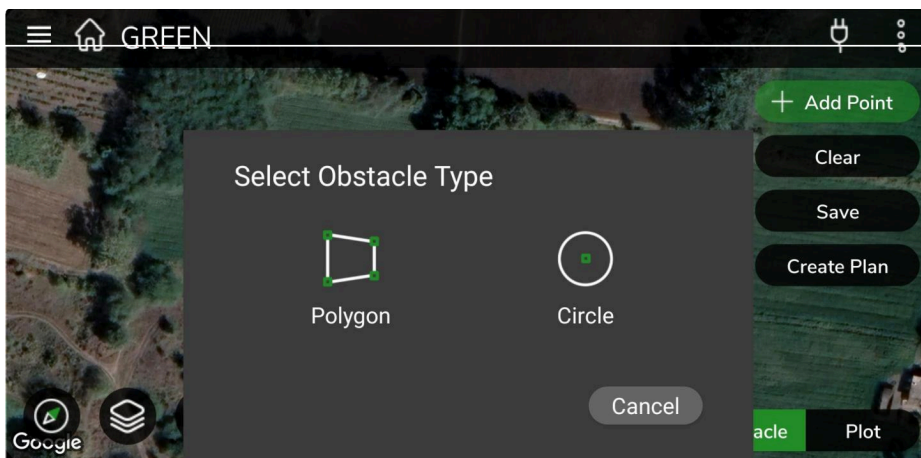

Figure 51 : Select Obstacle Type

Flight Manual			
Pavaman Aviations Private Limited			
Issue No.	09	Version No.	1.9
Date	22/07/2024	Document Reference	PA - 8

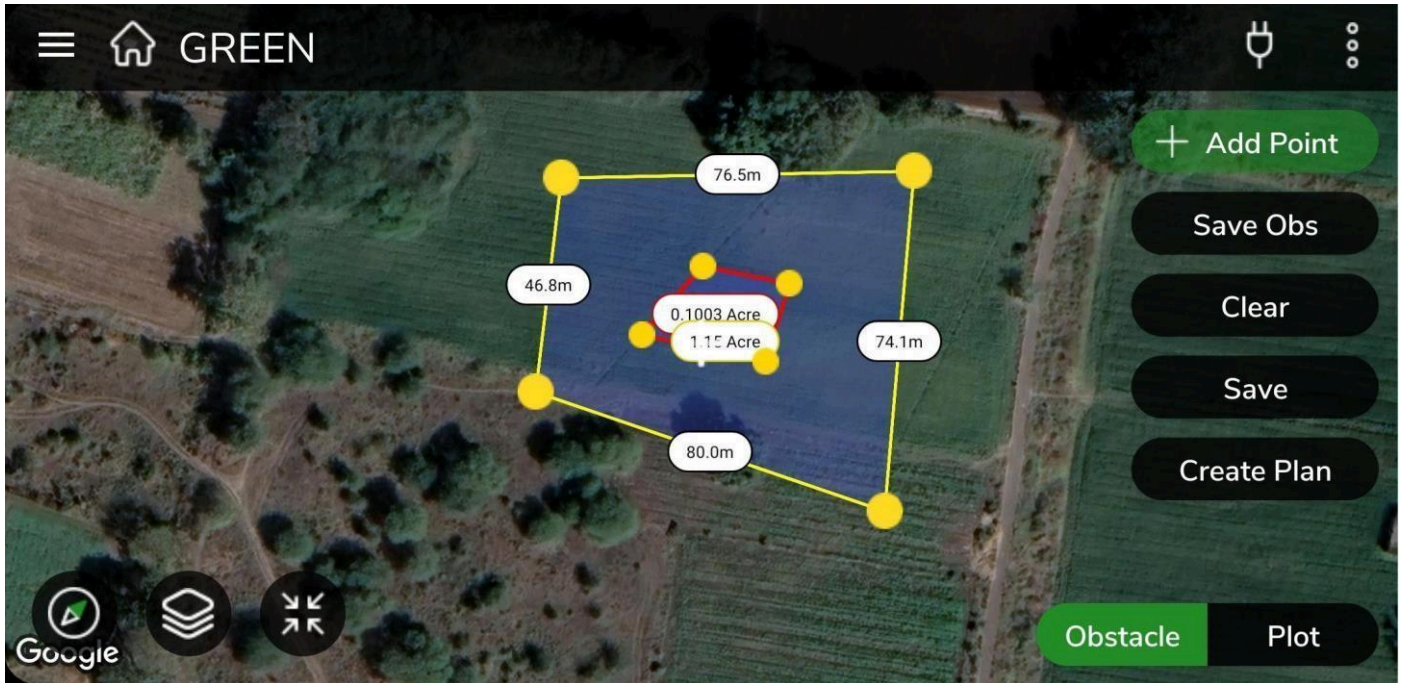

Figure 52 : Obstacle plan added

If obstacle avoidance functionality is to be used, the user can use it here. Add the obstacle plan by selecting obstacle functionality. Save the plot with all these modifications. The user can create a new plot here with the above-mentioned steps.

Rename a Project:

Open the list of projects and select any name of the project which the user wants to rename. Click on three dots. The options of 'Rename' and 'Delete' will be displayed as shown in the following image. Select the 'Rename' option to rename the selected project.

<h1>Flight Manual</h1>			
<h2>Pavaman Aviations Private Limited</h2>			
Issue No.	09	Version No.	1.9
Date	22/07/2024	Document Reference	PA - 8

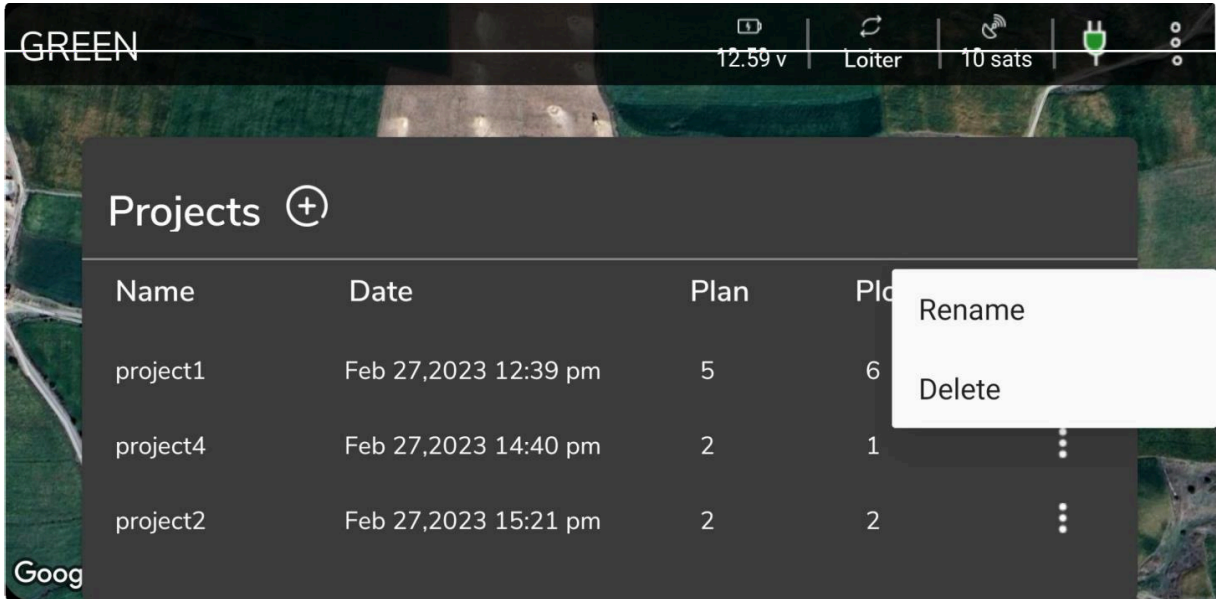

Figure 52 : Rename or Delete Existing Project

The following message will be displayed on the screen to rename the project.
Give a suitable name to the project and press the "Ok" button to proceed.

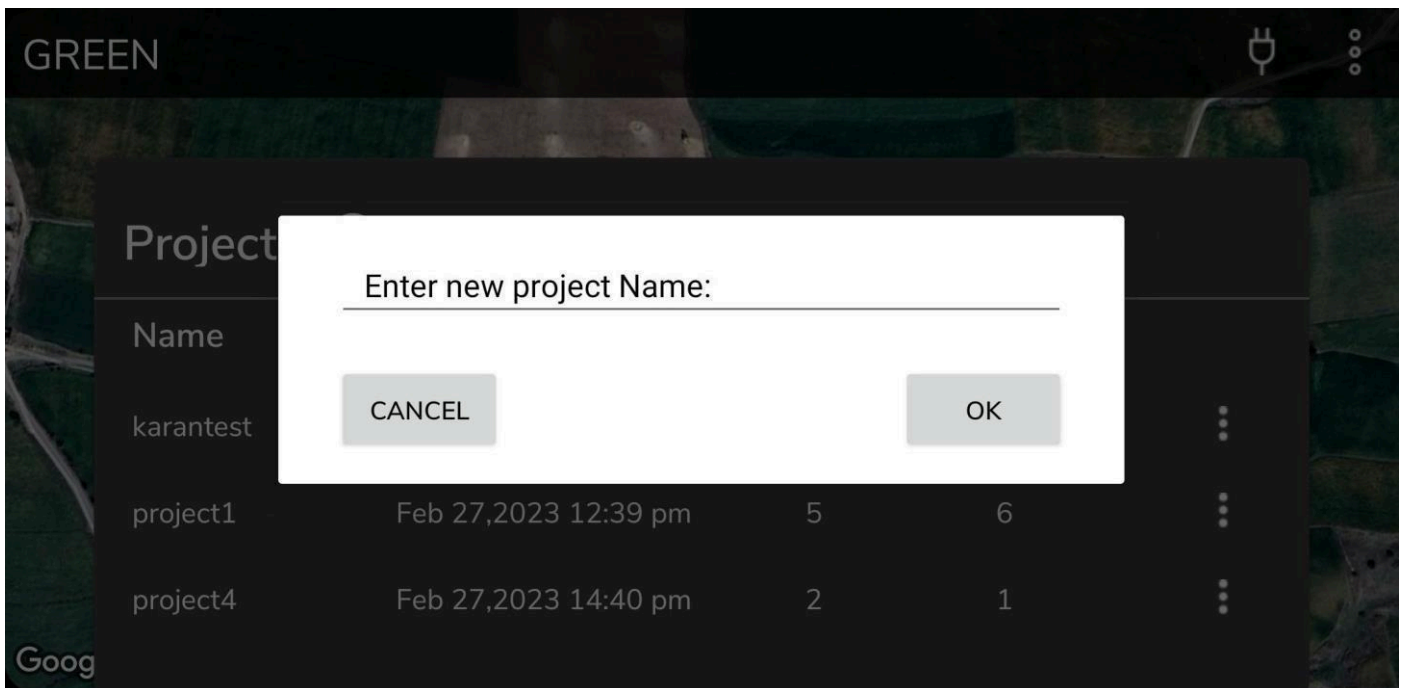

Figure 53 : Rename a Project

Delete a Project:

AeroGCS GREEN allows the user to delete a plan, plot, and project. When a project is deleted all the plans and plots available in that respective project will be deleted collectively and cannot be retrieved afterward. It is possible to delete only a specified plan or plot from a project. Only the specified plan or plot will be deleted.

Flight Manual			
Pavaman Aviations Private Limited			
Issue No.	09	Version No.	1.9
Date	22/07/2024	Document Reference	PA - 8

a) Delete a Plot:

The user can delete a plot by selecting a plot from the list.

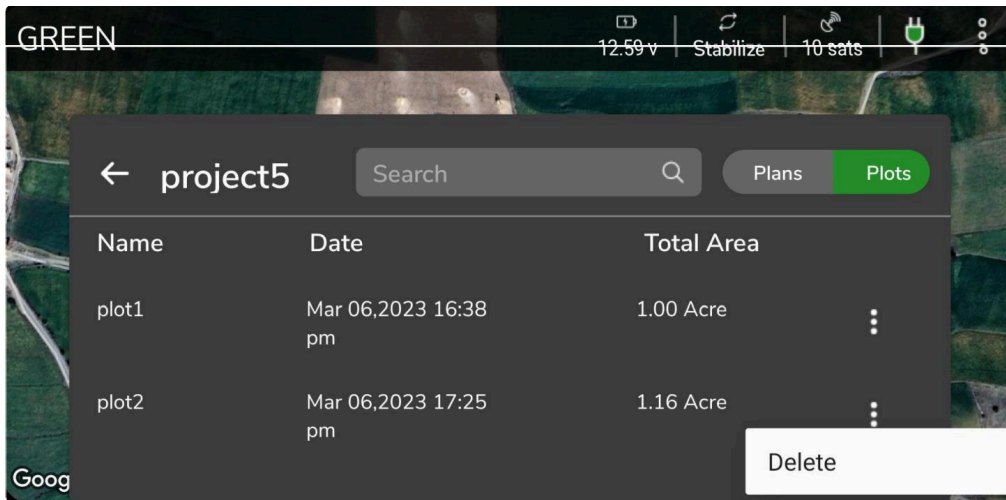

Figure 54 : Delete a Plot

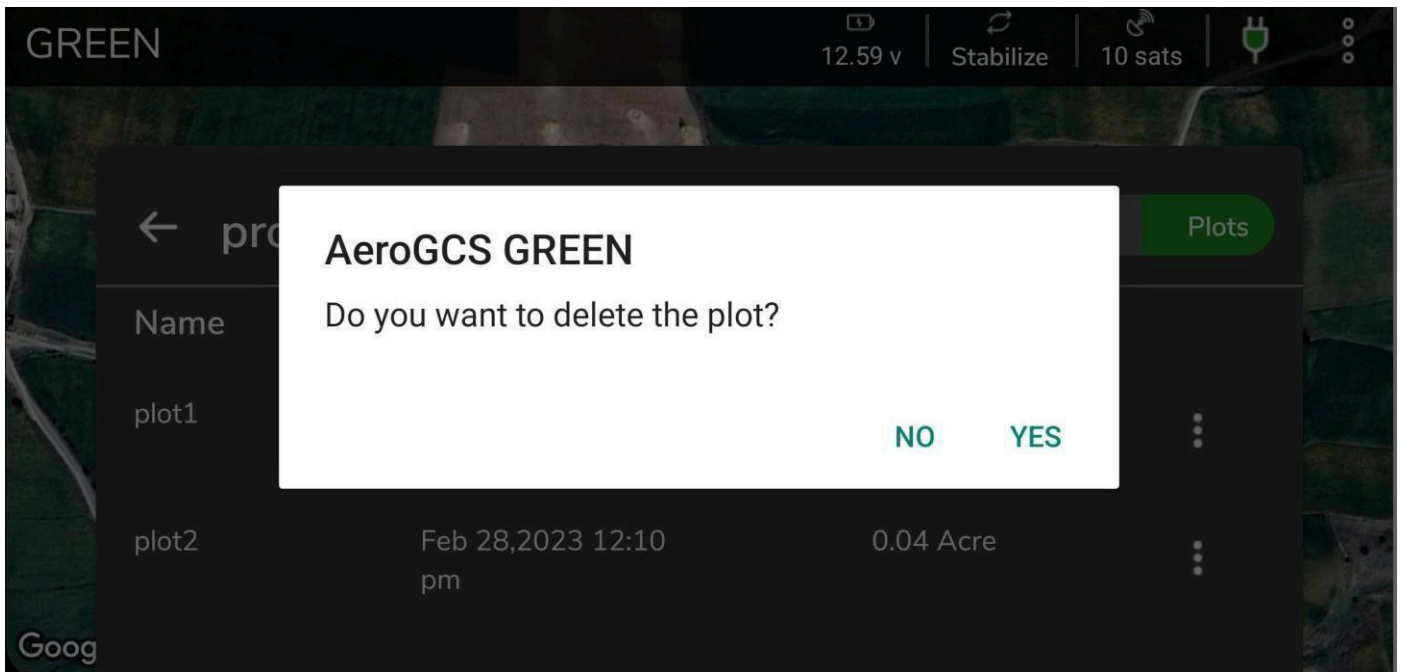

Figure 55 : Confirmation of Deletion of a Plot

b) Delete a Plan:

Any specific plan can be deleted by selecting the name of a plan and clicking on the three dots present on the right-hand side of the name of the plan.

Flight Manual			
Pavaman Aviations Private Limited			
Issue No.	09	Version No.	1.9
Date	22/07/2024	Document Reference	PA - 8

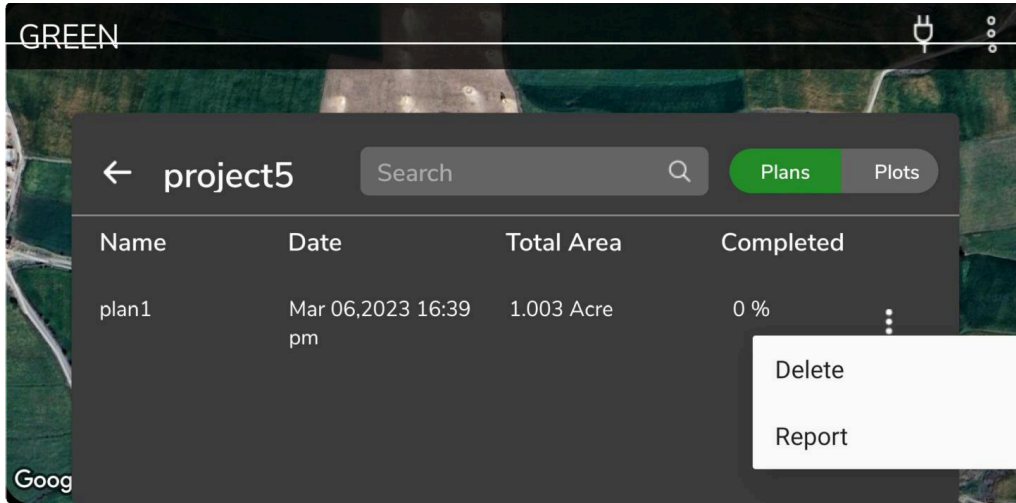

Figure 56 : Delete a Plan

Select "Delete" from two options. The AeroGCS GREEN will display a pop-up message for confirmation of deletion as shown.

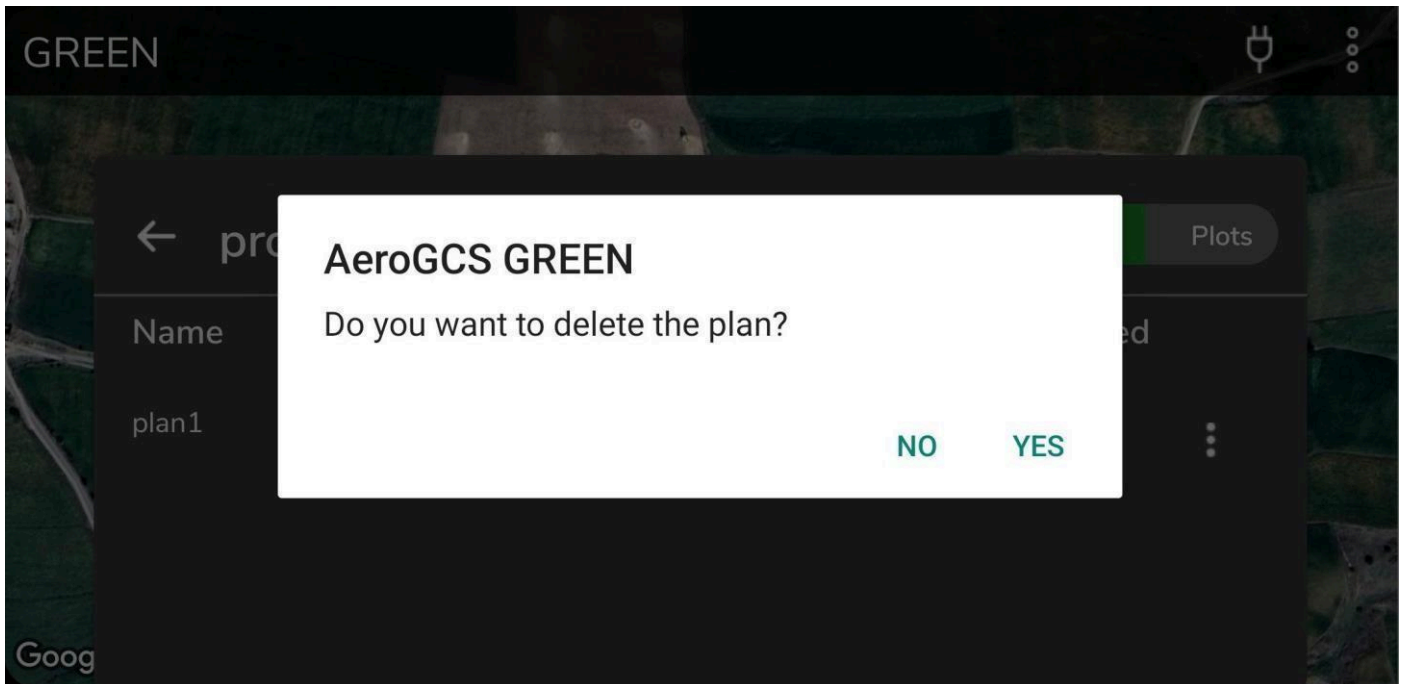

Figure 58 : Delete Plan

c) Delete a Project:

Click on the 'Delete' button to delete the selected project as shown in the above image. All the plans and plots available in the project will be deleted when the user selects to delete a project. The selected project will be deleted permanently therefore confirmation message will be displayed before deletion. Therefore, be careful while deleting the project.

Flight Manual			
Pavaman Aviations Private Limited			
Issue No.	09	Version No.	1.9
Date	22/07/2024	Document Reference	PA - 8

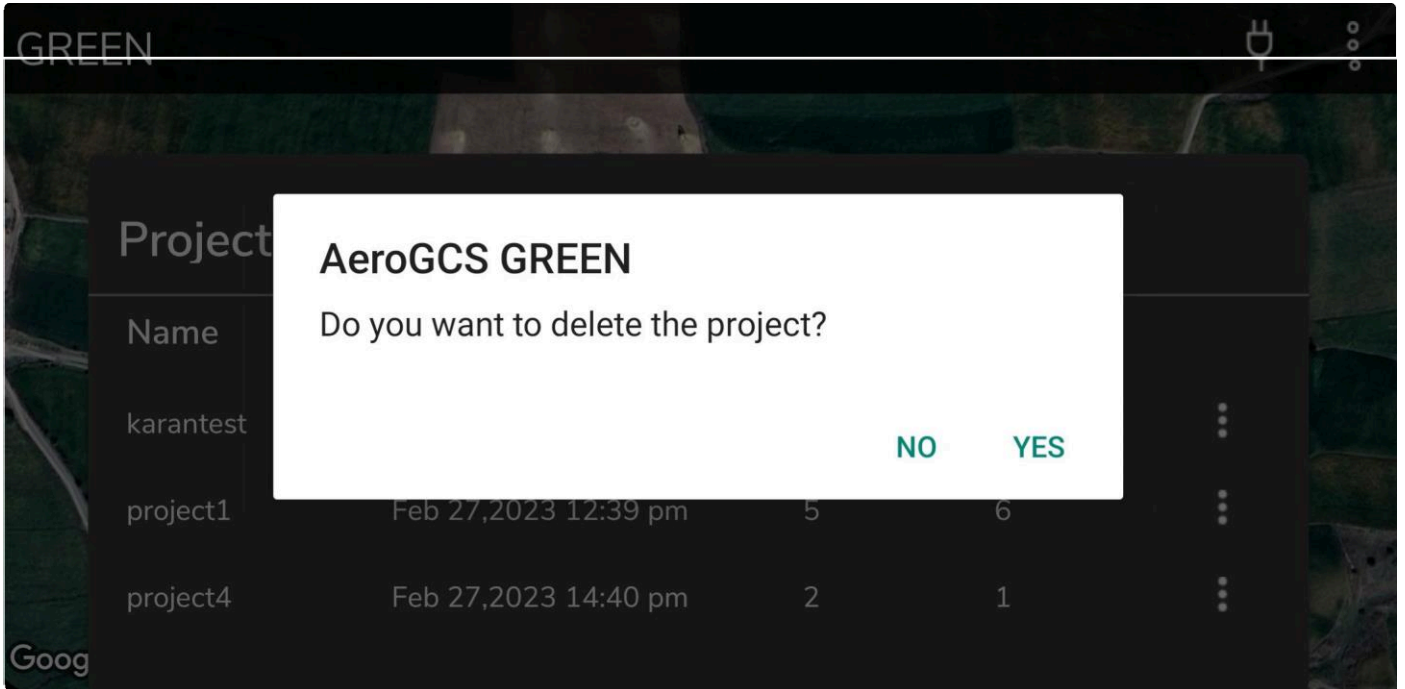

Figure 59 : Delete a Project

4. Connecting a Drone

To have a smooth flight there should be a proper connection between the drone and GCS. All the commands and plans will be followed by the drone in a proper way.

Click on  this icon to establish the connection. It will turn to green color if the proper connection is established.

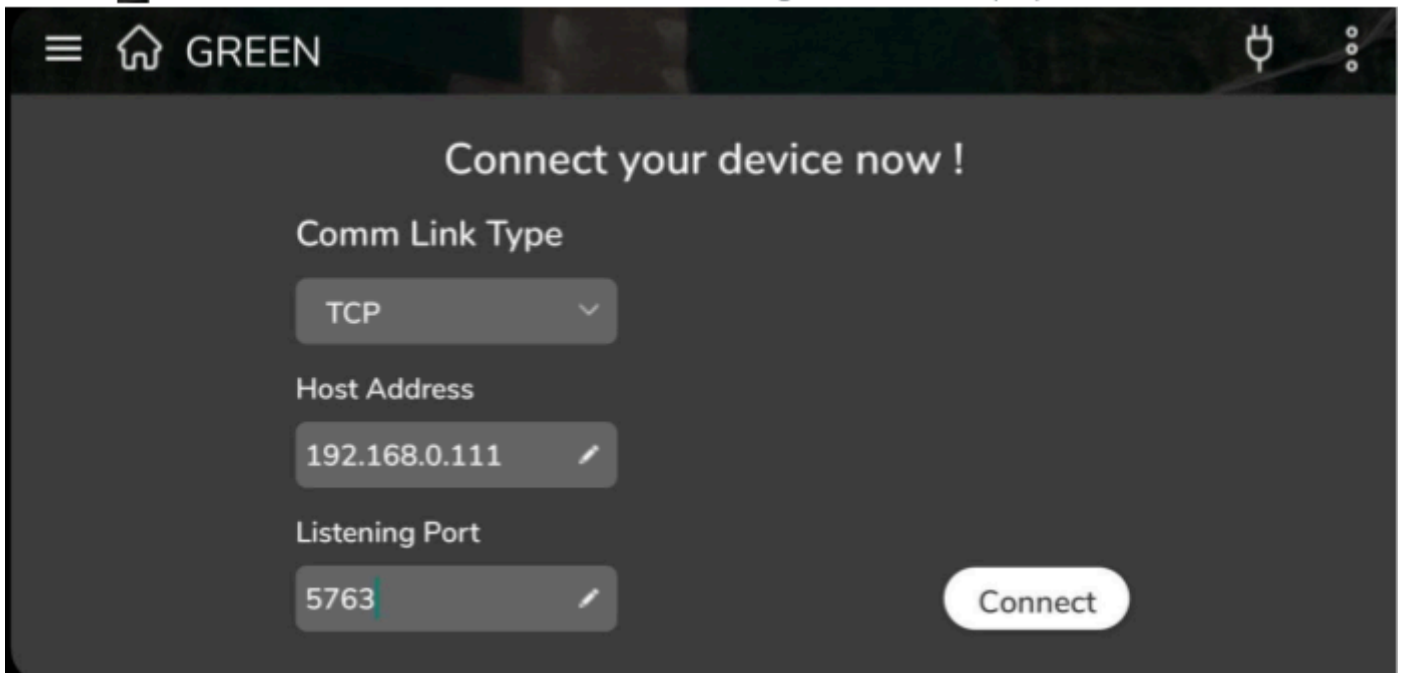

Figure 60 : Connect a Drone

Flight Manual			
Pavaman Aviations Private Limited			
Issue No.	09	Version No.	1.9
Date	22/07/2024	Document Reference	PA - 8

4.1. Communication Link setting:

There are 4 different protocols supported by AeroGCS GREEN through which the user can establish the connection as follows:

4.1.1. Serial Communication:

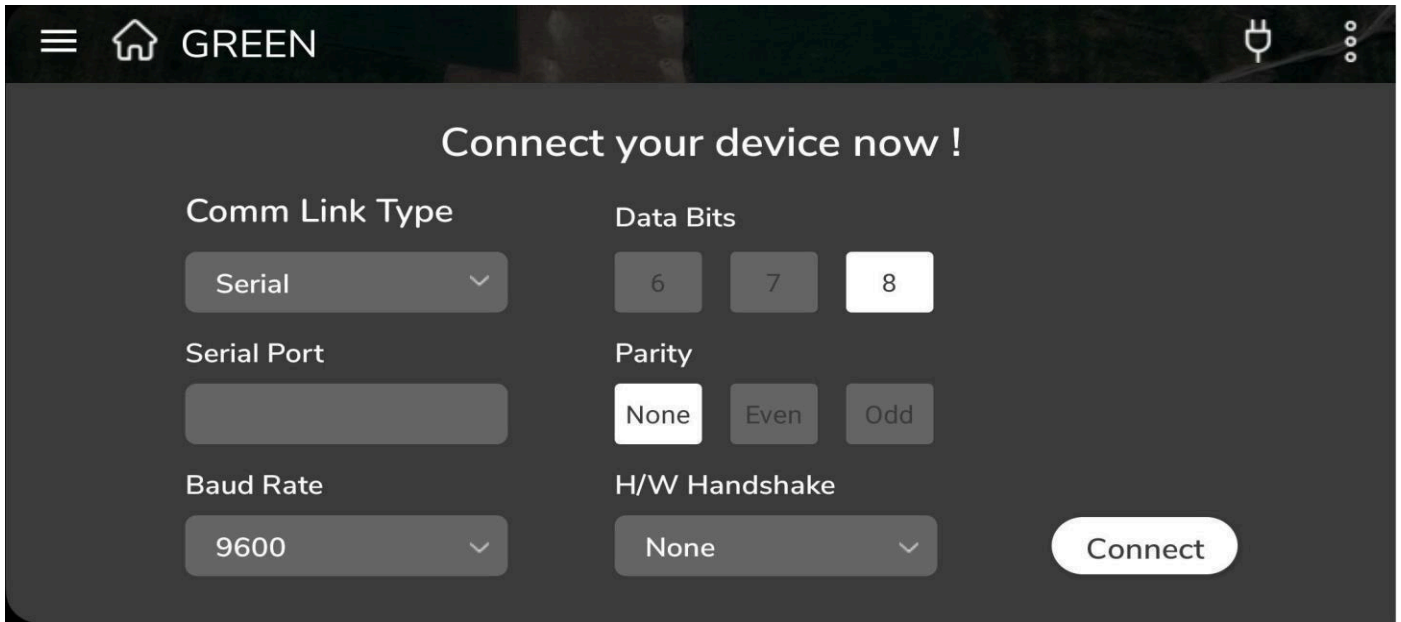

Figure 61 : Serial Port Settings

4.1.2. Baud rate:

Computers communicate by transmitting bits of digital data from one device to another device through transmission media. You can send and receive data without worrying about setting up the details. The baud rate is the rate at which information is transferred in a communication channel. Baud rate is the rate at which the number of signal elements or changes to the signal occurs per second when it passes through a transmission medium. The higher the baud rate the faster is the data sent/received.

Baud rate = number of signal elements/total time (in seconds)

Baud rate is important in the case of serial communication. In the serial port context, "9600 baud" means that the serial port can transfer a maximum of 9600 bits per second.

4.1.3. Parity:

is an error-checking procedure in which the number of 1s must always be the same - either even or odd - for each group of bits that is transmitted without error. In modem-to-modem

<h1>Flight Manual</h1>			
<h2>Pavaman Aviations Private Limited</h2>			
Issue No.	09	Version No.	1.9
Date	22/07/2024	Document Reference	PA - 8

communications, parity is often one of the parameters that must be agreed upon by sending parties and receiving parties before transmission can take place.

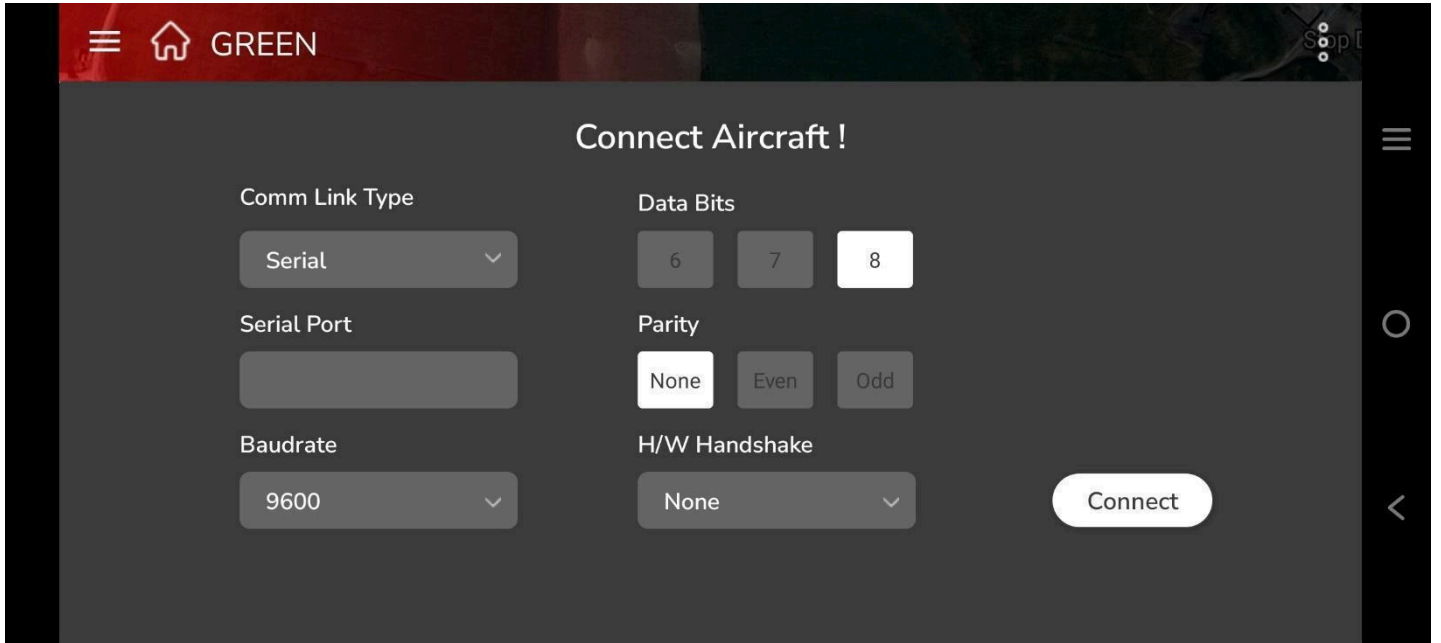

Figure 62 : Baudrate and Parity

4.1.4. UDP (User Datagram Protocol):

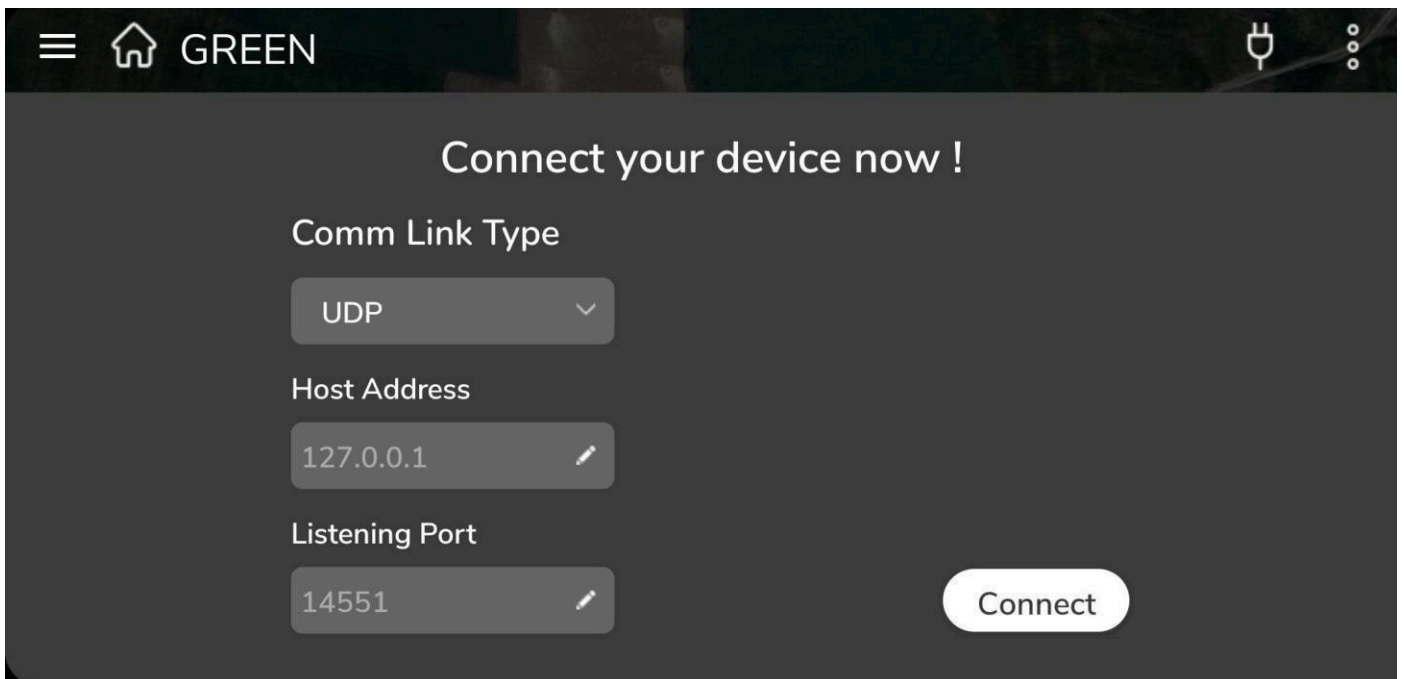

Figure 63 : UDP Communication Settings

Flight Manual			
Pavaman Aviations Private Limited			
Issue No.	09	Version No.	1.9
Date	22/07/2024	Document Reference	PA - 8

User Datagram Protocol (UDP) is a Transport Layer protocol. UDP is a part of the Internet Protocol suite, referred to as UDP/IP suite. Unlike TCP, it is an unreliable and connectionless protocol. So, there is no need to establish a connection before data transfer.

4.1.5. TCP (Transmission Control Protocol):

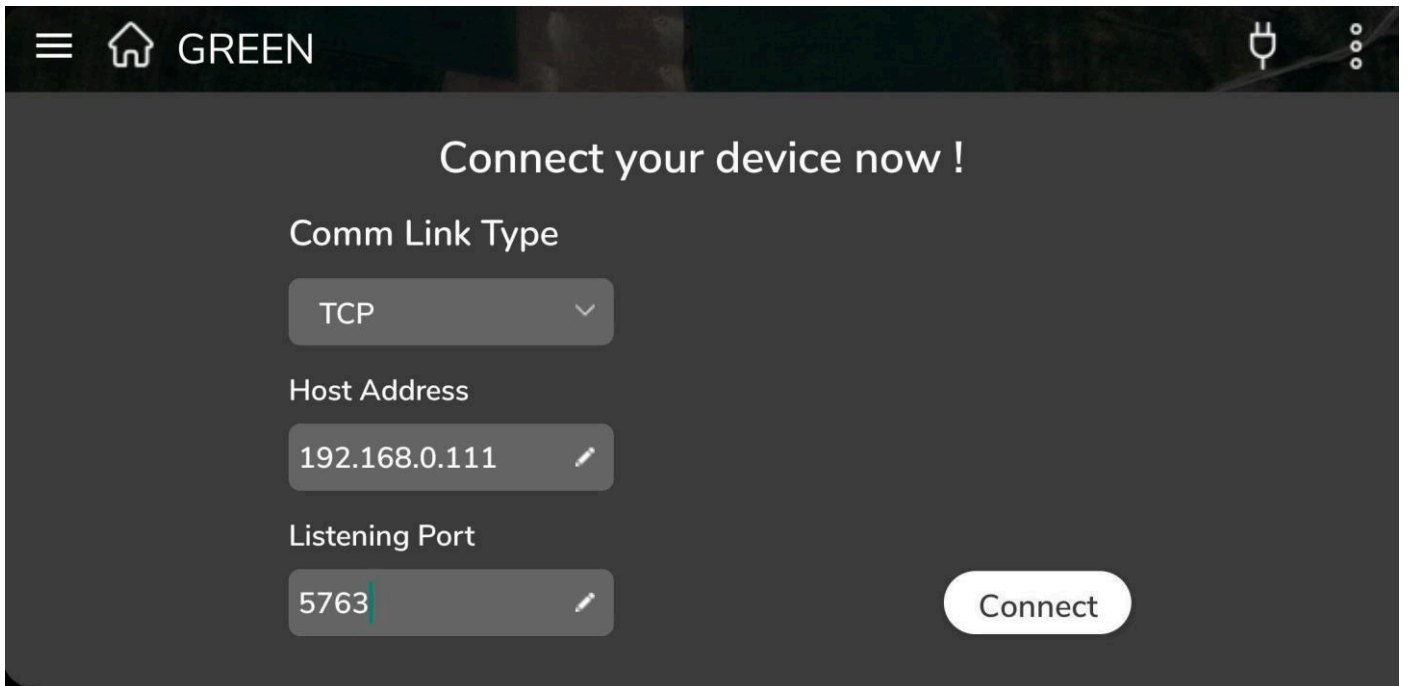

Figure 64 : TCP Connection

In the TCP communication setting, the user can set the host address, listing port, target address, and target port. The User can enter the desired values as per requirement or if the user wants to connect the Herelink then can connect directly without changing the parameters

Enter the required values for the following parameters.

- Host Address
- Listening Port
- Target Address
- Target Port

<h1>Flight Manual</h1>			
<h2>Pavaman Aviations Private Limited</h2>			
Issue No.	09	Version No.	1.9
Date	22/07/2024	Document Reference	PA - 8

4.1.6. Bluetooth

Scan the devices for Bluetooth connection by clicking on the "Scan" button. Select the desired device through the list. Allow the device to access the location of your mobile. Based on the application and the range of the device, the user should select the proper communication protocol

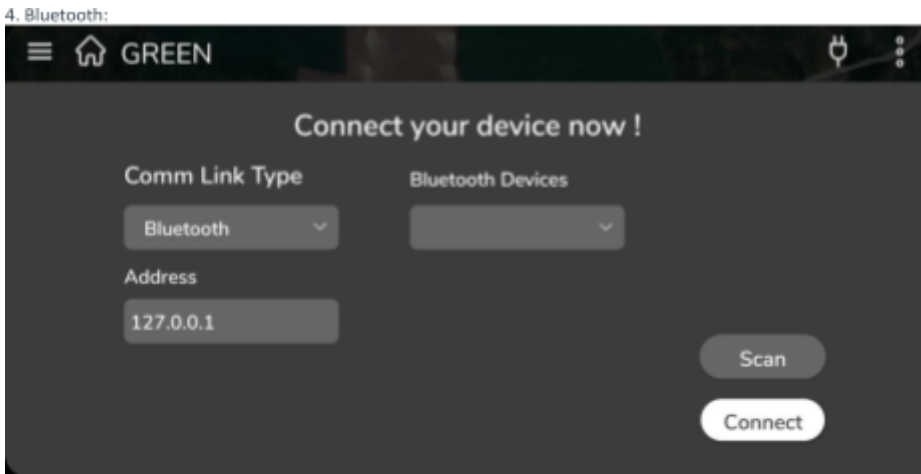

Figure 65 : Bluetooth connection

4.2. RPA Settings

These are the mandatory settings for flying a RPA. To open the RPA settings click on three dots on the right-hand top corner of the dashboard. Select "Settings" option from the popped message.

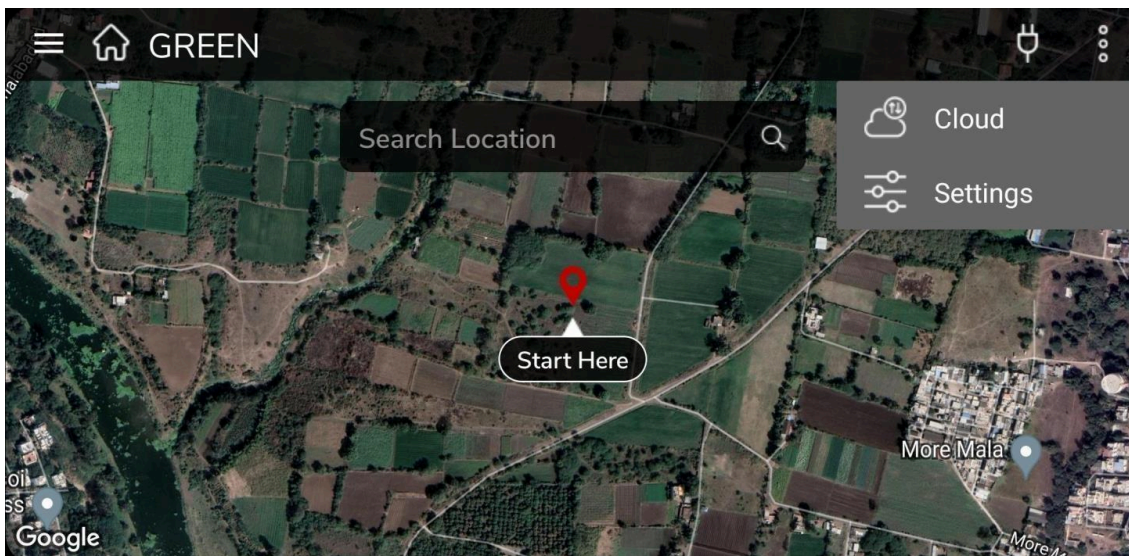

Figure 66 : RPA Settings from Dashboard

Flight Manual			
Pavaman Aviations Private Limited			
Issue No.	09	Version No.	1.9
Date	22/07/2024	Document Reference	PA - 8

RPA Settings will be displayed as shown in the image below:

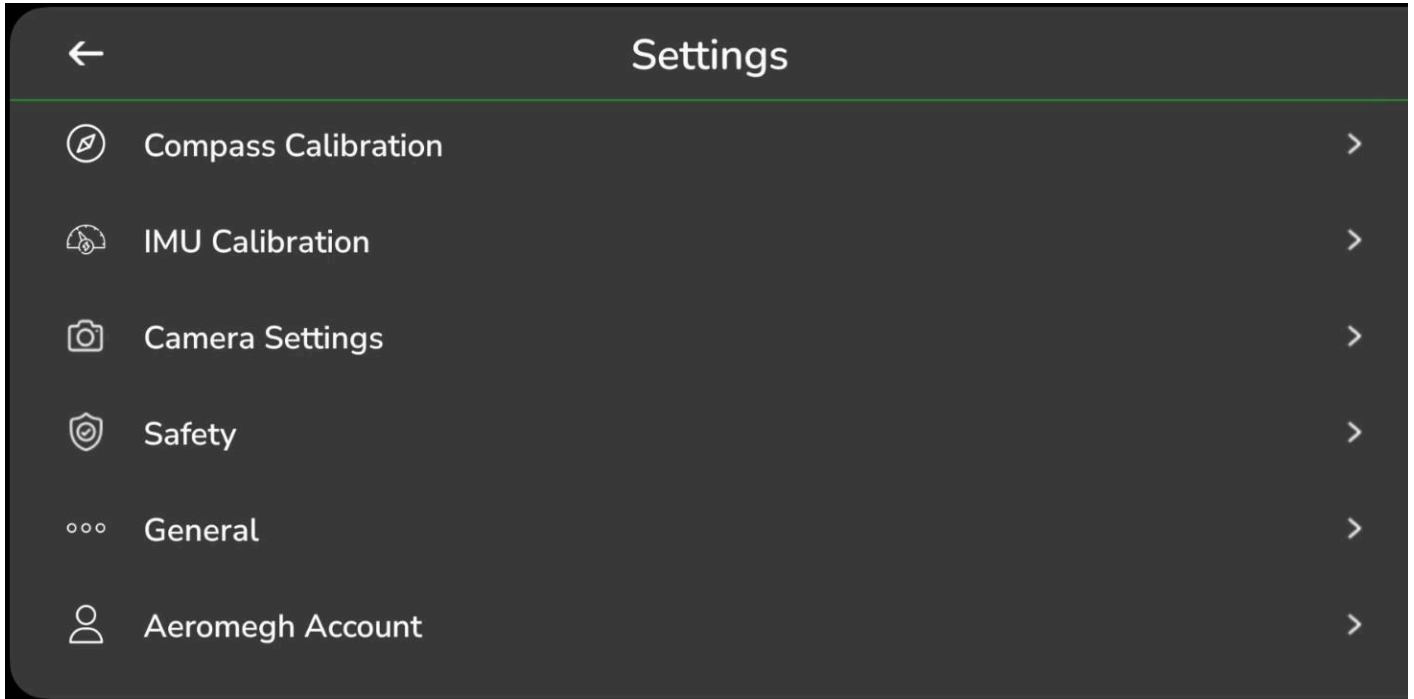

Figure 67: RPA Settings

A detailed description of all these parameters is available in the following section.

A few parameters are to be set through advanced settings of RPA settings of AeroGCS KEA such as follows:

FENCE_RADIUS: Set the radius for a circular fence. This is the value that will be traced always by the system to find out whether the drone is breaching this distance or not. If drones are trying to cross this limit, the RTL will occur as a safety provision.

LOIT_SPEED: Defines the maximum speed in cm/s with which the aircraft will travel horizontally while in loiter mode. The values to be set vary from minimum of 20 to maximum of 800 cm/s.

SPRAY_PUMP_MIN: The minimum required speed of the pump to spray the liquid on the field.

4.3. Aircraft Settings

These settings allow the user to set the required parameters related to the drone or RPA. The following are the settings:

<h1>Flight Manual</h1>			
<h2>Pavaman Aviations Private Limited</h2>			
Issue No.	09	Version No.	1.9
Date	22/07/2024	Document Reference	PA - 8

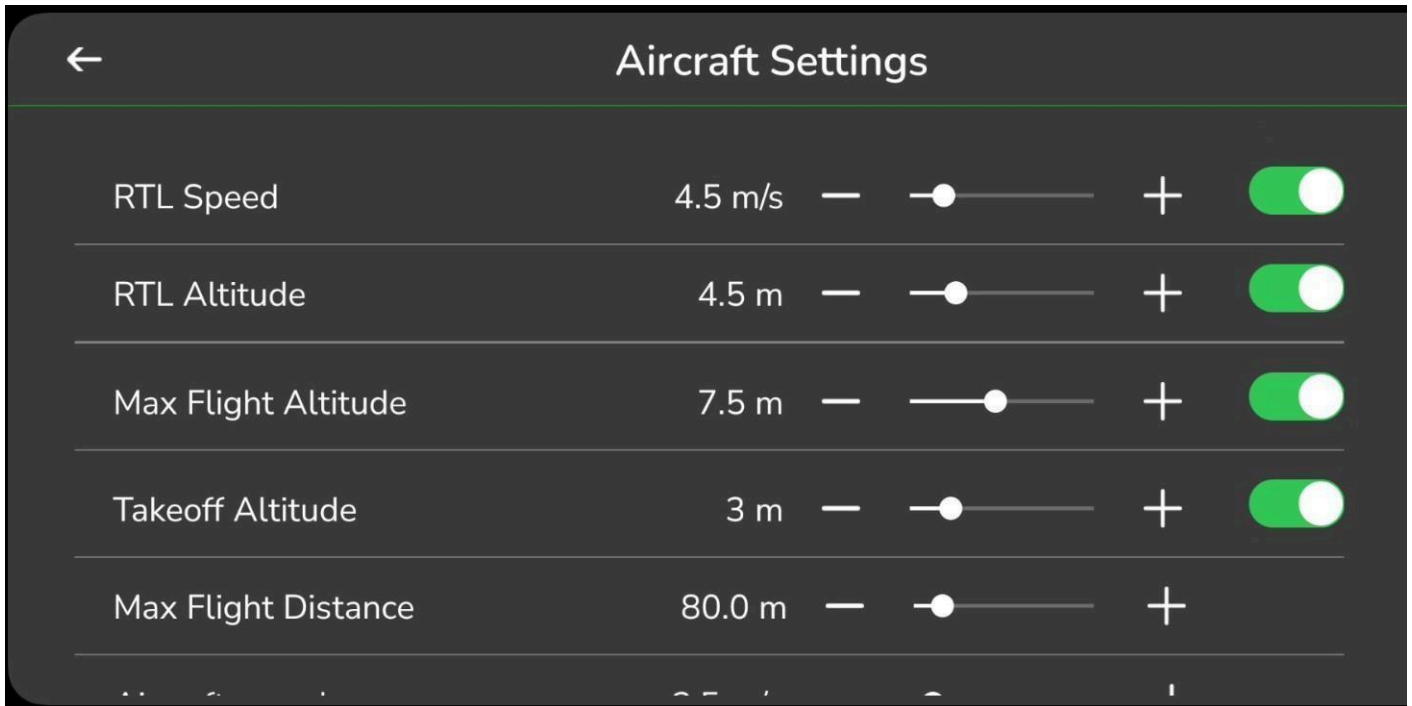

Figure 68 : Aircraft Settings

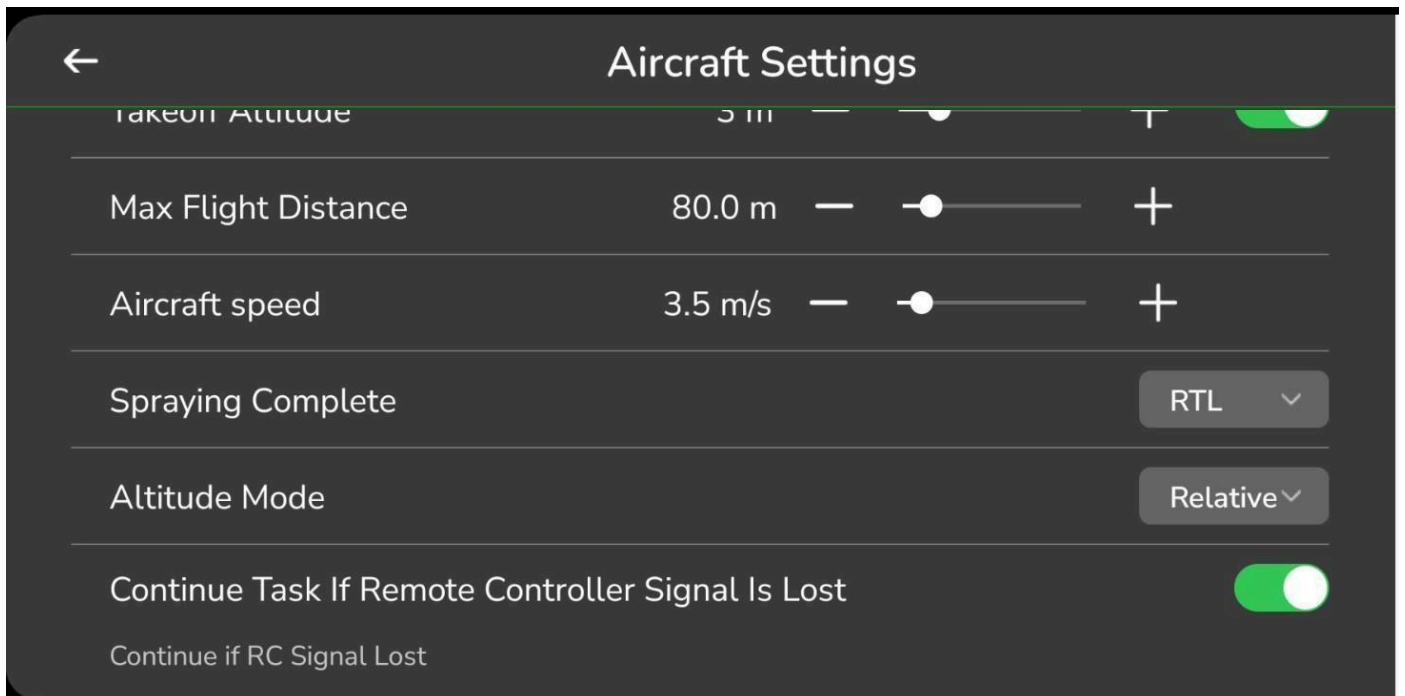

Figure 69 : Aircraft settings

- **RTL Speed:** Set the speed of RPA by changing the position of the slide bar. The RPA speed will be set in m/s.
- **RTL Altitude:** This is the preset Altitude to which the drone will rise before returning to launch.

Flight Manual			
Pavaman Aviations Private Limited			
Issue No.	09	Version No.	1.9
Date	22/07/2024	Document Reference	PA - 8

- **Max Flight Altitude:** This is to be set for safe flying within the rules laid by the government. The maximum altitude that can be set is 30 meters.
- **Take off Altitude:** This is the Altitude that is set while takeoff of the drone. The slide bar allows the user to set this altitude from 1m to 30 m.

Max. Flight Distance: It is the maximum distance that will be covered by a flight.

Aircraft Speed: This parameter will be used to determine the speed of an Aircraft.

Spraying Complete: This setting allows the drone to RTL, Land or Hover after completing the spraying on the plan. **Altitude Mode:** By using this parameter the user will be able to set an altitude mode to either Relative or Terrain as per the requirement of an application.

Relative Mode: The drone altitude will be set to the relative altitude normally to follow the set altitude.

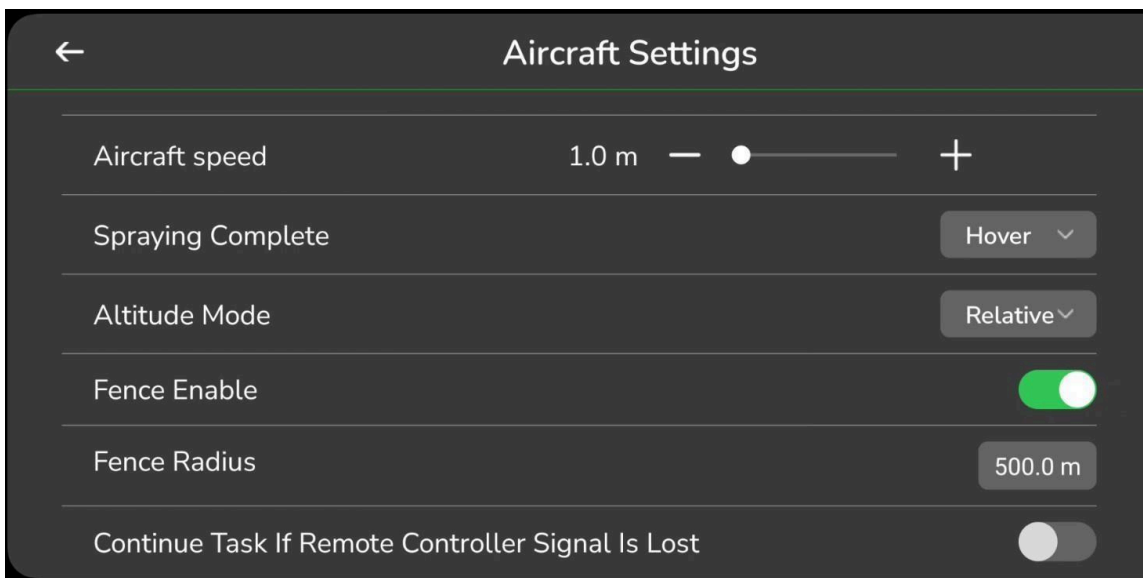

Figure 71 : Fence Parameters

Fence Enable: The user may enable the fence using this setting.

Fence Radius: enter the radius of the fence.

Continue Task if remote control signal is lost: Disabling this button will cause the drone to return to launch in case of Signal loss from the remote controller.

Flight Manual			
Pavaman Aviations Private Limited			
Issue No.	09	Version No.	1.9
Date	22/07/2024	Document Reference	PA - 8

4.3.1. GEO- FENCE



Figure : Shows the fence breach failsafe

Connect the transmitter and GCS. Connect the battery with the drone. Fly the drone. Once it reaches the altitude of 30 m or distance of 500m, it will pop up with an indication showing “Fence Breached” And the drone will trigger RTL.

Upon entering FAILSAFE mode, the RPA will fly directly back to the Home Position (Launch area) following the shortest path at the current altitude.

4.4. Spraying System

These are the settings related to spraying. AeroGCS GREEN allows user to set different parameters related to the pump, tank, and a few emergency settings.

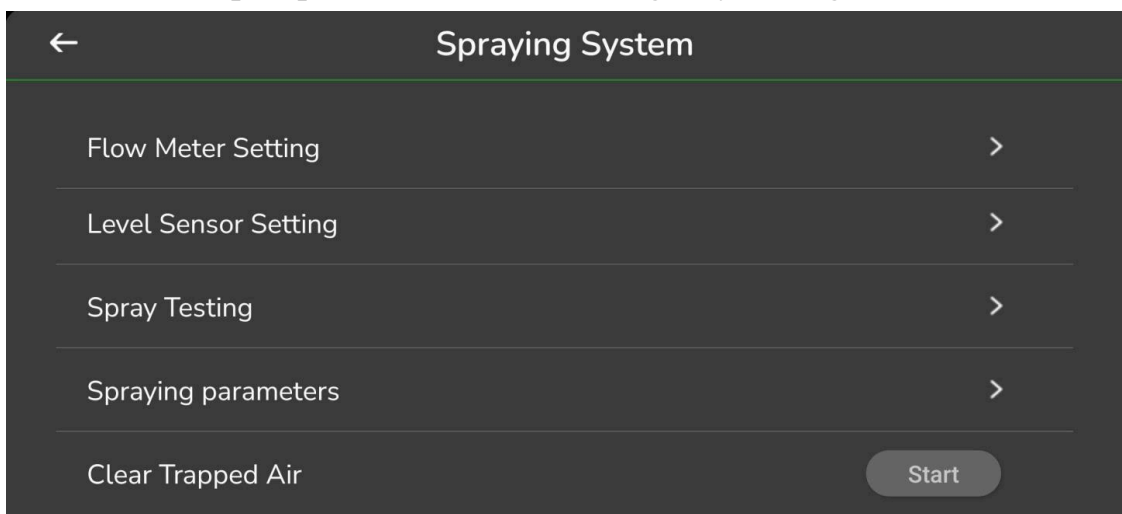

Figure 72 : Spraying System

Flight Manual			
Pavaman Aviations Private Limited			
Issue No.	09	Version No.	1.9
Date	22/07/2024	Document Reference	PA - 8

Liquid Tank Capacity: Set the tank's maximum capacity in mili-liter (ml).
 After settings all these parameters upload these settings and move further.

Level Sensor Setting

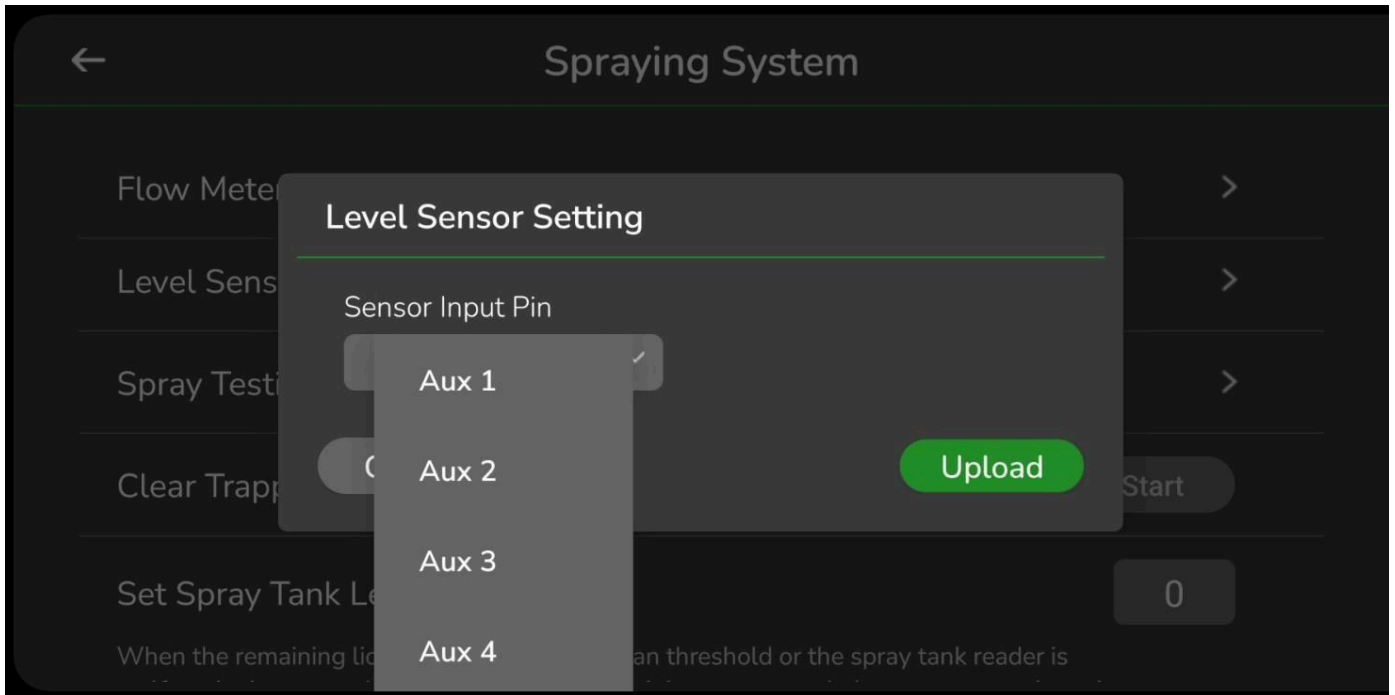

Figure 75: Level Sensor Setting

Select the Sensor input pin where the level sensor is connected to the drone. Select the input pin from the dropdown list as shown in the above image. Click on the "Upload" button to upload the level sensor setting.

Flight Manual			
Pavaman Aviations Private Limited			
Issue No.	09	Version No.	1.9
Date	22/07/2024	Document Reference	PA - 8

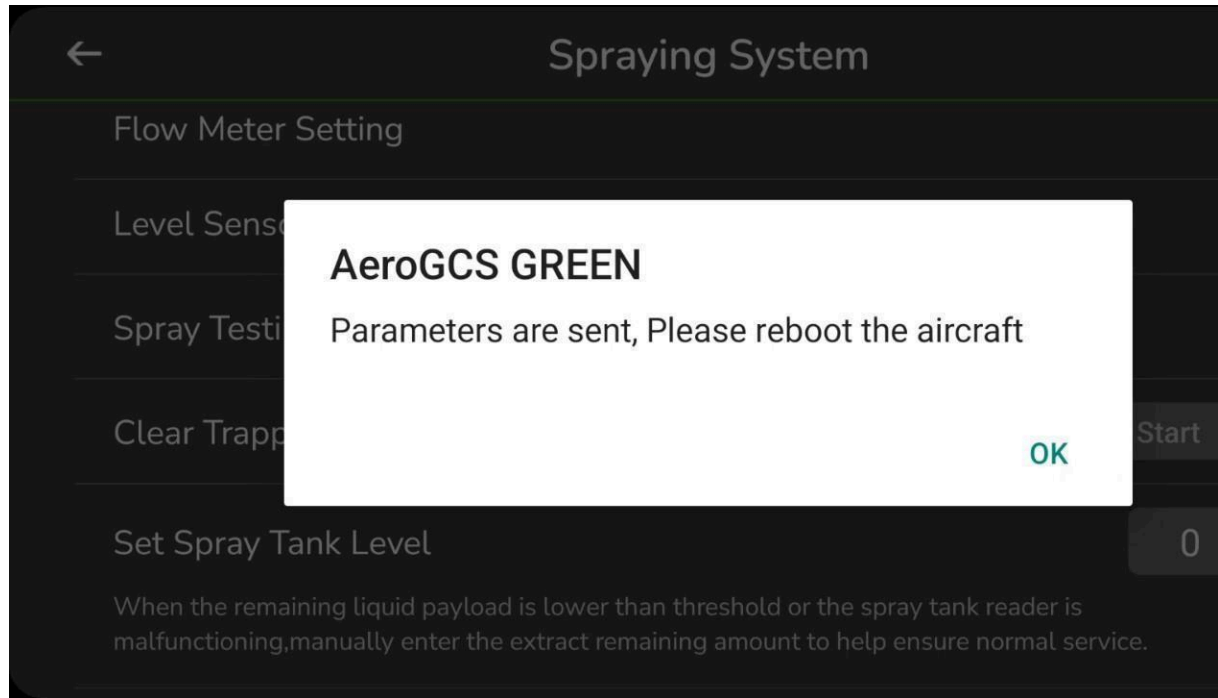

Figure 76 : Level Sensor Setting Applied

Follow the instructions that popped up on the screen to proceed with newly changed settings. Press the “OK” button.

Spray Testing

The user can test the spraying speed before the actual flight by using this functionality.

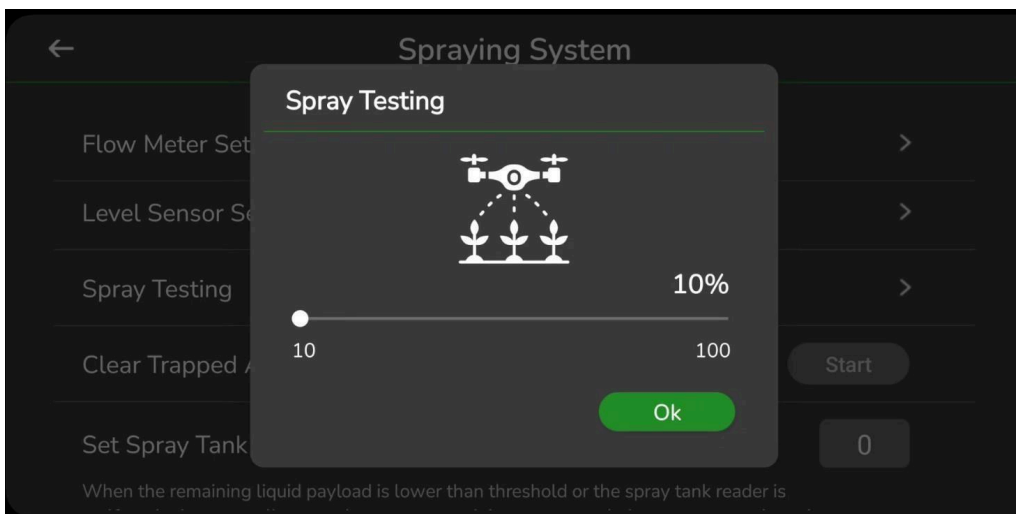

Figure 77 : Spray Testing

Flight Manual			
Pavaman Aviations Private Limited			
Issue No.	09	Version No.	1.9
Date	22/07/2024	Document Reference	PA - 8

Change the percentage of spraying with the slide bar and click on the "Ok" button to test it with that value. Make sure the tank is filled with liquid and the pumps are on.

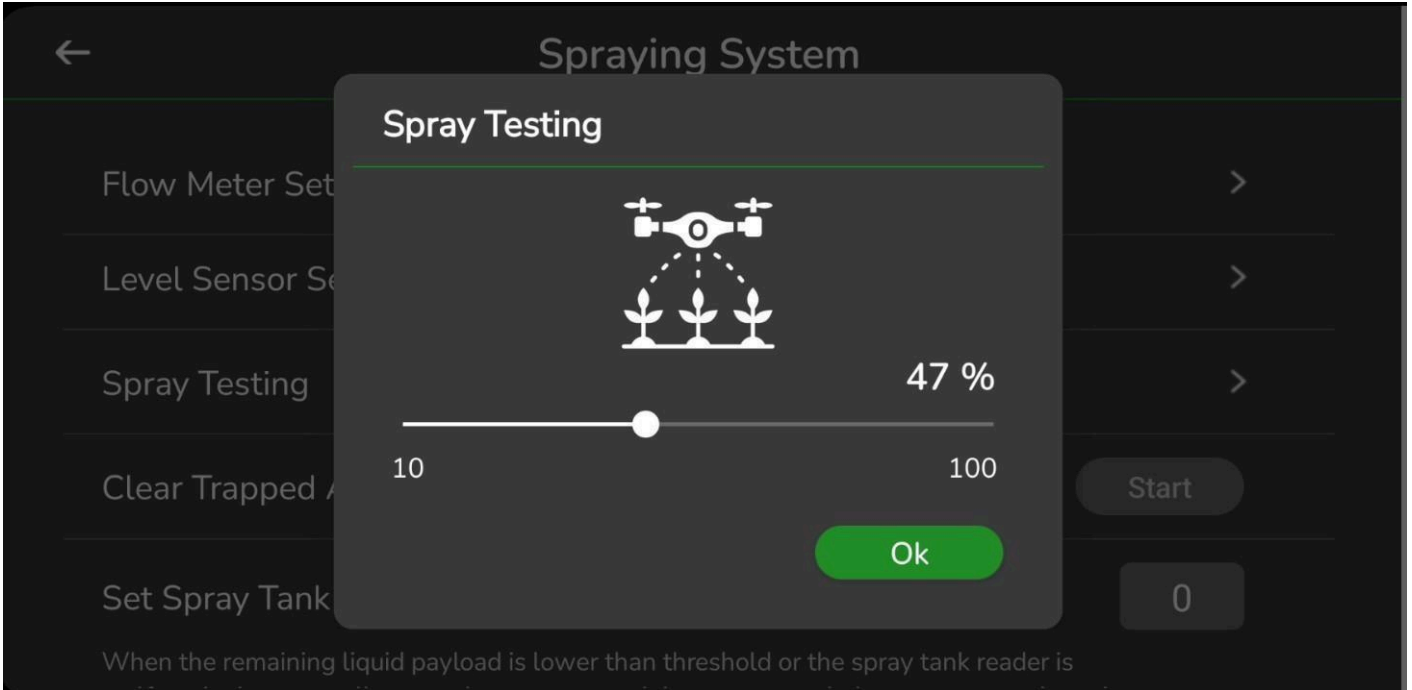

Figure 78 : Spray Testing with desired values

Spraying Parameters

Set the parameters for spraying the liquid according to the requirements of an application and type of pesticide, insecticide, or fertilizer.

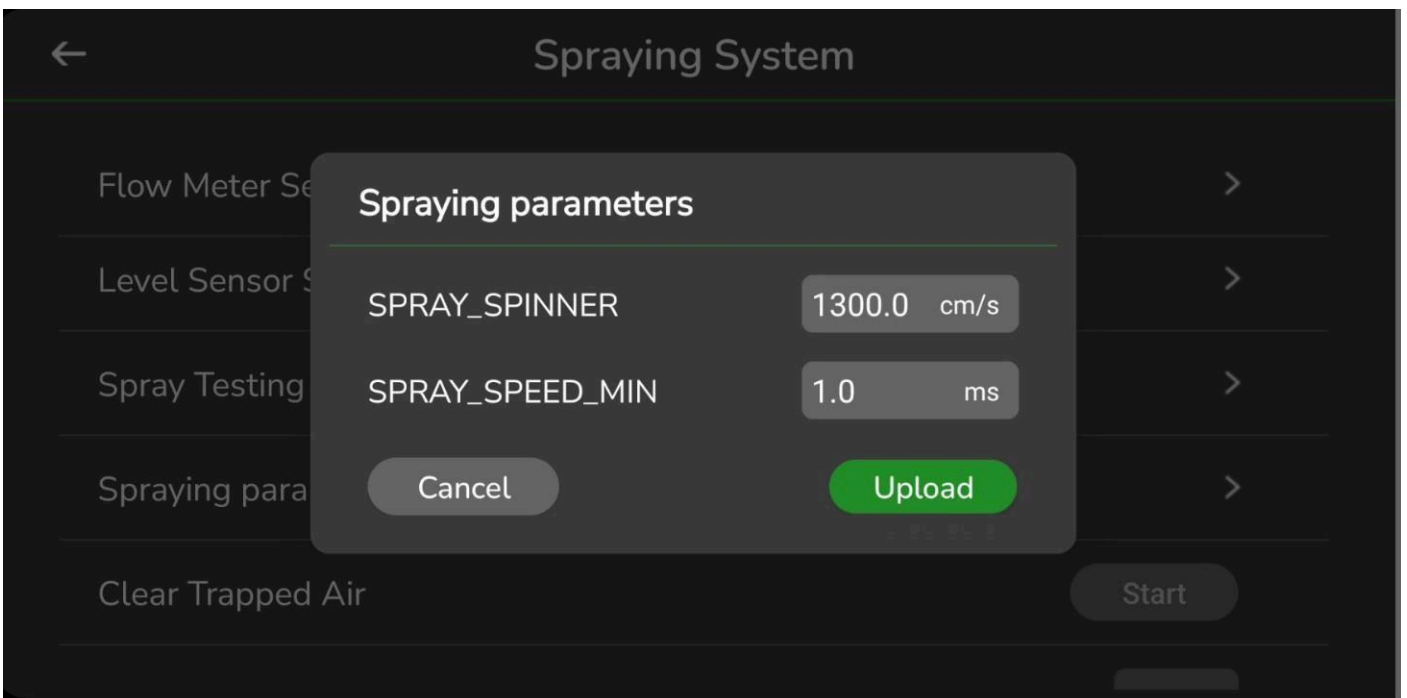

Figure 79 : Spraying Parameters

Flight Manual			
Pavaman Aviations Private Limited			
Issue No.	09	Version No.	1.9
Date	22/07/2024	Document Reference	PA - 8

SPRAY_SPINNER: Set the speed of spray spinning in 'cm/s'.

SPRAY_SPEED_MIN: Set the minimum speed of spraying in 'ms'.

Clear Trapped Air

This setting clears all the disturbances in spraying the liquid like clearing trapped air. Make sure that the pump is turned on for this process. If yes, then click "Start" to clear trapped air operation.

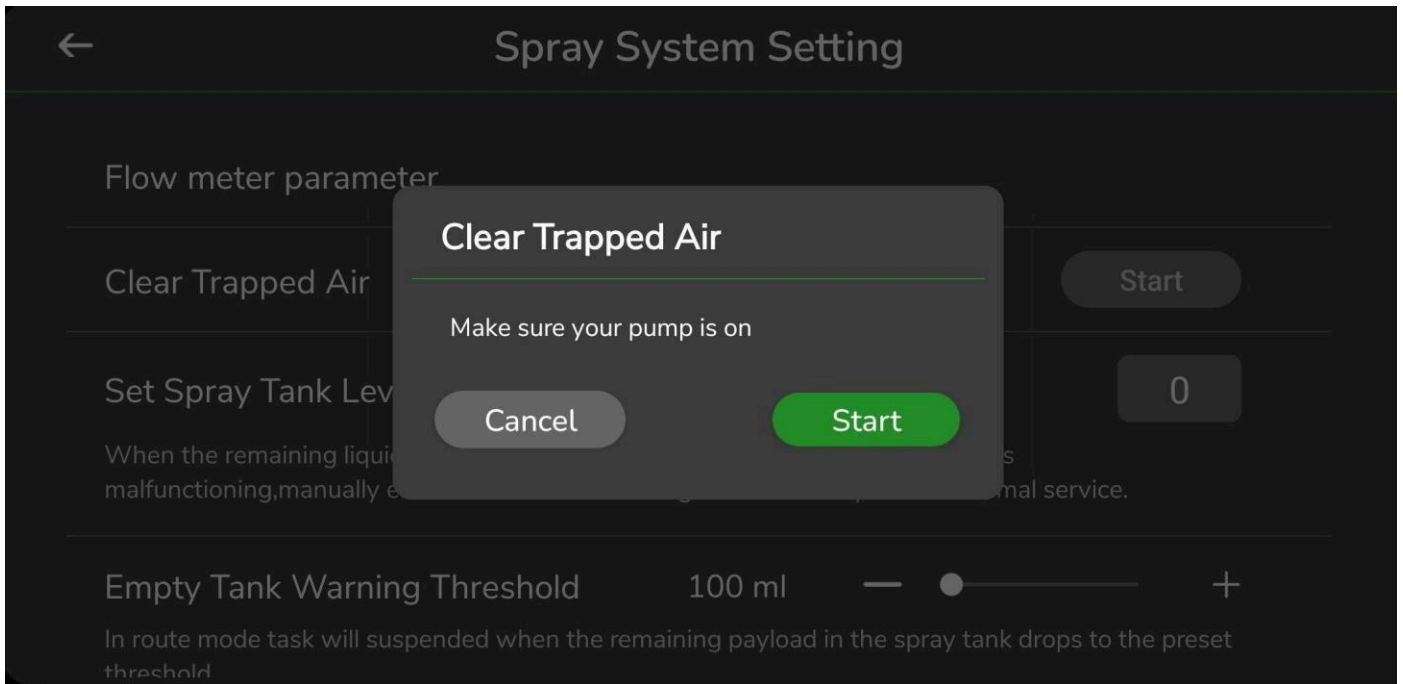

Figure 80 : Clear Trapped Air

Set Spray Tank Level

When the remaining liquid payload is lower than threshold or the spray tank reader is malfunctioning, manually enter the exact remaining amount to help ensure normal service.

Empty Threshold Action

This parameter will raise the warning message when the payload in the spray tank drops to the preset threshold. The user can set the empty threshold action as follows:

RTL: Return to Launch after the level of liquid in the tank crosses the threshold level.

Hover: Hover when the liquid in the tank crosses the threshold level.

None: Assign no action when the liquid in the tank crosses the threshold level.

Flight Manual			
Pavaman Aviations Private Limited			
Issue No.	09	Version No.	1.9
Date	22/07/2024	Document Reference	PA - 8

None: Assign no action on crossing the level of the liquid in the tank.



Figure 81 : Empty threshold action

4.4.1. Flow Meter Error Alert

The alert will be generated by a remote control when there is a large difference between standard and active flow levels. The user can set a minimum of 1% to a maximum of 20%.

Calibrate Pump Flow

Calibrate the pumps in the case of inconsistent spraying, change in the type of nozzle, or pump is replaced.

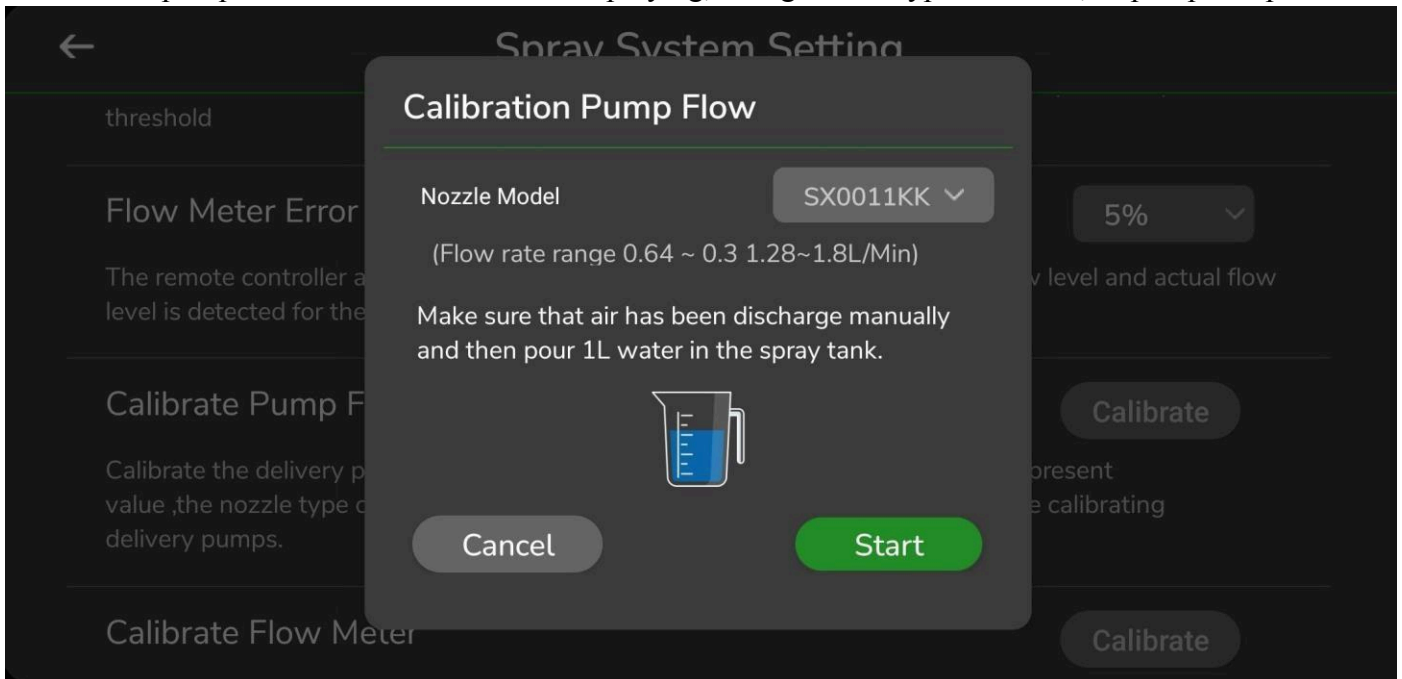

Figure 3.3.85:Calibration of Pump Flow

Click on the "Start" button to start the calibration of the pump flow. Make sure that air has been discharged

Flight Manual			
Pavaman Aviations Private Limited			
Issue No.	09	Version No.	1.9
Date	22/07/2024	Document Reference	PA - 8

manually and then pour 1 liter of water into a spray tank. Click on the 'Start' button to start the calibration process.

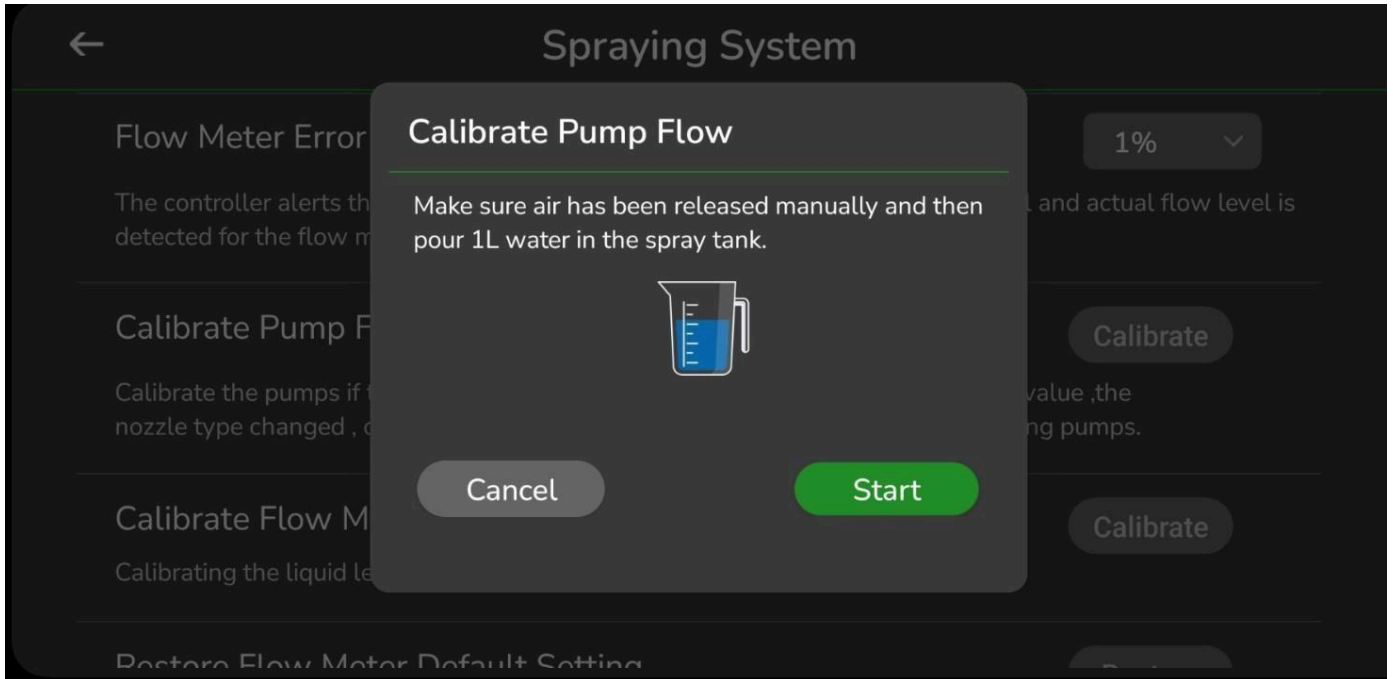

Figure 3.3.86: Calibrate Pump Flow

Follow the instructions appearing on the screen as shown in image.

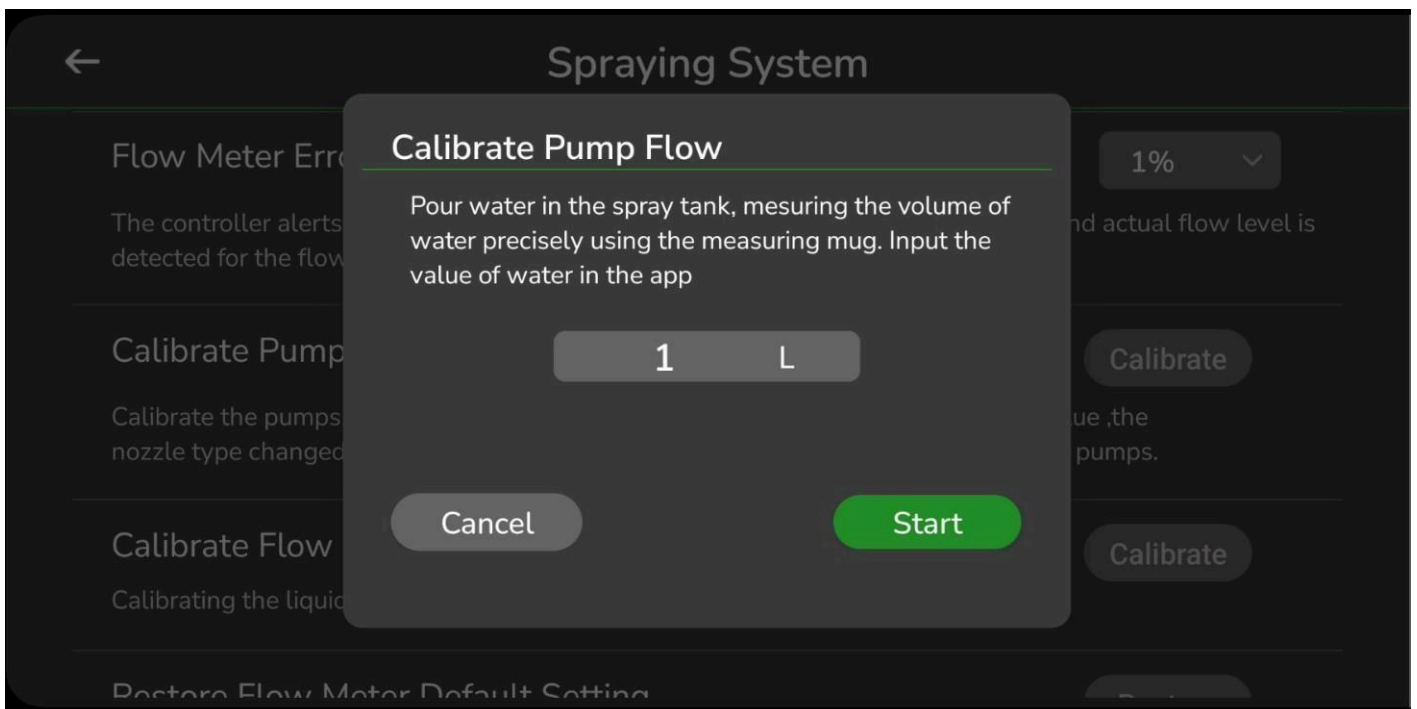

Figure 3.3.87: Calibrate Pump Flow

Wait till the calibration is completed. After the completion of the process, click on the 'Done' button to proceed.

Flight Manual			
Pavaman Aviations Private Limited			
Issue No.	09	Version No.	1.9
Date	22/07/2024	Document Reference	PA - 8

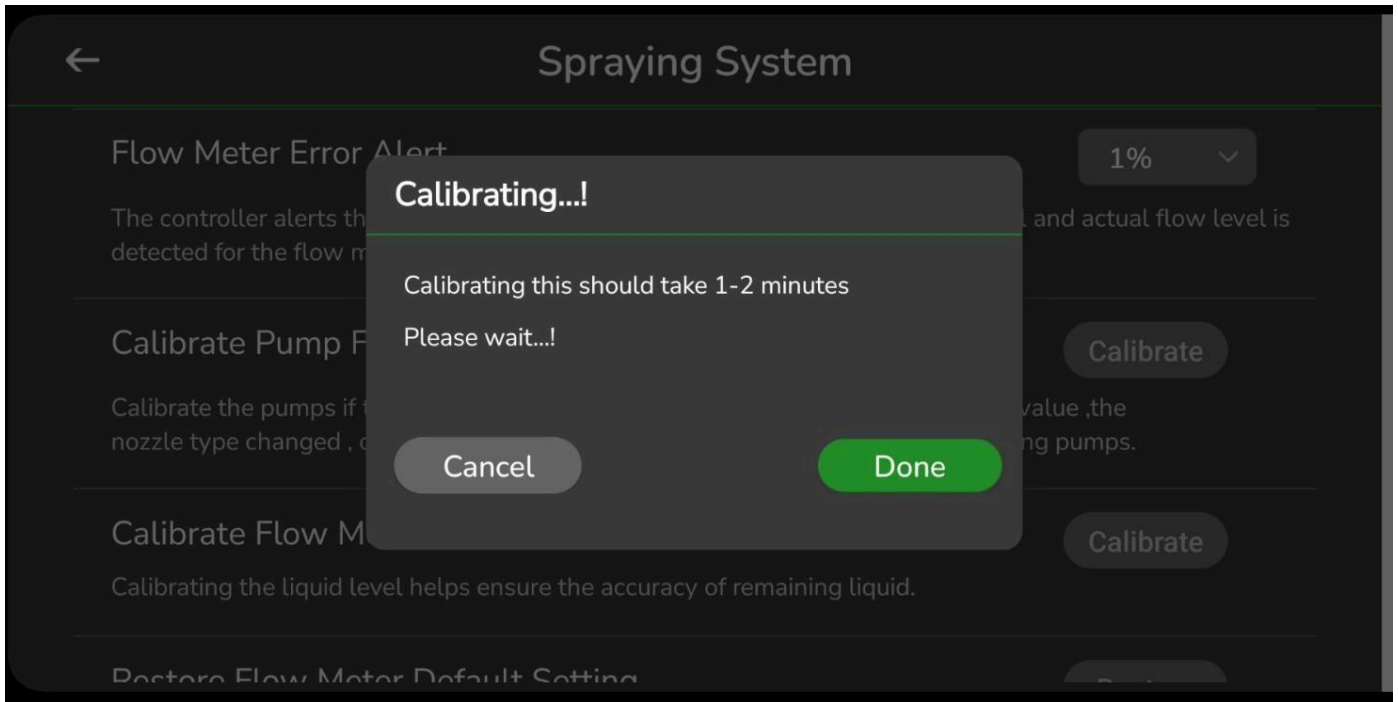

Figure 3.3.88: Calibrating Pump Flow

Calibrate Flow Meter

Calibrating the liquid level helps to ensure the accuracy of the remaining payload. Click on the "Start" button to calibrate the flow meter. Follow the instructions popped on the screen to get good results.

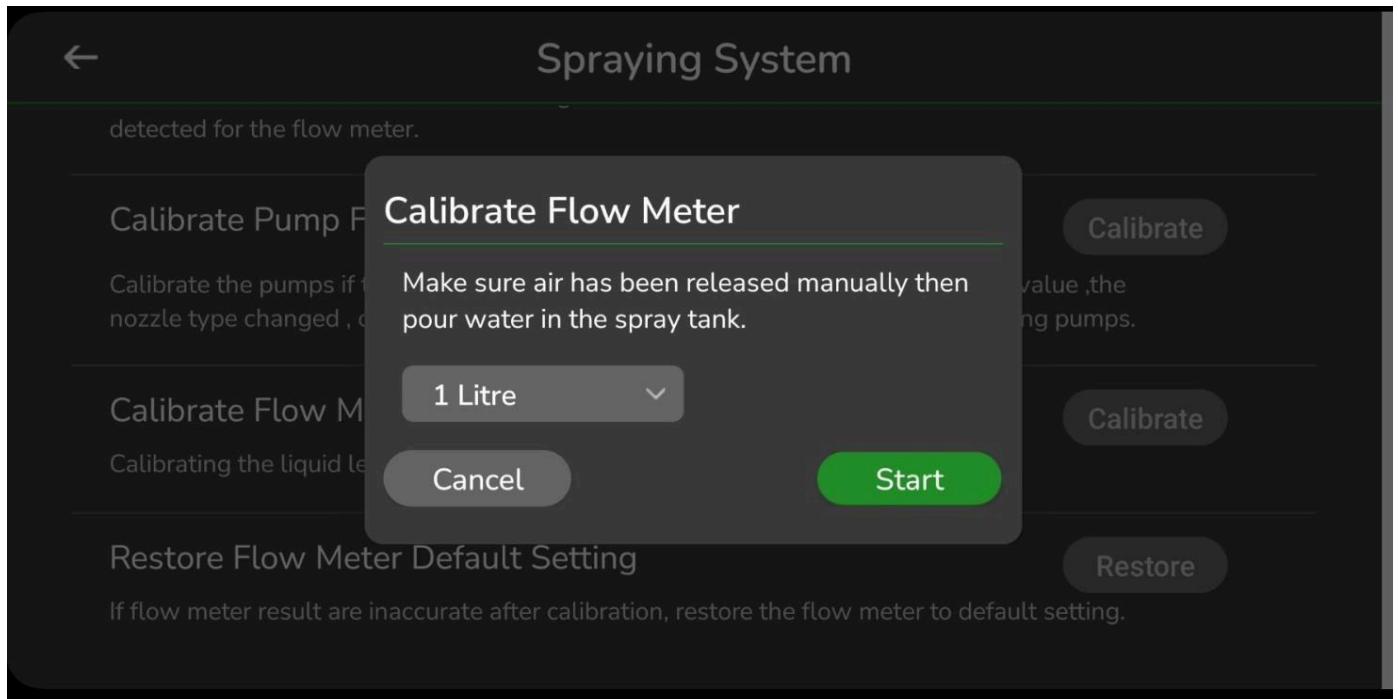

Figure 3.3.89: Calibration of Flowmeter

Flight Manual			
Pavaman Aviations Private Limited			
Issue No.	09	Version No.	1.9
Date	22/07/2024	Document Reference	PA - 8

After releasing air from the tank and pipe, pour the water into the tank. Select the capacity of a tank from the dropdown menu and click on the 'Start' button to start the process of flow meter calibration.

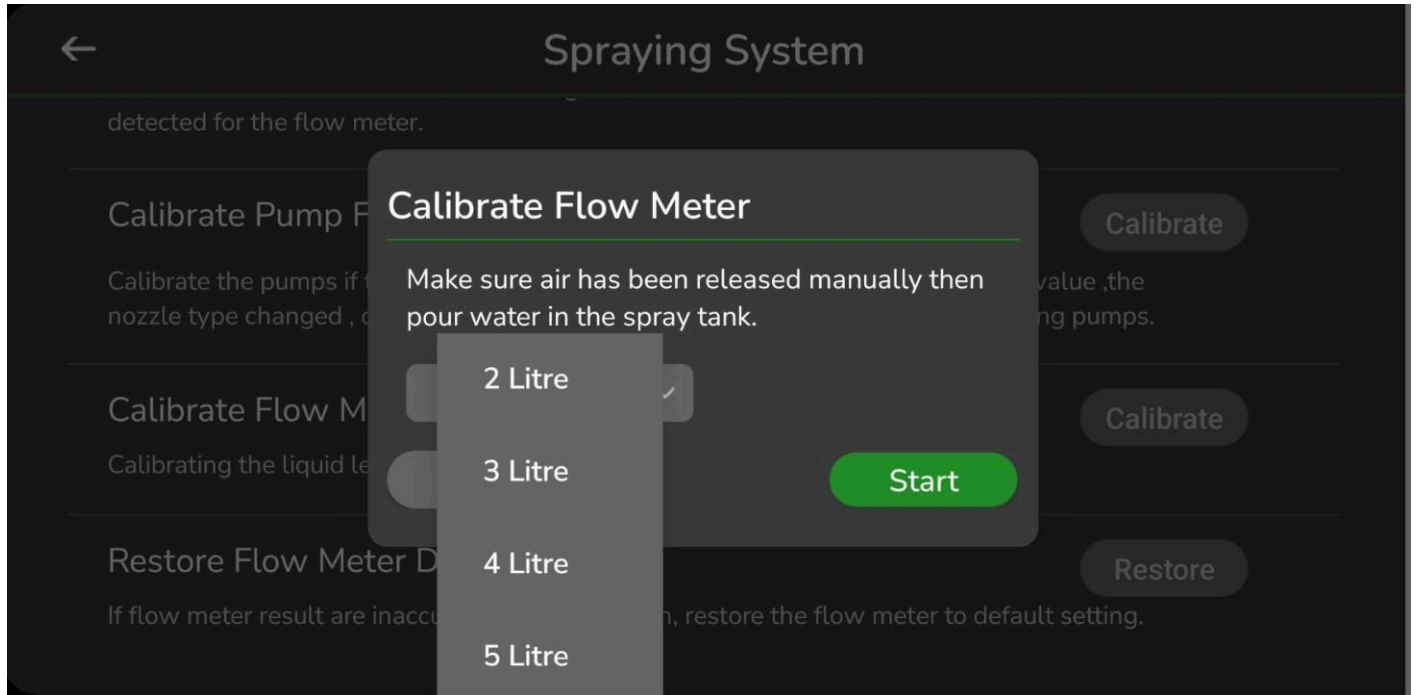

Figure 3.3.90: Select Capacity of Tank

Follow the instructions popping on the screen to complete the process of calibration. Once the process is completed, click on the 'Stop' button.

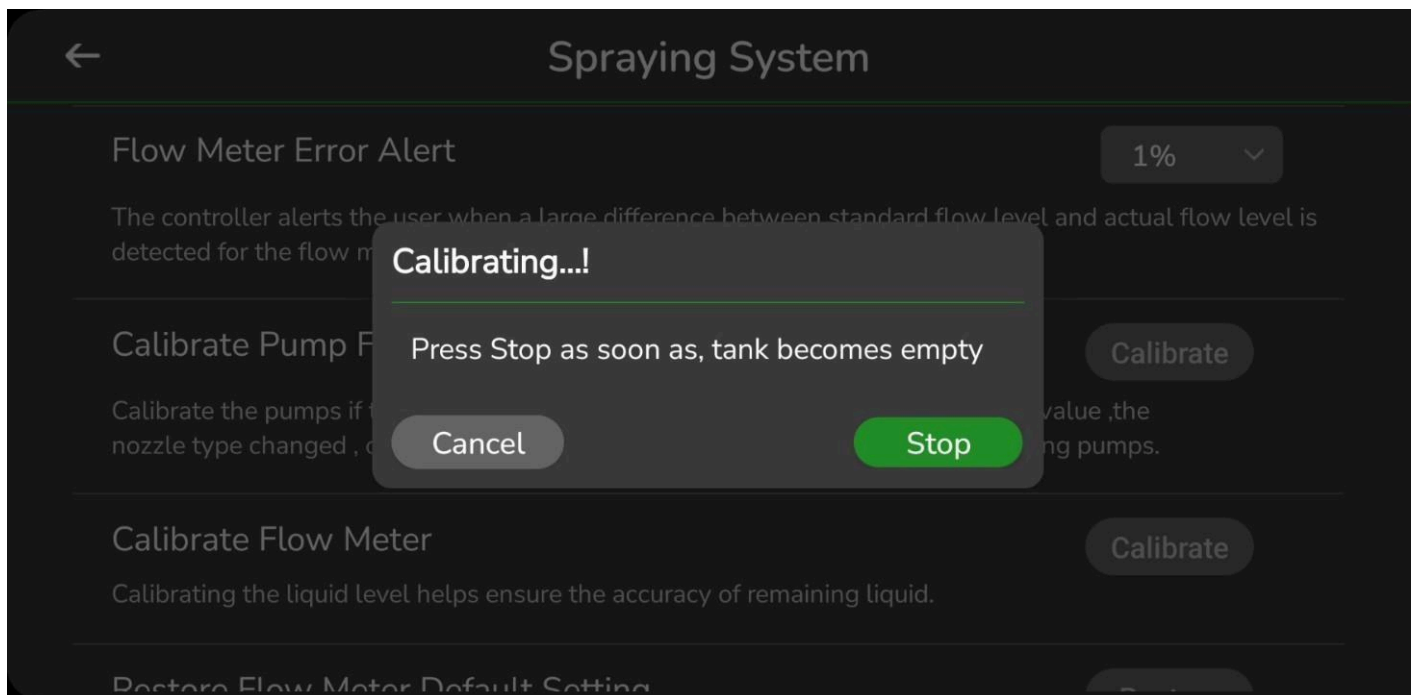

Figure 3.3.91: Calibrating Flow meter

Flight Manual			
Pavaman Aviations Private Limited			
Issue No.	09	Version No.	1.9
Date	22/07/2024	Document Reference	PA - 8

Restore flow Meter to Factory Setting

If the flow meter is giving inaccurate results after calibration, then restore the flow meter to get the accurate results.

Remote Controller Settings

These are the settings that are related to Remote Controller Calibration. The radio is calibrated for roll, pitch, yaw, and throttle by clicking on the "Calibrate" button.

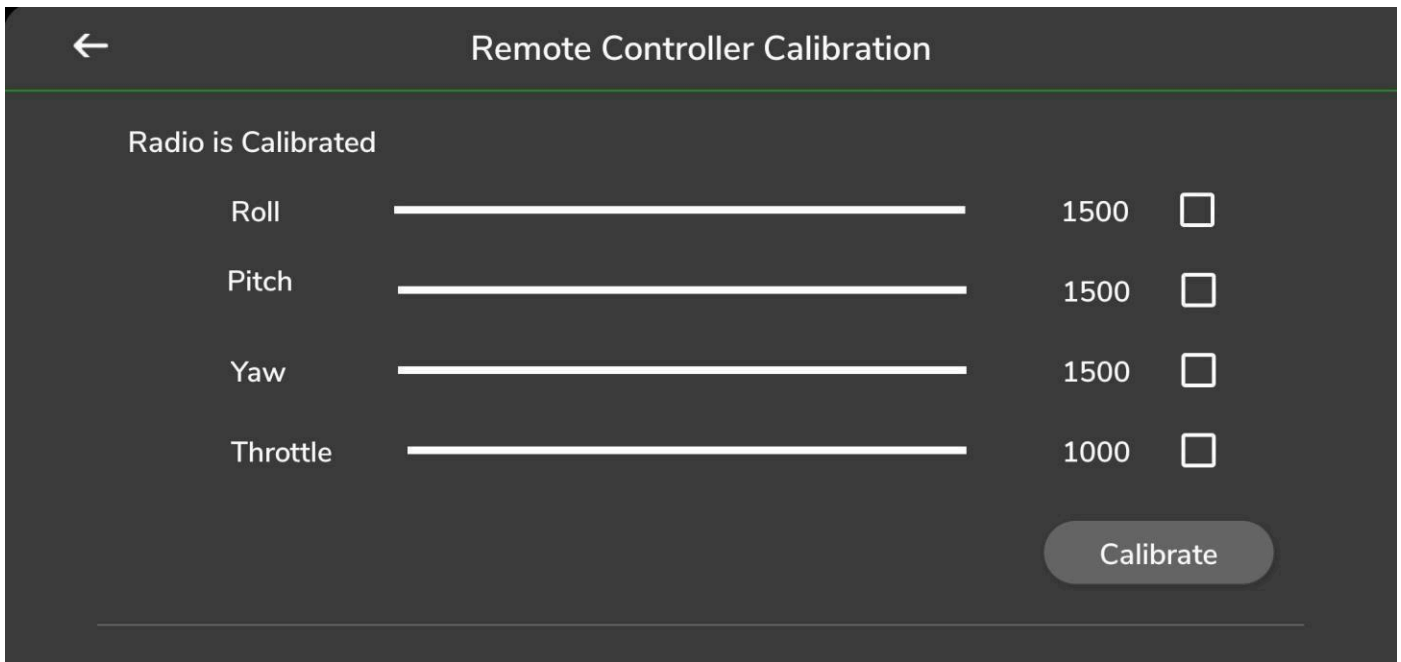

Figure 3.3.92: RC Calibration

Calibrate the radio for roll, pitch, yaw, and throttle values. Follow the instructions displayed on the screen.

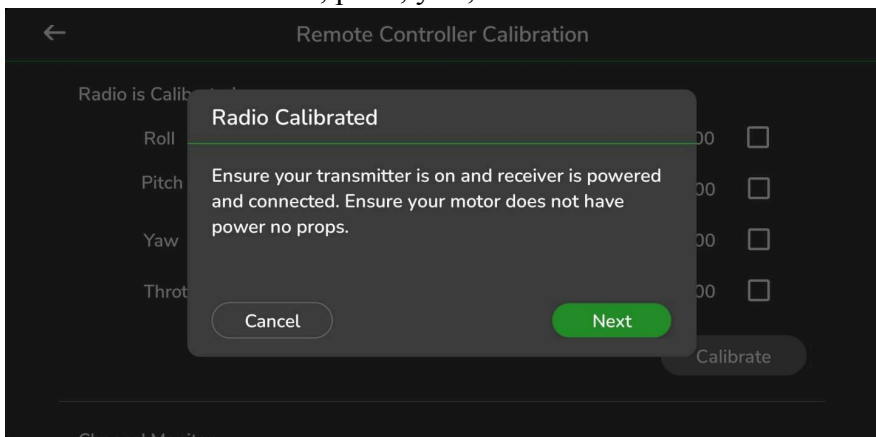

Figure 3.3.93: Radio Calibration

<h1>Flight Manual</h1>			
<h2>Pavaman Aviations Private Limited</h2>			
Issue No.	09	Version No.	1.9
Date	22/07/2024	Document Reference	PA - 8

Once the calibration is done it will display all the values collectively as shown in the image.

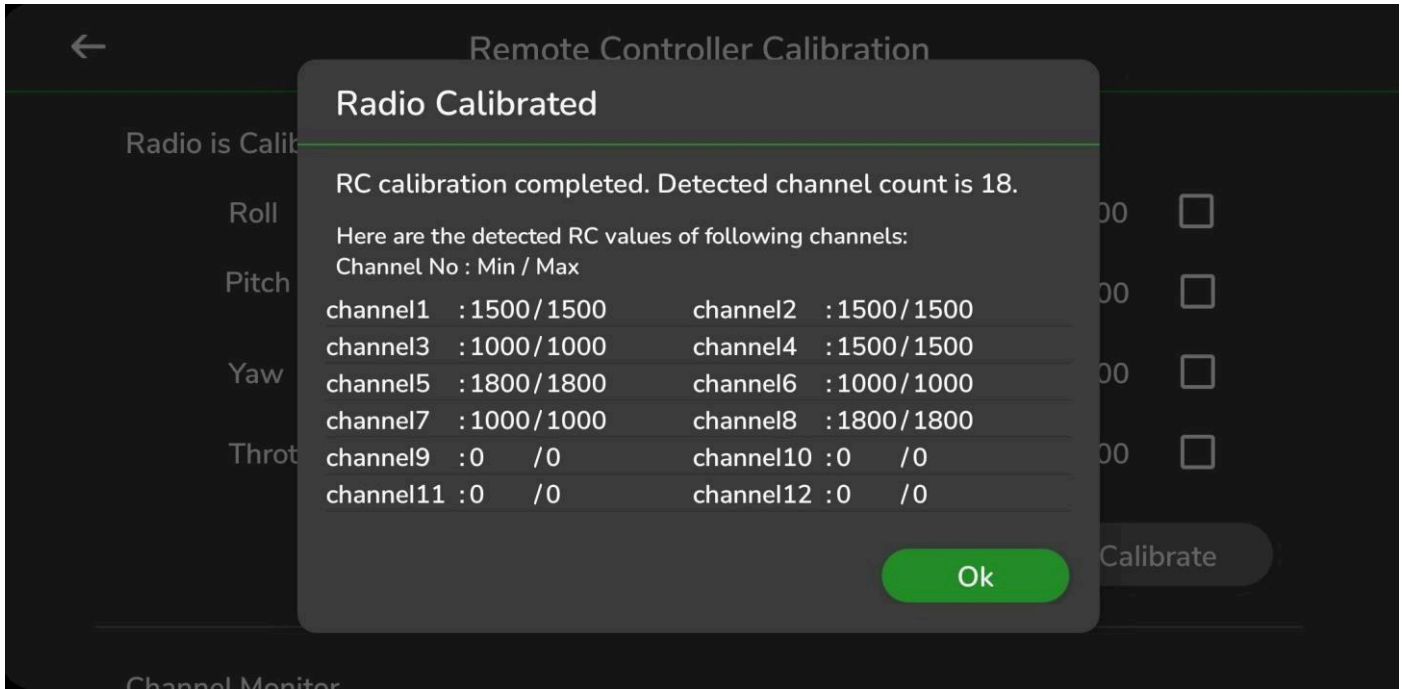

Figure 3.3.94: Radio Calibrated

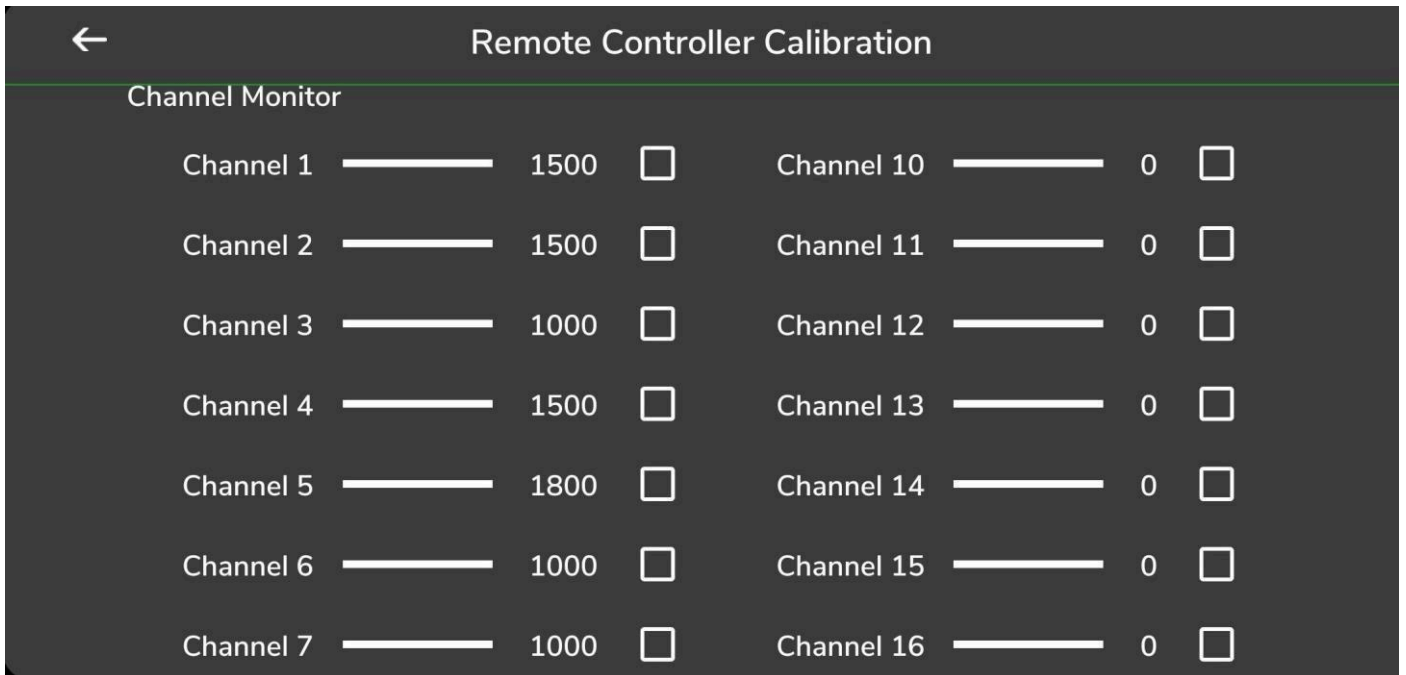

Figure 3.3.95: Remote Controller Calibration

Advance settings allow customizing the buttons of RC as shown in the image below.

<h1>Flight Manual</h1>			
<h2>Pavaman Aviations Private Limited</h2>			
Issue No.	09	Version No.	1.9
Date	22/07/2024	Document Reference	PA - 8

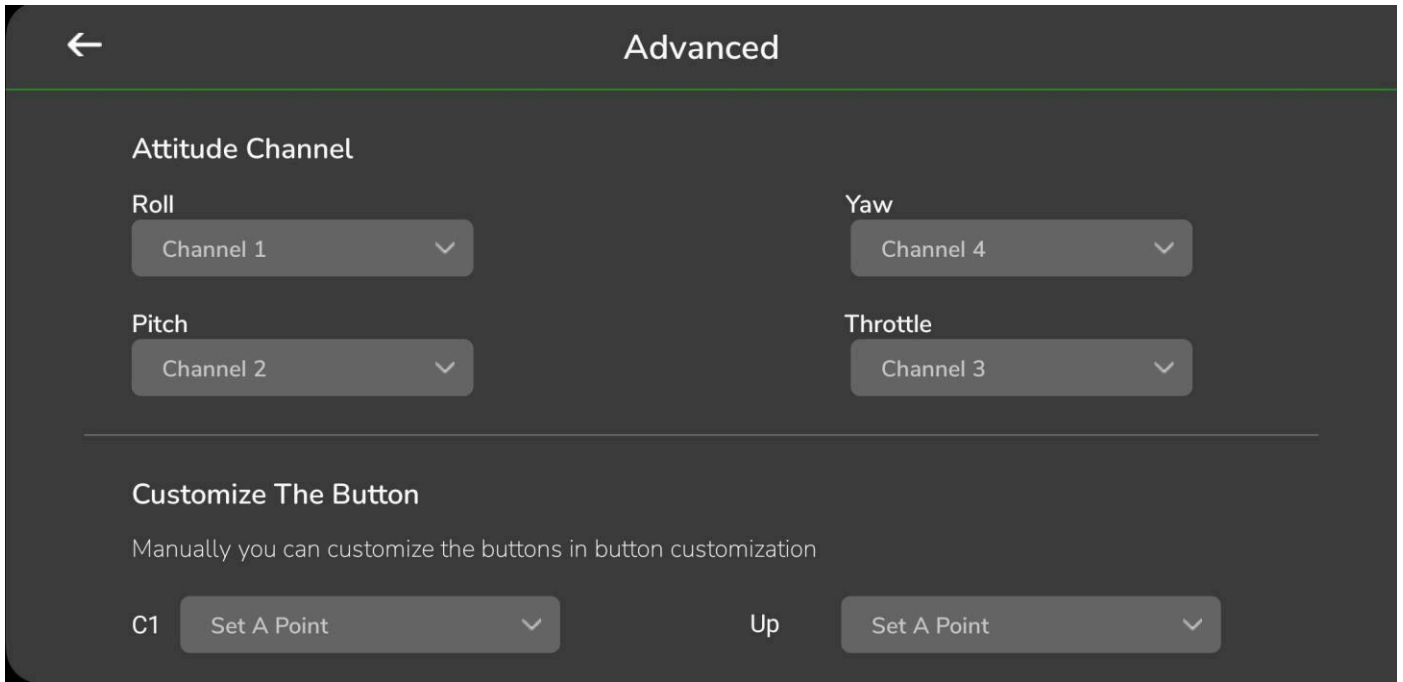

Figure 3.3.96: Advanced Settings

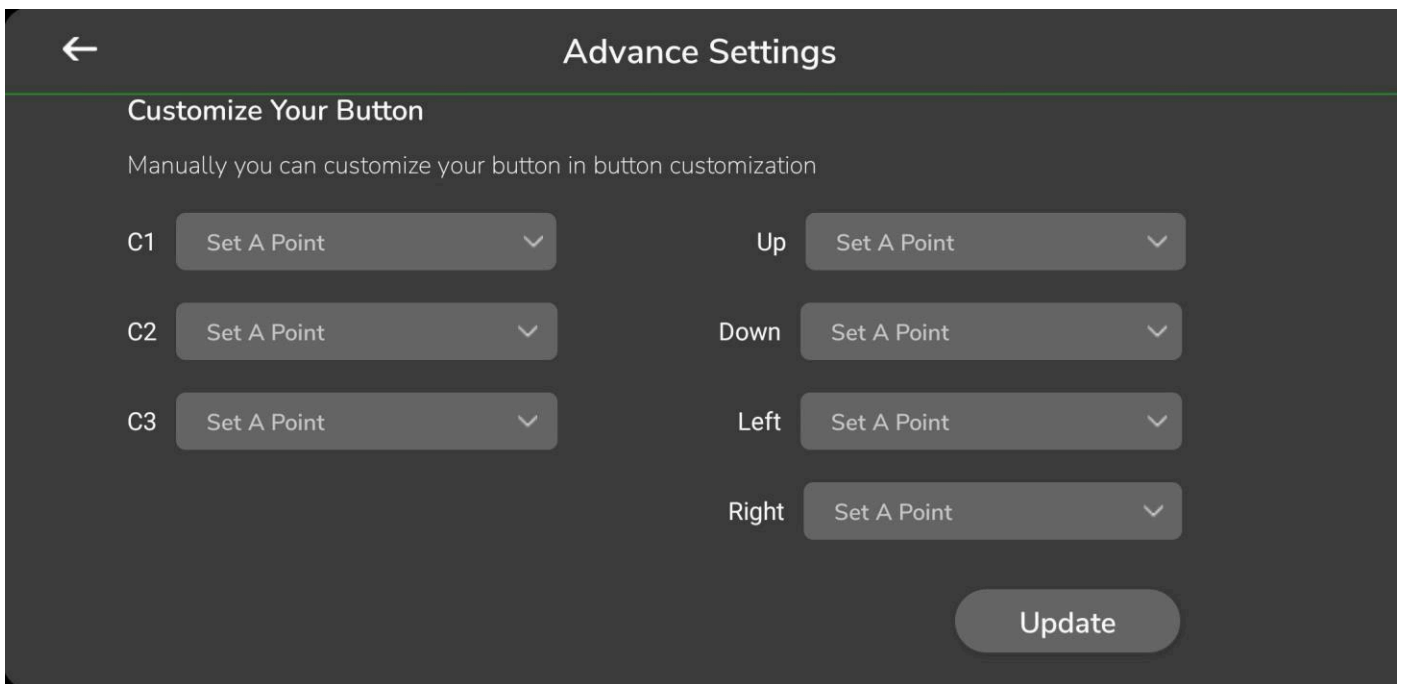

Figure 3.3.97: Advance Settings

Flight Manual			
Pavaman Aviations Private Limited			
Issue No.	09	Version No.	1.9
Date	22/07/2024	Document Reference	PA - 8

4.4.2. Compass Calibration Settings

Calibrate the compass through these settings. The gyroscope measures rotational forces. By combining these measurements, the flight controller is able to calculate the current altitude of the drone. Therefore, compass calibration is important before the flight. Click on the "Calibrate Compass" button to calibrate it. Follow all the instructions displayed on the screen for proper calibration of the compass.

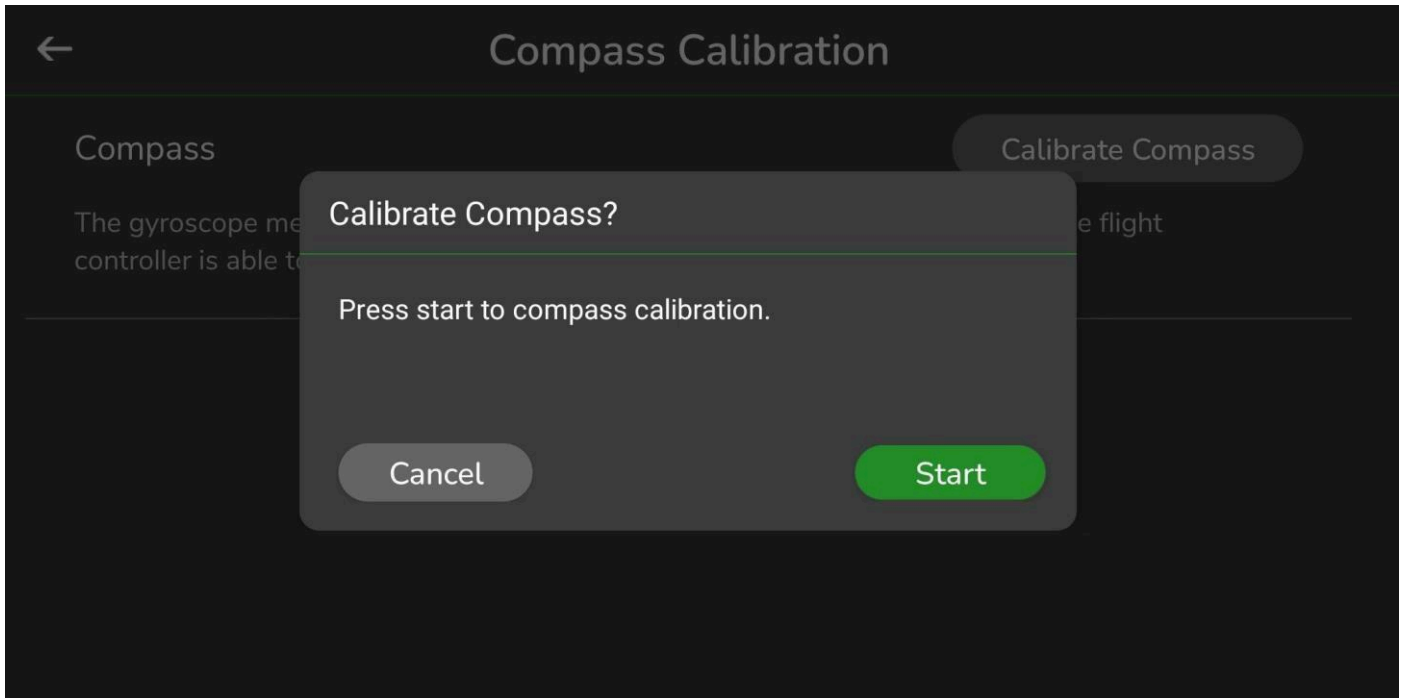

Figure 3.3.99: Calibration of Compass

Click on the "Start" button to start the procedure of calibration of compass.

Follow the instructions that popped up on the screen to complete the process of calibration of the compass.

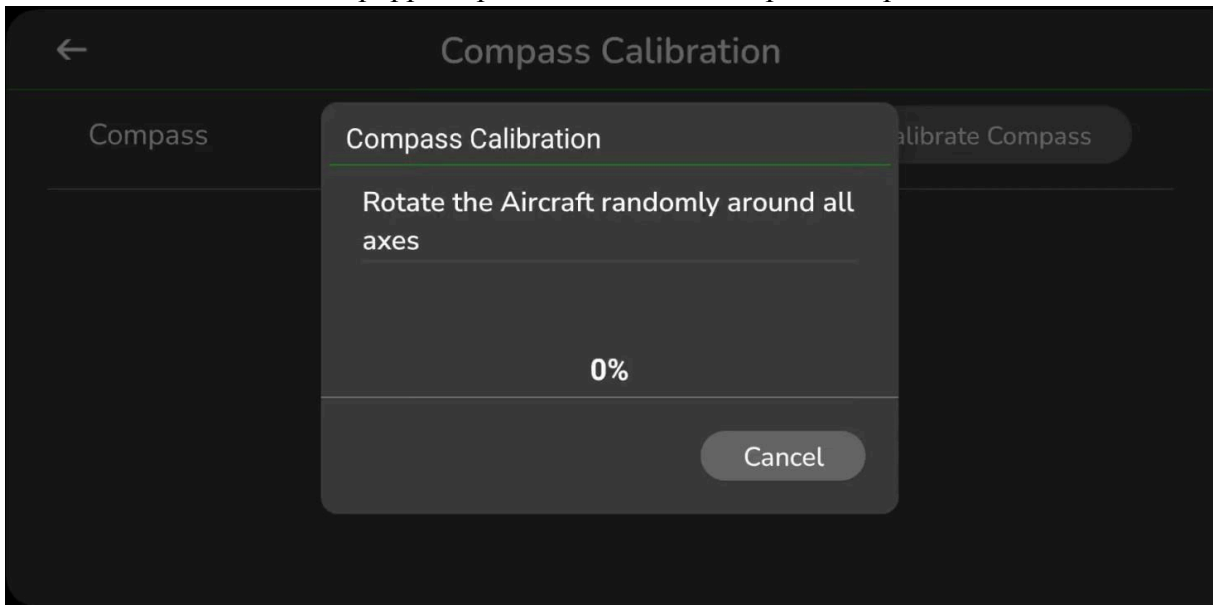

Figure 3.3.100:

Starting of Calibration of Compass

Flight Manual			
Pavaman Aviations Private Limited			
Issue No.	09	Version No.	1.9
Date	22/07/2024	Document Reference	PA - 8

After successful completion of compass calibration, the message will be displayed accordingly with 100% as a progress value.

IMU Calibration Settings

IMU is the combination of an Accelerometer, Barometer, and Level Horizon sensors. Calibration of all these sensors are done through these settings.

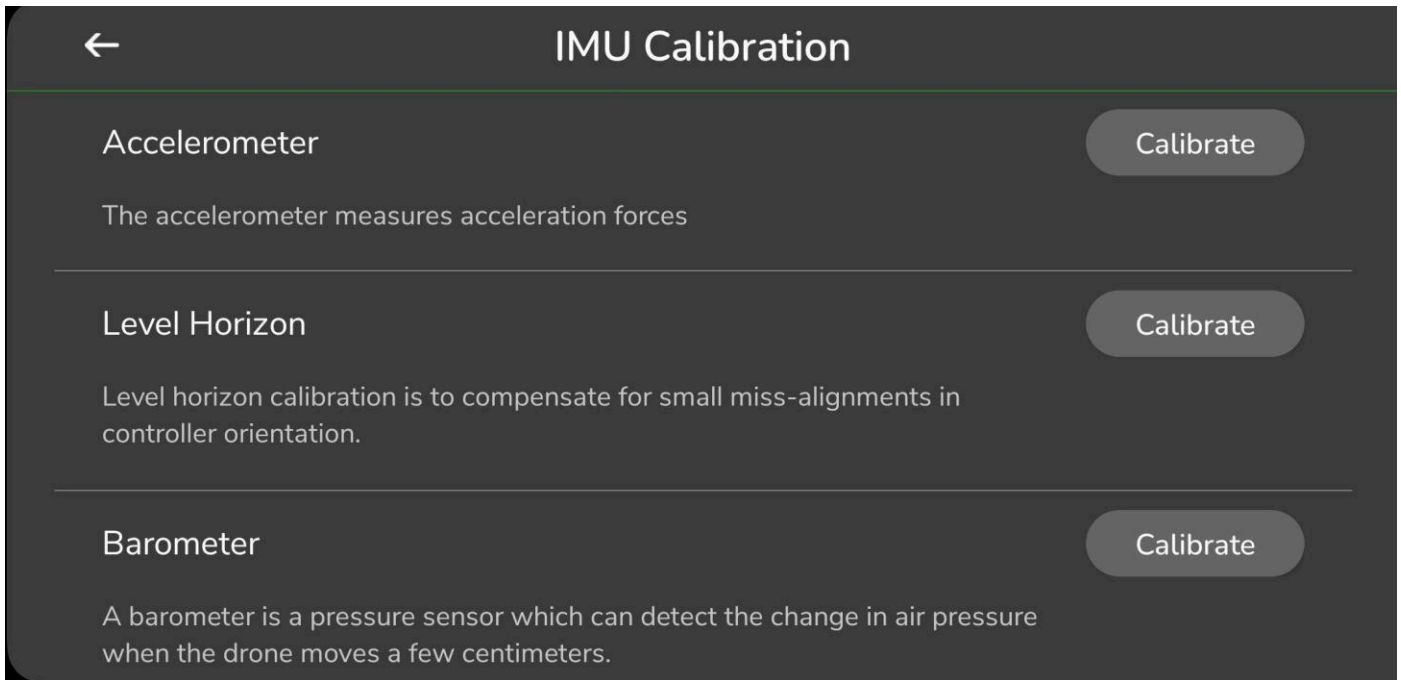

Figure 3.3.101: IMU Calibration

Accelerometer: Accelerometer measures the acceleration forces. Therefore, calibration of these sensors is a must before every flight. To calibrate the accelerometer in AeroGCS GREEN, click on the "Calibrate" button and follow the instructions displayed on the screen. When completed the process it will give an intimation regarding the completion of the calibration process

Flight Manual			
Pavaman Aviations Private Limited			
Issue No.	09	Version No.	1.9
Date	22/07/2024	Document Reference	PA - 8



Figure 3.3.102: Accelerometer Calibration

Click on the "Start" button to start the process of accelerometer calibration.

Level Horizon: This sensor helps to compensate for small misalignments in the orientation of the controller.

To get better results in terms of flight performance and efficiency of the drone, it is recommended to calibrate the level horizon before a flight. To calibrate the Level Horizon in AeroGCS GREEN, click on the 'Calibrate' button and follow the instructions that appeared on the screen to complete the calibration process.

Barometer: These sensors are also used to measure the altitude of the drone. To measure changes in pressure accurately, it is mandatory to calibrate the barometer before the flight which is established by the calibrating Barometer.

<h1>Flight Manual</h1>			
<h2>Pavaman Aviations Private Limited</h2>			
Issue No.	09	Version No.	1.9
Date	22/07/2024	Document Reference	PA - 8

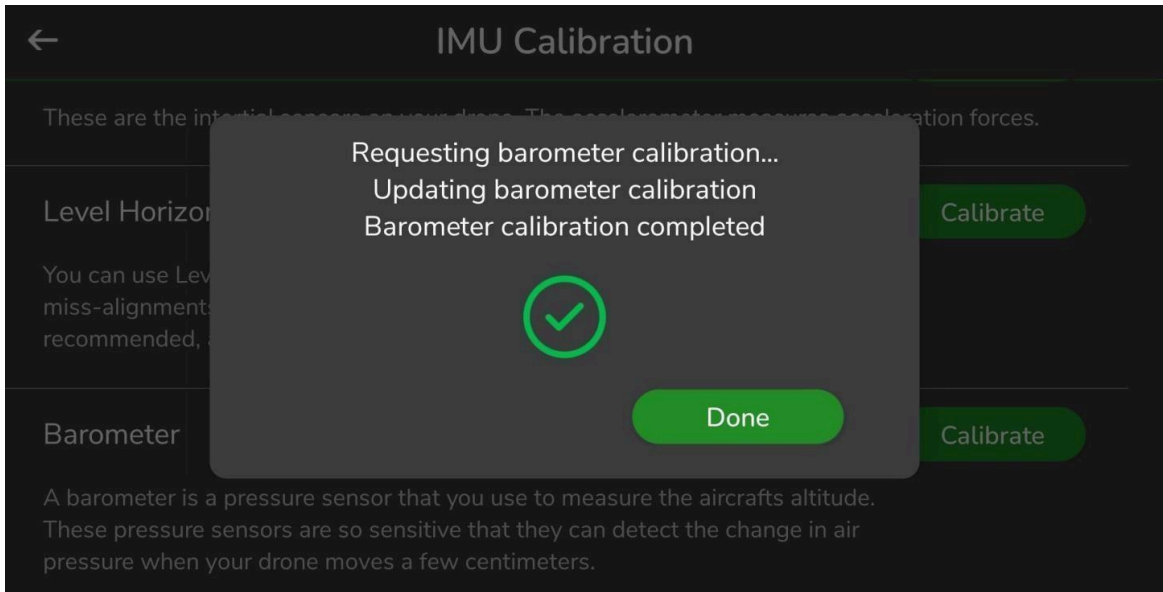

Figure 3.3.103:

Calibration of Barometer

4.5. Safety

The entire flight of a drone should be carried out in a smooth way without any disturbances. All care should be taken by a pilot before and during the flight. A few parameters are set before the flight to handle emergency situations during the flight.

All such safety actions are assigned by using this setting option. AeroGCS GREEN allows the user to set the following settings:

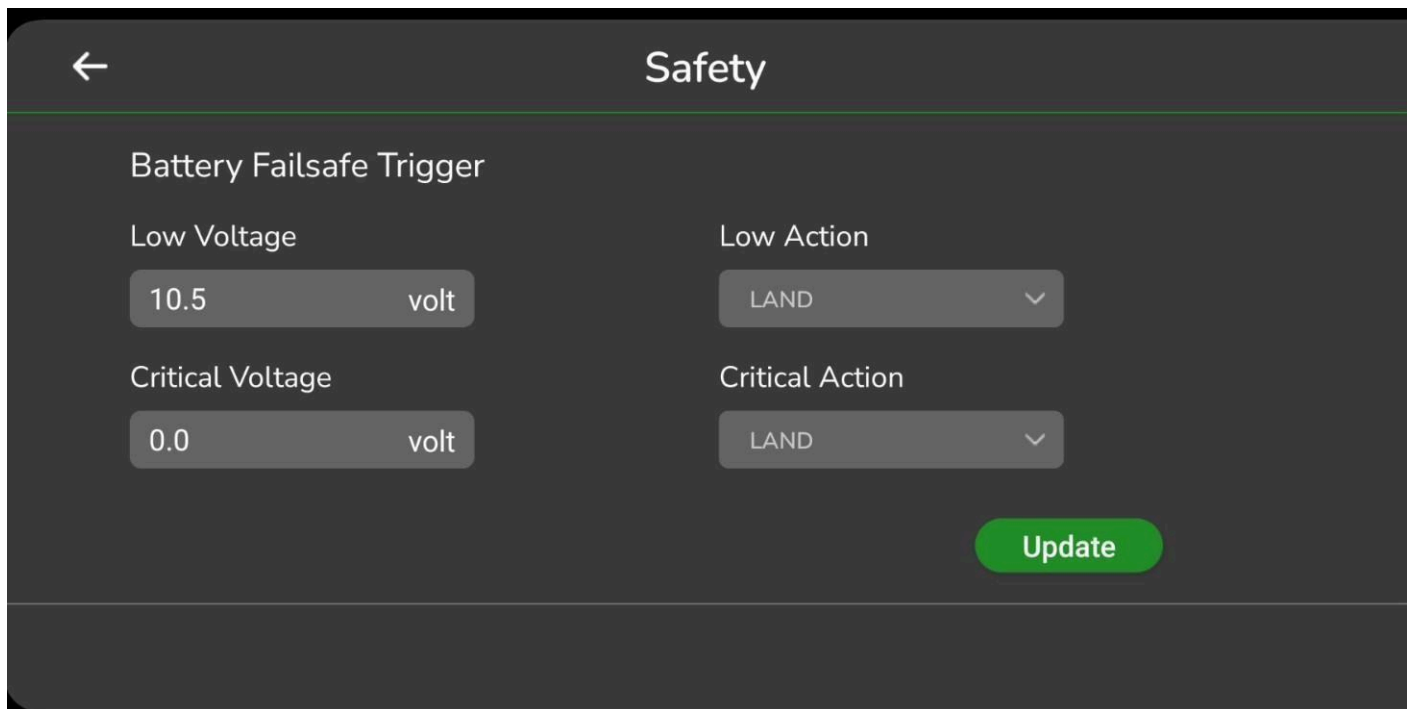

Figure 3.3.108: Safety Settings

Flight Manual			
Pavaman Aviations Private Limited			
Issue No.	09	Version No.	1.9
Date	22/07/2024	Document Reference	PA - 8

Battery Failsafe Trigger:

1. **Low Voltage:** Set the value which will be identified as a low voltage and the voltages below that value will be considered for failsafe generations.
2. **Low Action:** This option allows the user to assign the action to be performed after detecting the voltage of a battery that is below the value set in low voltage.

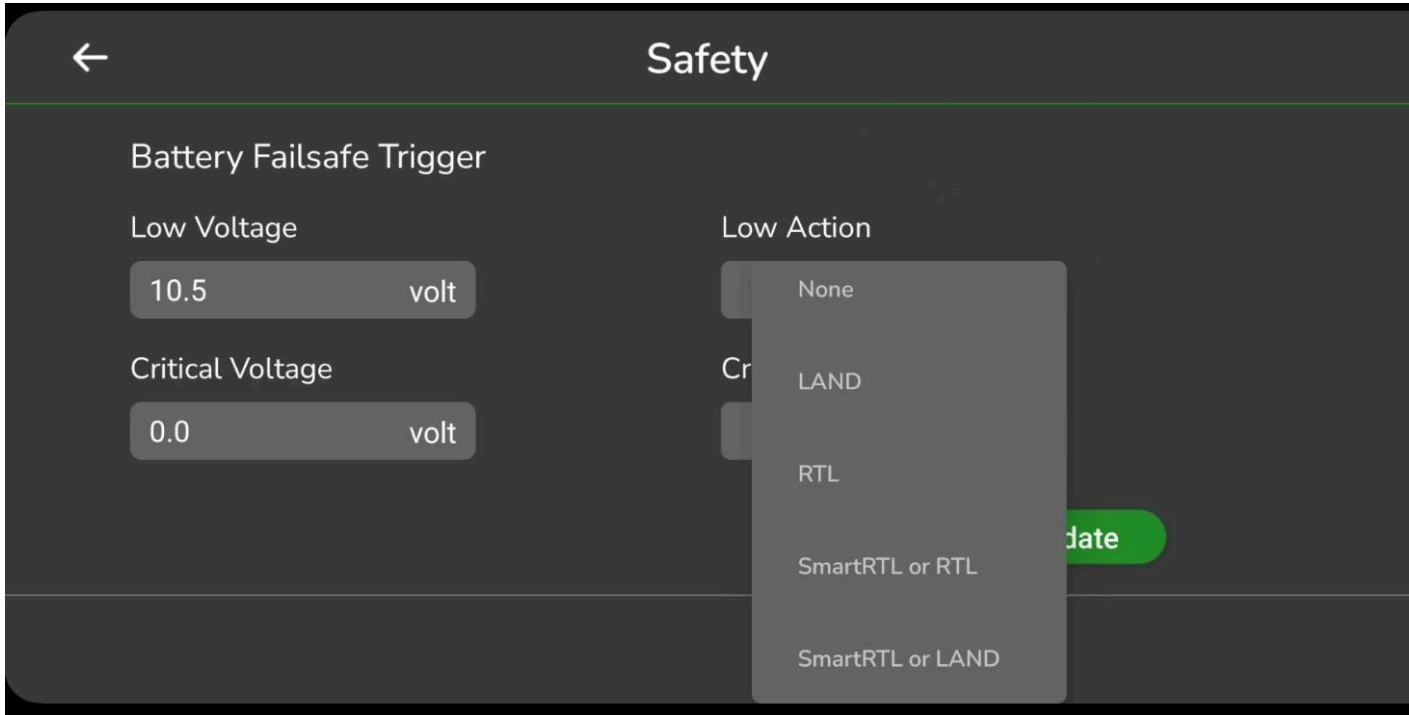

Figure 3.3.109: Setting of a Action for Low Battery Voltage

1. **Critical Voltage:** Set the critical value of voltage of battery for handling the safety of the drone.
2. **Critical Action:** Assign the action to be performed on attaining the critical voltage value.

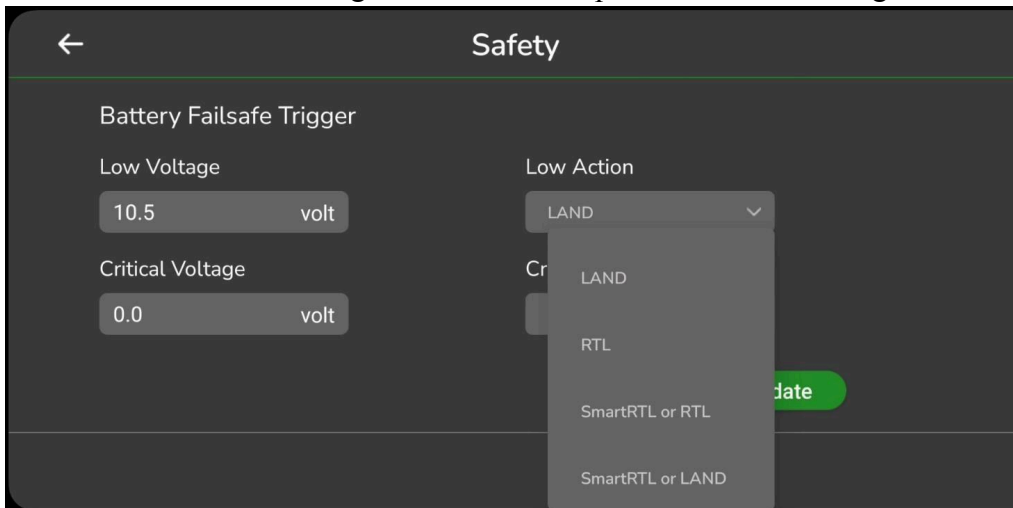

Figure 3.3.110: The setting of Action to be Taken on Critical Voltage

<h1>Flight Manual</h1>			
<h2>Pavaman Aviations Private Limited</h2>			
Issue No.	09	Version No.	1.9
Date	22/07/2024	Document Reference	PA - 8

All these settings will ensure the safety of the drone during the flight. **General Settings**

These settings allow the user to select the language and get the details of the software as shown in the image below: Choose your Language:

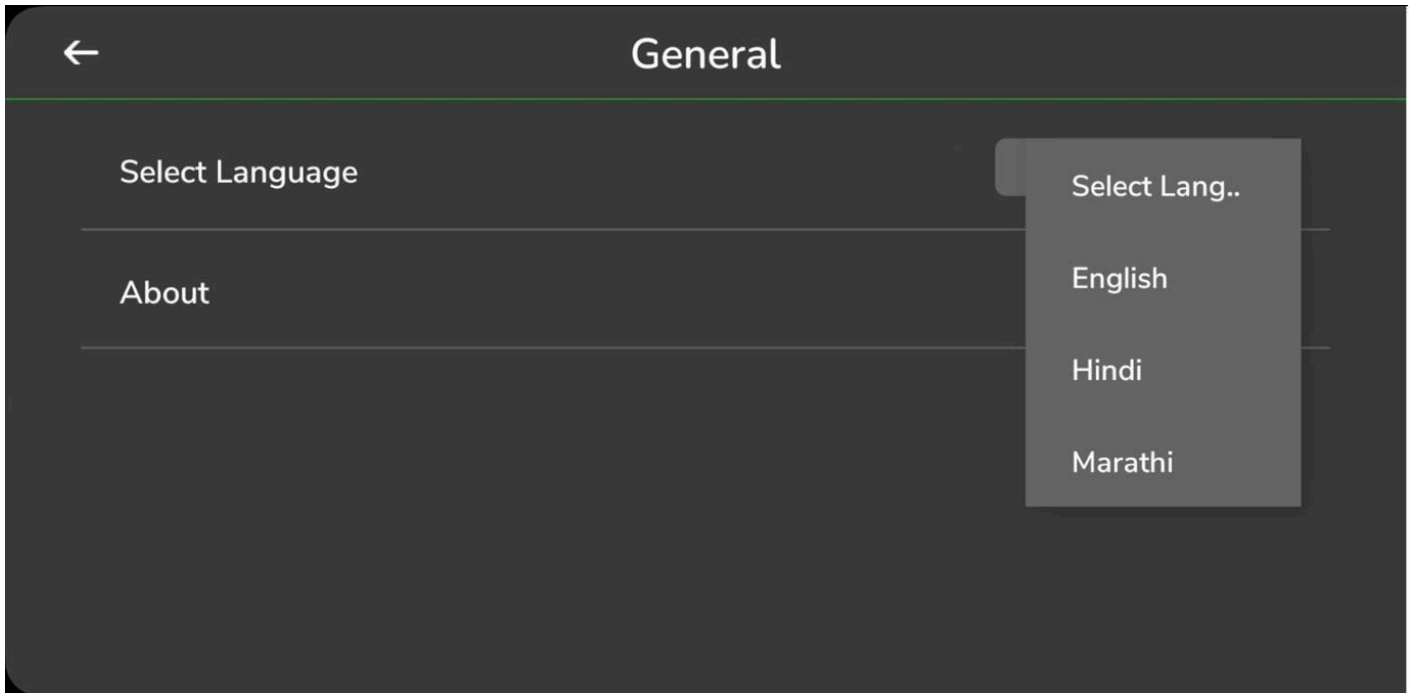

Figure 3.3.111: General Settings

Select the desired language from the drop-down menu.

About: This option will display the details of the software which you are using.



Figure3.3.112: About the Software

Flight Manual			
Pavaman Aviations Private Limited			
Issue No.	09	Version No.	1.9
Date	22/07/2024	Document Reference	PA - 8

It contains the details as follows:

App: This mentions the name of the app you are using. Here it is AeroGCS GREEN.

Version: The user is using version v1.17.49 of AeroGCS GREEN.

Build No of AeroGCS GREEN is 2023.26.05.01

The date of release for the software is mentioned here.

The information to contact us and the address of the website is also mentioned here.

This information is available in read-only mode. No modifications are allowed here.

4.6. Field Plot Functionality

Creating a plot is the first step in spraying on the field. To create a field plot, the user has to select the exact and accurate points on the field.

AeroGCS GREEN provides three different methods for field plots such as:

1. Using RC/ Mobile
2. Using Drone
3. Using Map

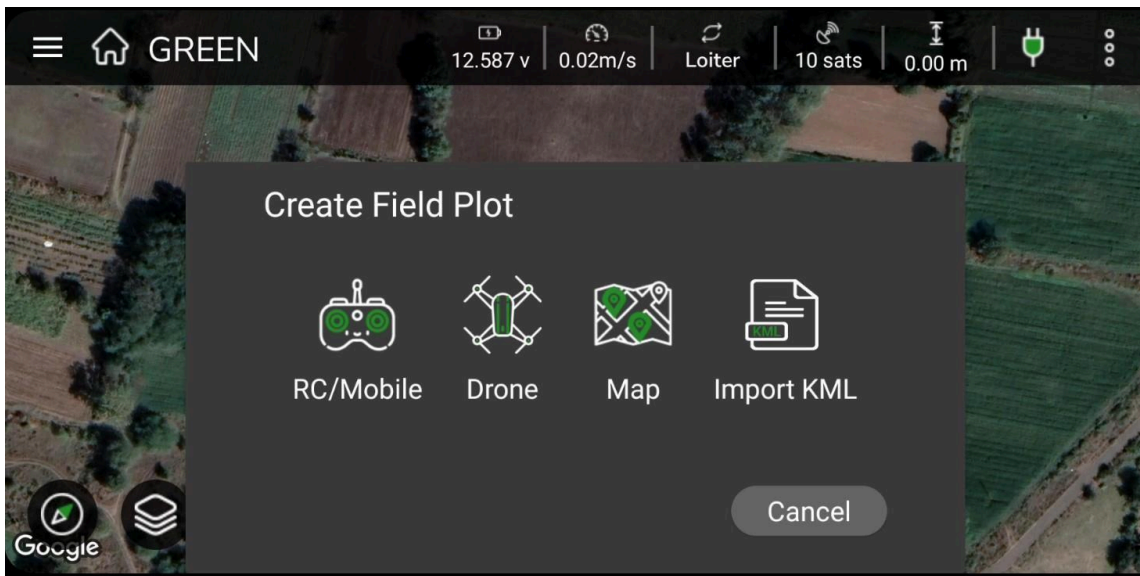

Figure 3.3.115: Field Plot Functionalities

4.7. Using RC/Mobile

In this process, the user will use the RC or Mobile to locate the boundaries of the field plot. Carry the RC or Mobile with you. Go to the exact location where you must mark the point of a boundary. Click on the "Add Point" button to add it to the field plot.

This method will give you an accurate location of the field plot.

Flight Manual			
Pavaman Aviations Private Limited			
Issue No.	09	Version No.	1.9
Date	22/07/2024	Document Reference	PA - 8

Save the plot and proceed with creating a plan. Set all the parameters as per requirements and save the plan also.

4.8. Using Drone

Sometimes, there may be some issues related to internal GPS. Due to this, the location of points may get affected and the accuracy of the field plot may get disturbed.

To avoid such situations, AeroGCS GREEN provides field plotting functionality using a drone. Fly a drone in the specified area. Hover the drone at a particular position to mark it as a point for a field plot. Click on the "Add Point" button on the AeroGCS GREEN and move further to mark other points.

Save the plot and proceed with creating a plan. Set all the parameters as per requirements and save the plan also. This procedure will enhance the accuracy of the location of the points.

4.9. Using Map

This is the standard option available to plot a field. Use Google Maps to set the location. Search a location and then set that particular location for flying a drone. Go on adding points one by one to the field plot. Save the plot and save the plan with the desired parameters as shown in the screen recording below:

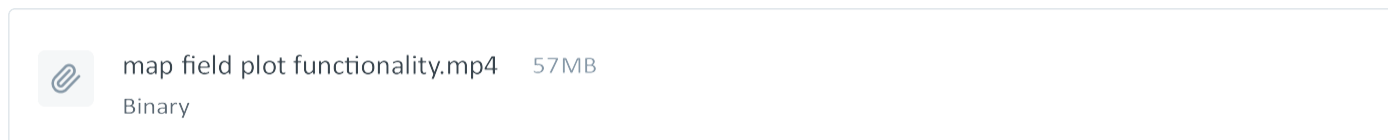

Map Field Plot Functionality

4.10. Import KML

Geographical data can be displayed in Google Earth and other apps that employ virtual globes thanks to KML (Keyhole Markup Language) files.

Large volumes of data can be displayed visually using KML files, making it simpler to comprehend and analyze the data. Multiple users can view and update the same data in Google Earth with KML files' ability to be shared and worked on collaboratively. In order to interact with data across several platforms, KML files can be readily connected with other GIS tools. KML files can be used to depict historical data, including changes in population density, land use, and other patterns over time.

Select the "Import KML" option for creating a field plot and then select the appropriate KML file saved on your system to open that specific file.

Flight Manual			
Pavaman Aviations Private Limited			
Issue No.	09	Version No.	1.9
Date	22/07/2024	Document Reference	PA - 8

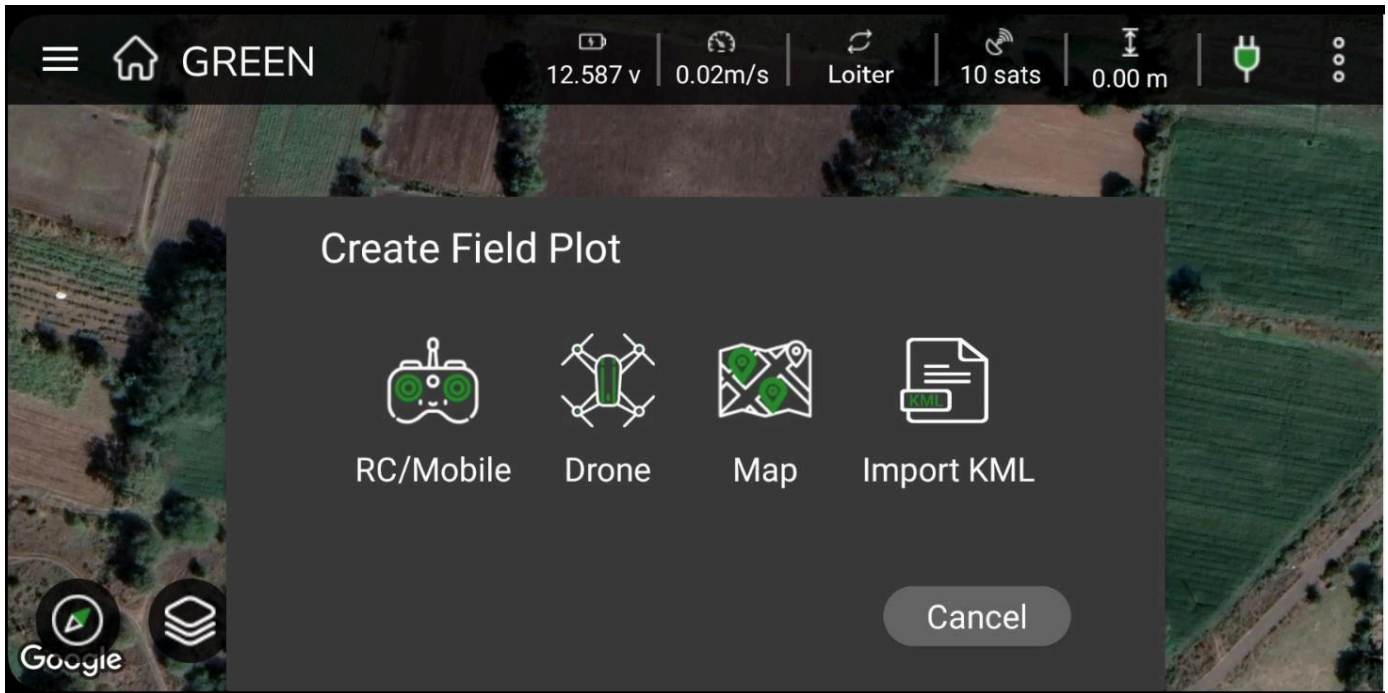



Figure 3.3.116: Creating a Field Plot by Importing KML

A spraying plan will be created with the selected KML file. Start using it for spraying with the appropriate settings of parameters.

4.11. Mission Planning Functionality

4.11.1. Parameters

Setting the parameters is very important in flying a drone. The user can set the parameters by clicking on  the button on the dashboard or the options popped up on the left-hand side of the screen after creating a plan.

The list of parameters supported by AeroGCS GREEN are as follows:

<h1>Flight Manual</h1>			
<h2>Pavaman Aviations Private Limited</h2>			
Issue No.	09	Version No.	1.9
Date	22/07/2024	Document Reference	PA - 8

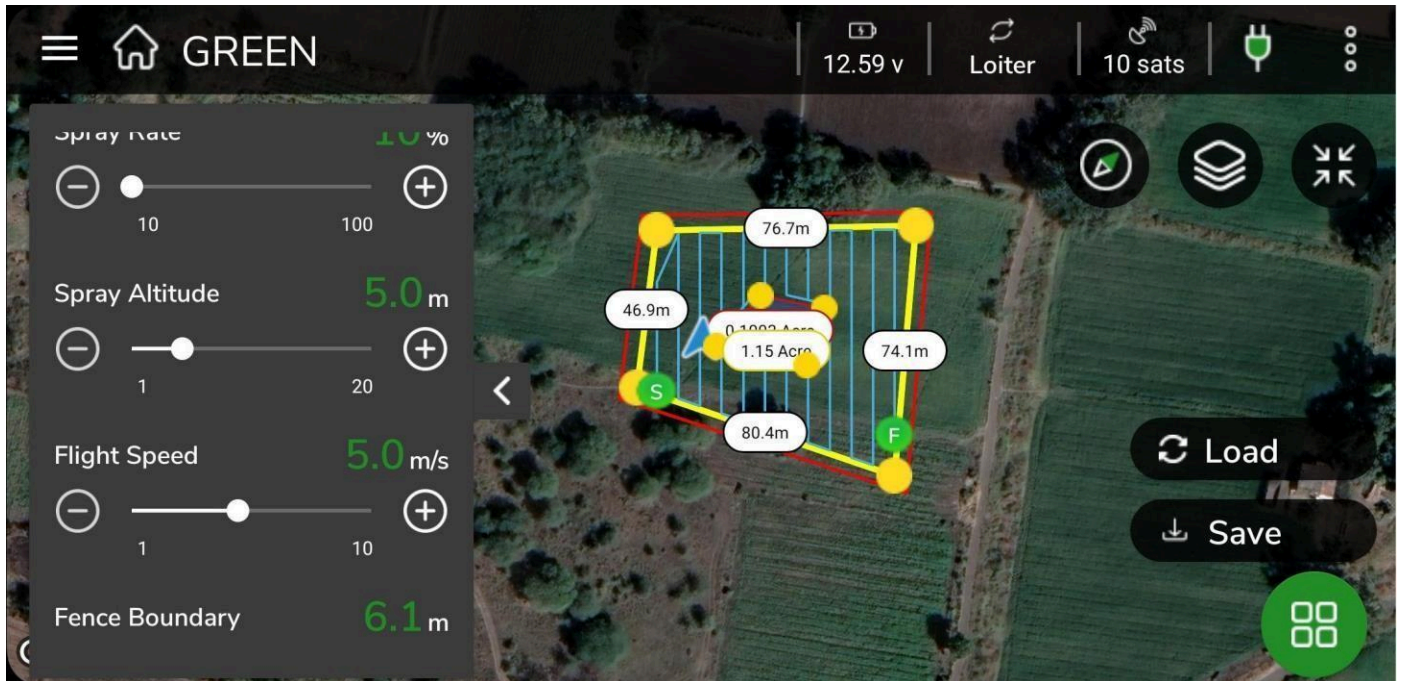
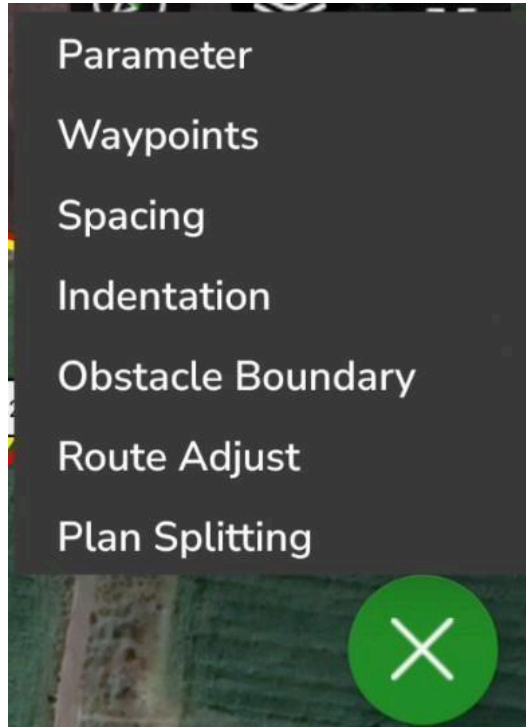

Figure 3.3.117: Setting Parameters

Flight Manual			
Pavaman Aviations Private Limited			
Issue No.	09	Version No.	1.9
Date	22/07/2024	Document Reference	PA - 8

AeroGCS GREEN will provide the list of parameters to set at the desired values. The values are set just by changing the positions of slide bar from the screen. Different parameters can be set such as:

Spray amount: decides the amount of the spraying the liquid in L/Acre. Spray amount can be set from minimum 1 L/Acre to maximum 50 L/Acre

Spray rate: Decides the rate of spraying from minimum 10 % to maximum of 100%.

Spray altitude: set the altitude of Spraying from minimum of 1 m to maximum of 15 m.

Flight Speed: The user can set the flight speed from a minimum of 1 m/s to 10 m/s.

Spacing: This option allows to change the spacing between the polylines of the plan. The user can set the spacing from minimum of 2 m to maximum of 10 m.

Fence boundary: Fence boundary can be adjusted from 1 m to 10 m to safeguard the device.

4.11.2. Adjust Waypoint

AeroGCS GREEN allows the user to adjust the waypoints according to the requirement to get better results and better accuracy, and efficiency.

Click on the  button to select "Waypoints" as shown in the following image to adjust the waypoints.

The 'Adjust Waypoints' screen will pop up on the screen's left side. Select a waypoint that you want to adjust. After getting selected, the color of the waypoint changed to Green from yellow. Adjust the location of the waypoint with the arrows present on the screen. After adjusting the waypoint, press on the Ok button. The changes will be stored.



Figure 3.3.118: adjusting Waypoints

Flight Manual			
Pavaman Aviations Private Limited			
Issue No.	09	Version No.	1.9
Date	22/07/2024	Document Reference	PA - 8

4.11.3. Adjust Spacing

Click on the  button to select "Spacing" as shown in the following image to adjust the spacing between the rows of the plan.

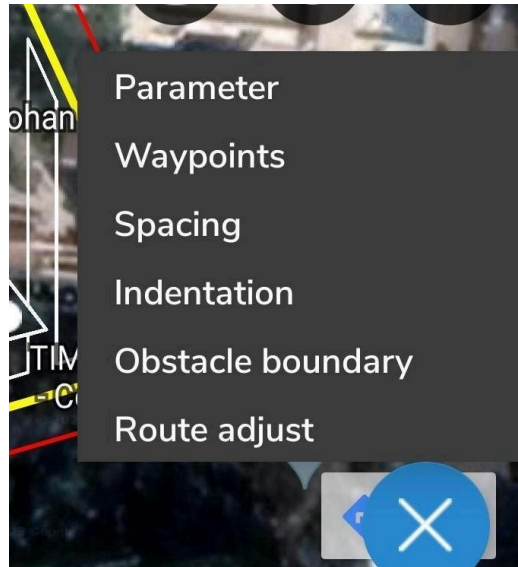

Figure 3.3.119: Parameters

Just changing the position of the slide bar, the user can change the spacing between the rows of the plan. The minimum spacing allowed is 2 m and the maximum spacing is 10 m.

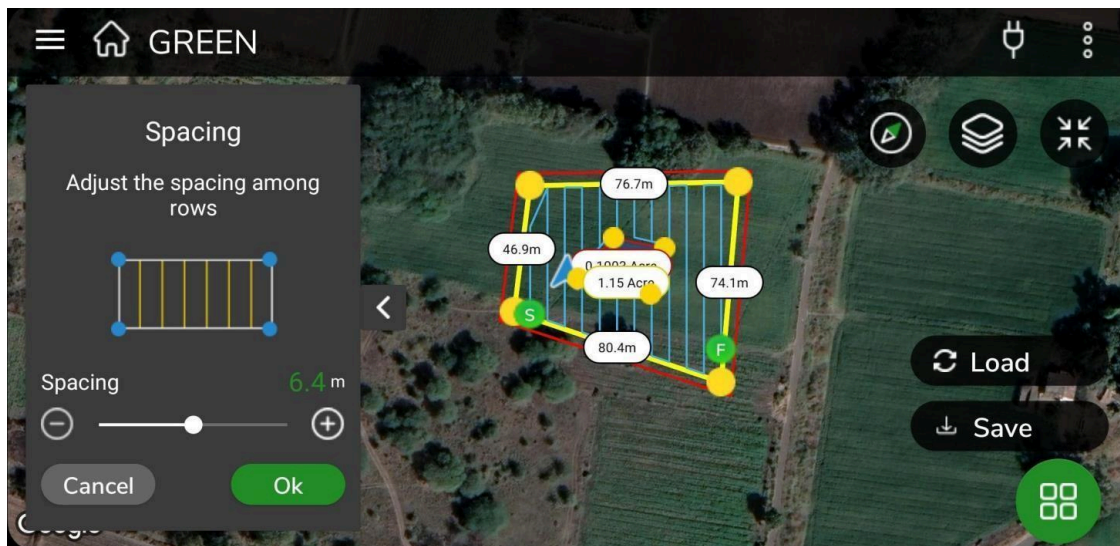



Figure 3.3.120: Adjust Spacing

After adjusting the spacing press the 'Ok' button.

Flight Manual			
Pavaman Aviations Private Limited			
Issue No.	09	Version No.	1.9
Date	22/07/2024	Document Reference	PA - 8

4.11.4. Indentation

Click on the  button to select "Indentation" as shown in the following image to adjust the indentation of the plan.

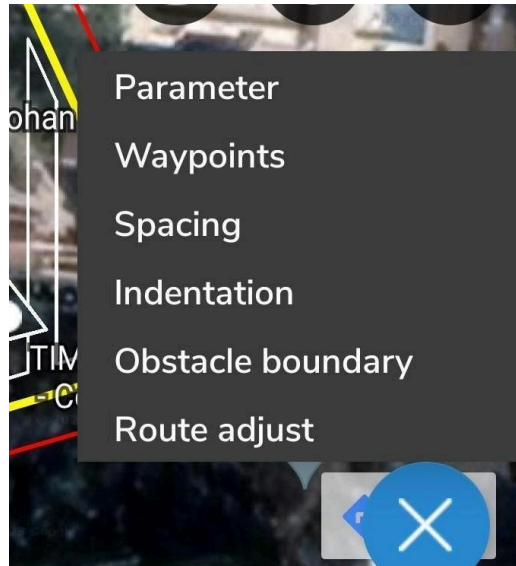

Figure 3.3.121: Parameters

Select the edge or side of the plan to adjust the indentation. The color of the selected edge will turn Green as shown in the following image. The user can set the indentation from 1 to 10 m.



Figure 3.3.122: Indentation

<h1>Flight Manual</h1>			
<h2>Pavaman Aviations Private Limited</h2>			
Issue No.	09	Version No.	1.9
Date	22/07/2024	Document Reference	PA - 8

This type of adjustment makes sure that the spraying happens only in the required field and not in the neighbouring field.

4.11.5. Adjust Route

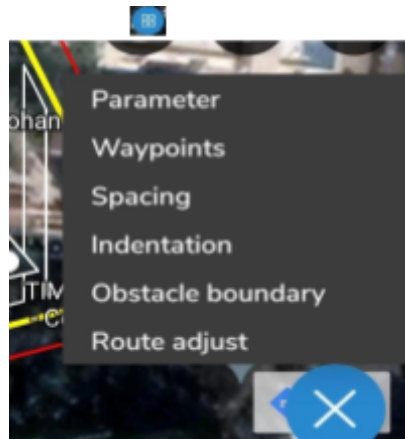

Figure 3.3.125: Route Adjust

Click on the button to select "Route adjust" as shown in the following image to adjust the route on the plan.

After selecting 'Route adjust', the following popup will be shown on the screen. By using the slide bar, the angle can be adjusted from 0 degrees to 360 degrees. It will change the orientation of the rows on the plan.



Figure 3.3.126: Adjusting a Route

Select 'Ok' to save the changes done and proceed for the flight.

Flight Manual			
Pavaman Aviations Private Limited			
Issue No.	09	Version No.	1.9
Date	22/07/2024	Document Reference	PA - 8

 This icon is used to centralize the plan on the screen in case it has moved out of the screen.

4.12. Flyview

Flyview of AeroGCS GREEN gives details of the flight as shown in the following image.



Figure 3.3.153: Flyview with Project Name

The flyview shows the name of the project to which it is associated in the scrolling bar as shown in the above image.

Flight Manual			
Pavaman Aviations Private Limited			
Issue No.	09	Version No.	1.9
Date	22/07/2024	Document Reference	PA - 8



Figure 3.3.154: Flyview with Plan name

The flyview shows the name of a plan to which it is associated in the scrolling bar as shown in the above image.

1. On the left-hand side of the screen, the user will find the buttons that are required to control the flight such as:

Take-off : To fly the drone, the user should click this button. After selecting this button, the pre-flight checking will be done automatically. AeroGCS GREEN allows the user to change Speed, Altitude and spray volume here also as shown in the image below.

Flight Manual			
Pavaman Aviations Private Limited			
Issue No.	09	Version No.	1.9
Date	22/07/2024	Document Reference	PA - 8

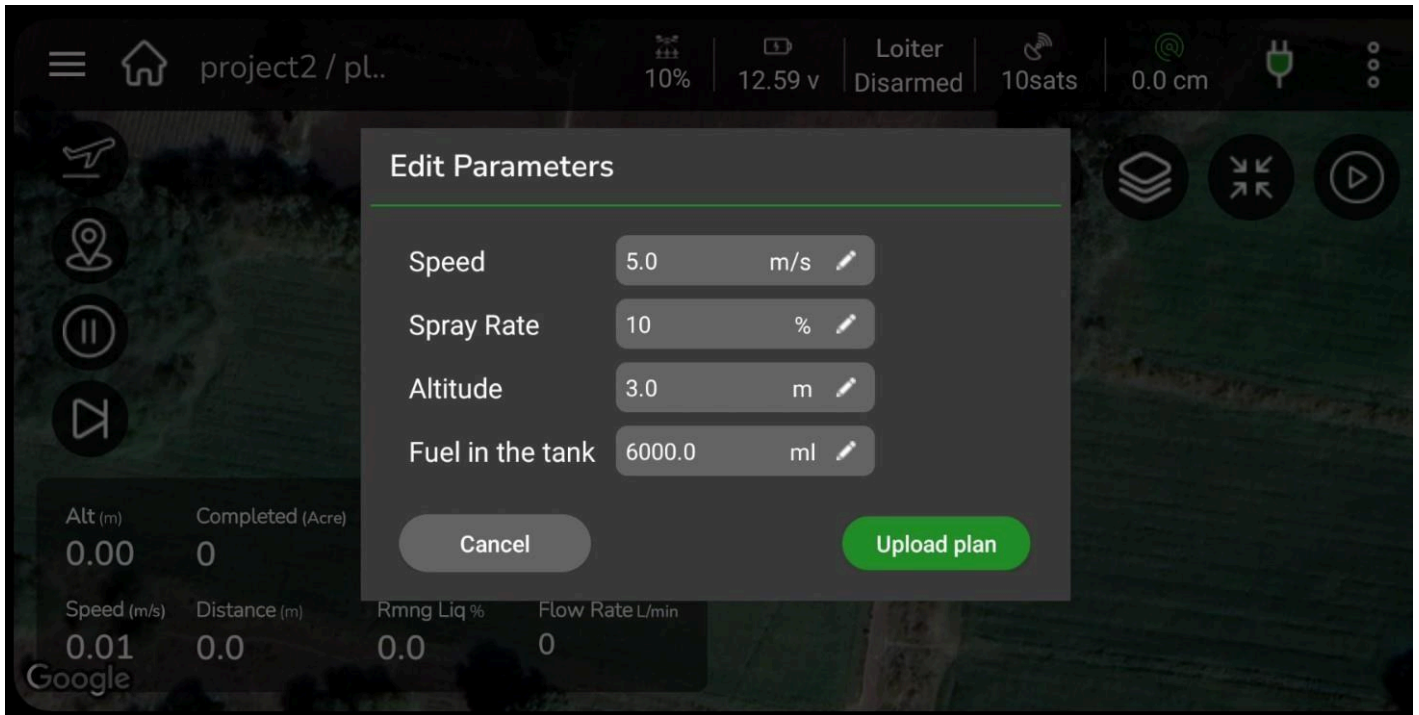

Figure 3.3.155: Edit Parameters before actual Flight

After editing these parameters, upload the plan and proceed for flying. After adjusting these parameters, flight prechecks will be performed automatically which is indicated by the popup window as shown:

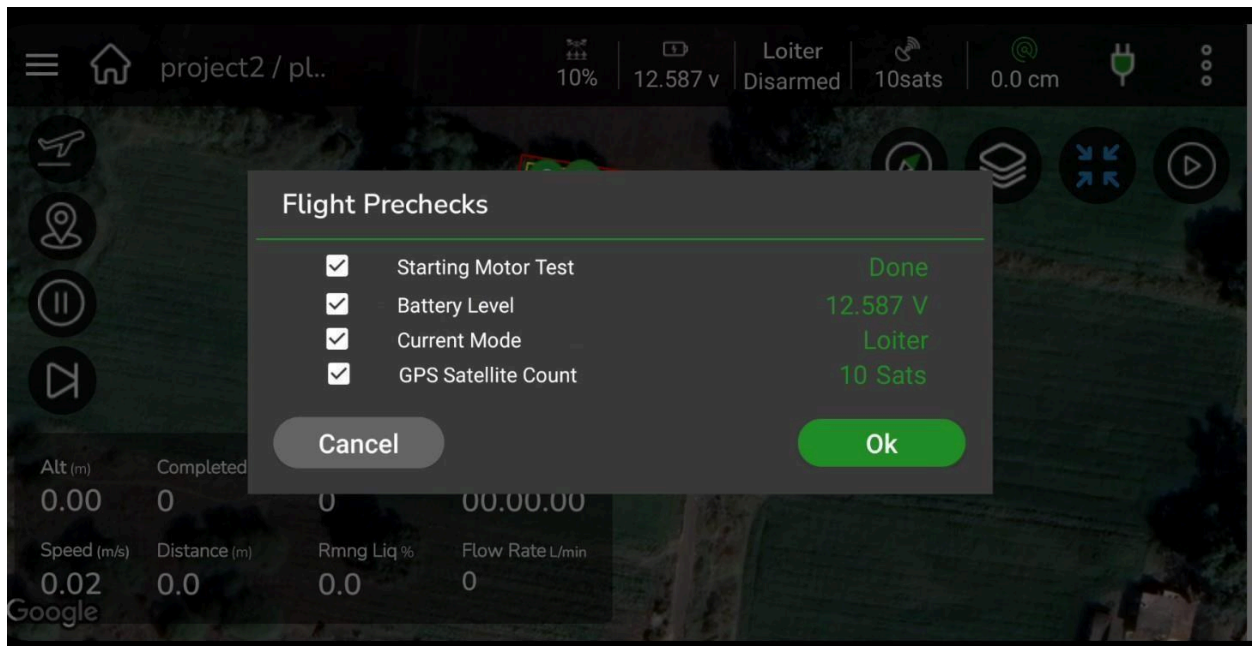

Figure 3.3.156: Flight Prechecks

Flight Manual			
Pavaman Aviations Private Limited			
Issue No.	09	Version No.	1.9
Date	22/07/2024	Document Reference	PA - 8

During flight checks, Motor test will be conducted along with a battery level check, current mode of the device, and GPS Satellite Count will be checked. On successful checks of all these, the drone will get ready to fly. Wait till all the prechecks are performed and indicated by ticks in all the checkboxes. Press ok to proceed with a flight.

To start the flight swipe  this symbol to right.

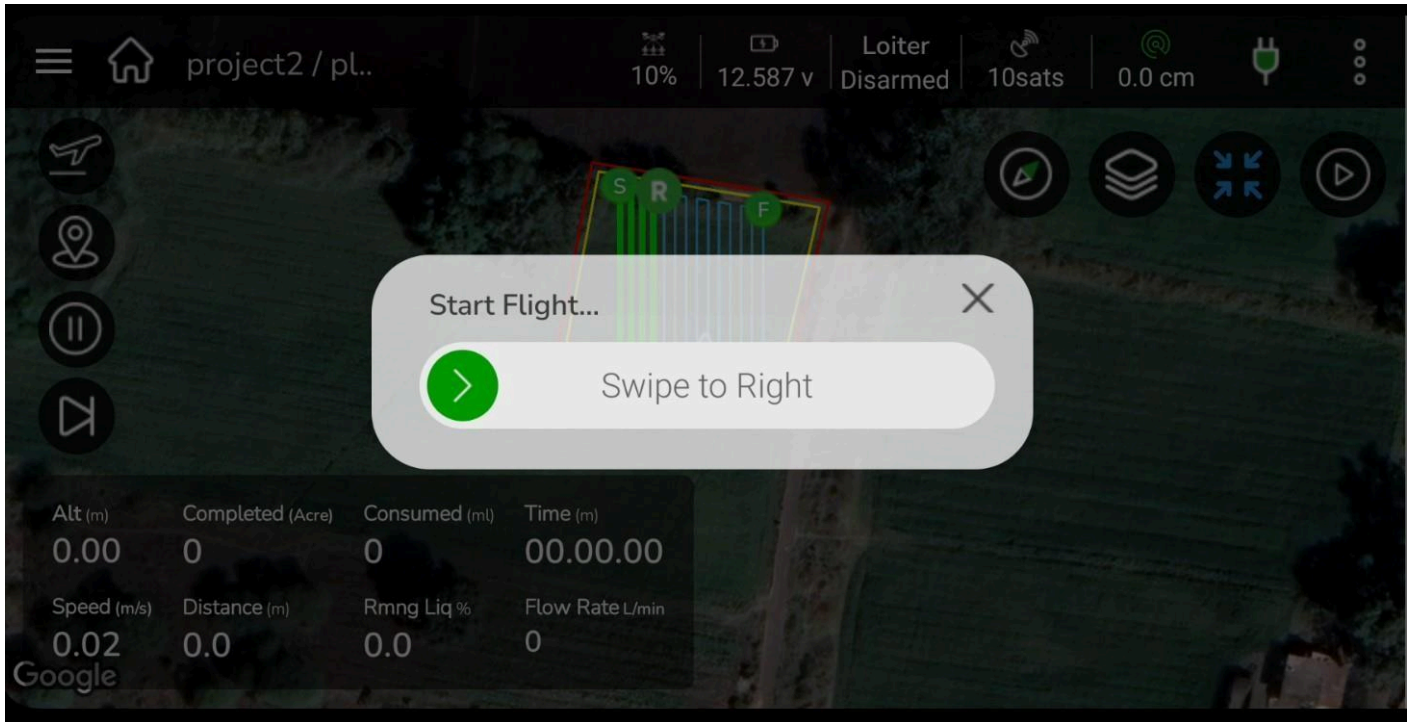



Figure 3.3.157: Start a Flight

The flight will start with raising the altitude to the desired value. The drone will be set with the defined speed at the predefined altitude.

RTL : Return to Launch: This option allows the user to terminate the flight before completing the mission in case of an emergency and return to the launch position. This symbol is used as a safe landing to the launch position. The drone will automatically return to the launch position when this option is selected. Pause : This option will allow pausing the mission of flying due to some unavoidable circumstances.

The position is marked as 'R' as shown in the image below which will be used for further process.

The drone will be landed safely at that position.

Flight Manual			
Pavaman Aviations Private Limited			
Issue No.	09	Version No.	1.9
Date	22/07/2024	Document Reference	PA - 8



Figure 3.3.159: Mission Paused

Resume : This option will allow the user to resume the earlier flight from the previous point marked as 'R' on the plan. This will help to reduce the distance to be travelled by the drone and avoid the repetition of the mission plan. If the user selects the 'Edit' option, then this resume remark will be erased and the mission will start from the starting position again which will increase the time and repetition of spraying on the same area.

Flight Manual			
Pavaman Aviations Private Limited			
Issue No.	09	Version No.	1.9
Date	22/07/2024	Document Reference	PA - 8



Figure 3.3.160: Resumed Flight

During the flight, the user can observe the following:

- changes in the altitude in meters
- current speed of a drone in meters/second
- completed area in Acres
- distance traveled by a drone in meters
- consumed amount of pesticide in mili-liter
- percentage of remaining liquid is also displayed on the flyview
- total time required to complete a mission plan

At the bottom left corner details of the flight are displayed as shown in the image below:

Alt (m)	Completed (Acre)	Consumed (ml)	Time (m)
3.00	0.164	0	00:01:02
Speed (m/s)	Distance (m)	Rmng Liq %	Flow Rate L/min
4.60	331.2m	0.0	0

Figure 3.3.161: Details of flight

Flight Manual			
Pavaman Aviations Private Limited			
Issue No.	09	Version No.	1.9
Date	22/07/2024	Document Reference	PA - 8

4.13. Dosage Calculation:

The flyview gives the calculation of dosage of liquid. It always shows the values of the consumed amount of liquid in milli- liters and the percentage of remaining liquid on the bottom left part of the screen as shown in the image. This will be helpful to control the flight and spraying liquid. The AeroGCS GREEN provides a facility for changing spraying speed during the flight from the flyview as shown in image.

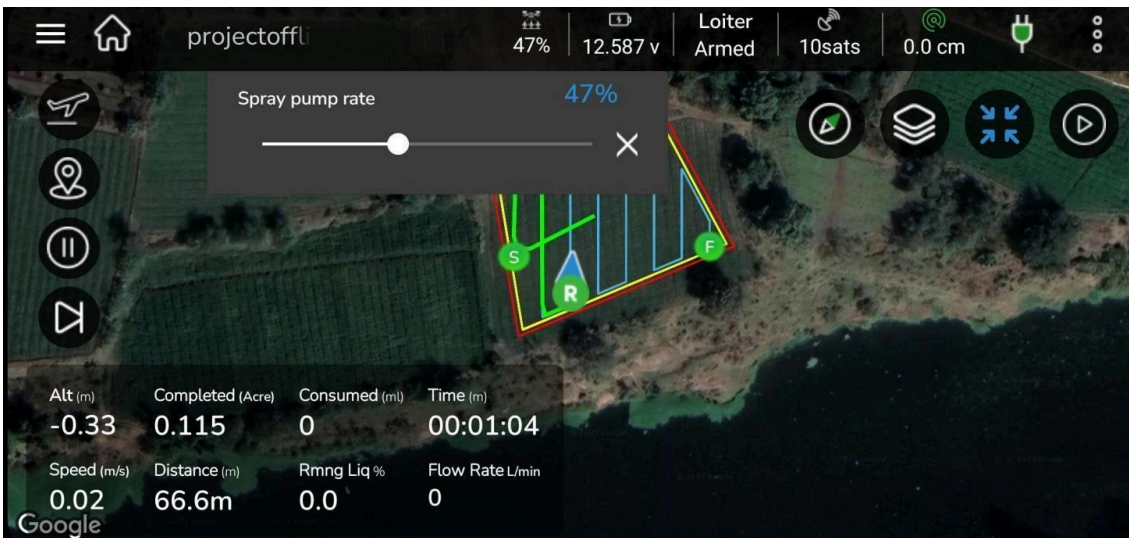

Figure 3.3.162: Adjusting Spray Pump Rate during Flight



Figure 3.3.163: Dosage Calculations

Flight Manual			
Pavaman Aviations Private Limited			
Issue No.	09	Version No.	1.9
Date	22/07/2024	Document Reference	PA - 8

The user will be able to adjust spray pump rate during the flight so as to utilize the liquid properly. Equal and efficient spraying is possible by using these two powerful features of AeroGCS GREEN.

2. The right-hand top corner of flyview looks like:

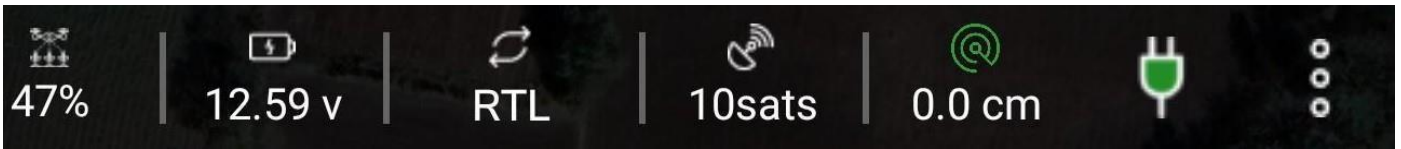





Figure 3.3.164: Flyview

The right-hand top corner shows the values related to:

Pump Rate : the value of pump rate can be changed by using a slide bar during the flight also. This indicates the spraying rate. The pump rate is always considered in percentage. This pump rate can be adjusted during the flight. This will be helpful to adjust the volume of spraying depending on the requirements of the crop.

Status of a battery : Battery voltage is continuously displayed so that the user can monitor and take corrective action if it drops below the threshold value.

Mode of operation of a drone : Drone can be operated in different modes like auto, guided, loiter, hover, RTL, etc. The current mode of operation of a drone is displayed here.

Number of Active Satellites : Active satellites are required for maintaining the connection between the drone and GCS through GPS. The number of active satellites confirms the better connectivity between the drone and GCS.

- **Connect a Drone** : This symbol shows whether a drone is connected or disconnected. If the drone is disconnected then no mission plan will be executed. The color of this symbol will be Green if it is connected otherwise it will be transparent.

Flight Manual			
Pavaman Aviations Private Limited			
Issue No.	09	Version No.	1.9
Date	22/07/2024	Document Reference	PA - 8

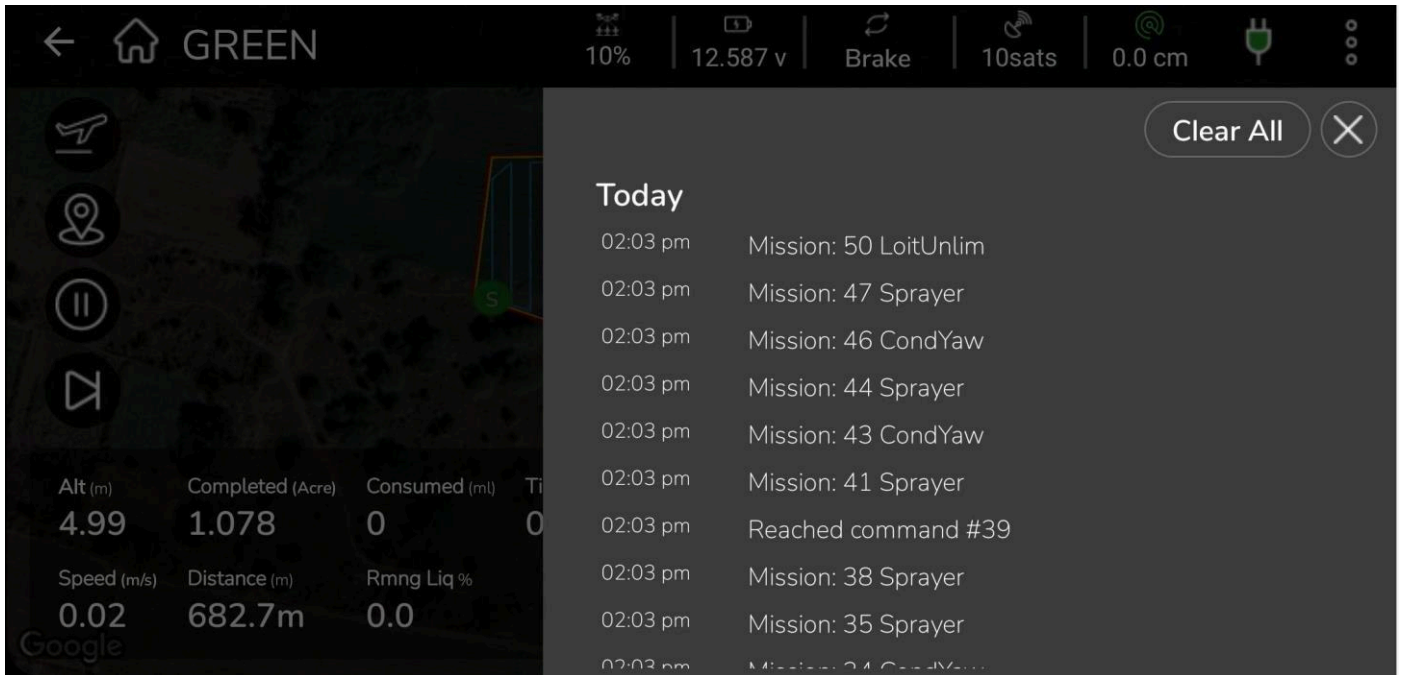

Figure 3.3.171: Notifications from Flyview

Notification: By selecting it, notifications will be displayed as shown in the image below: If the user wants to delete all the notifications, then just click on "Clear All" button. The confirmation message will pop up on the screen.

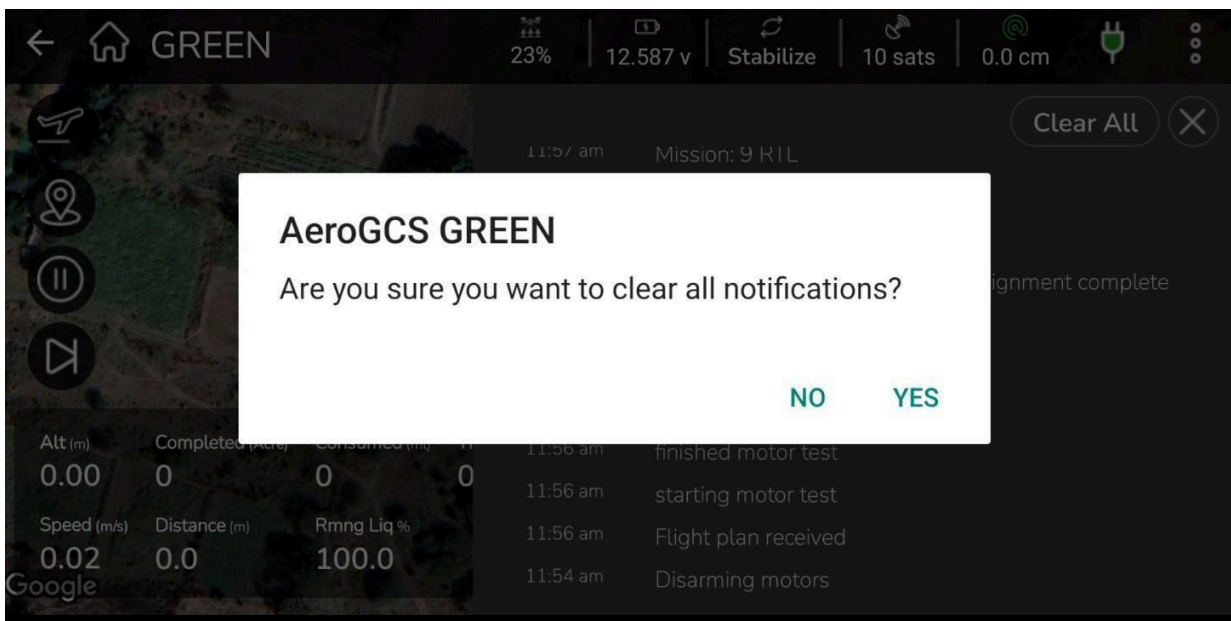

Figure 3.3.172: Confirmation of deletion of Notifications

All the notifications will be deleted after confirming the process.

<h1>Flight Manual</h1>			
<h2>Pavaman Aviations Private Limited</h2>			
Issue No.	09	Version No.	1.9
Date	22/07/2024	Document Reference	PA - 8

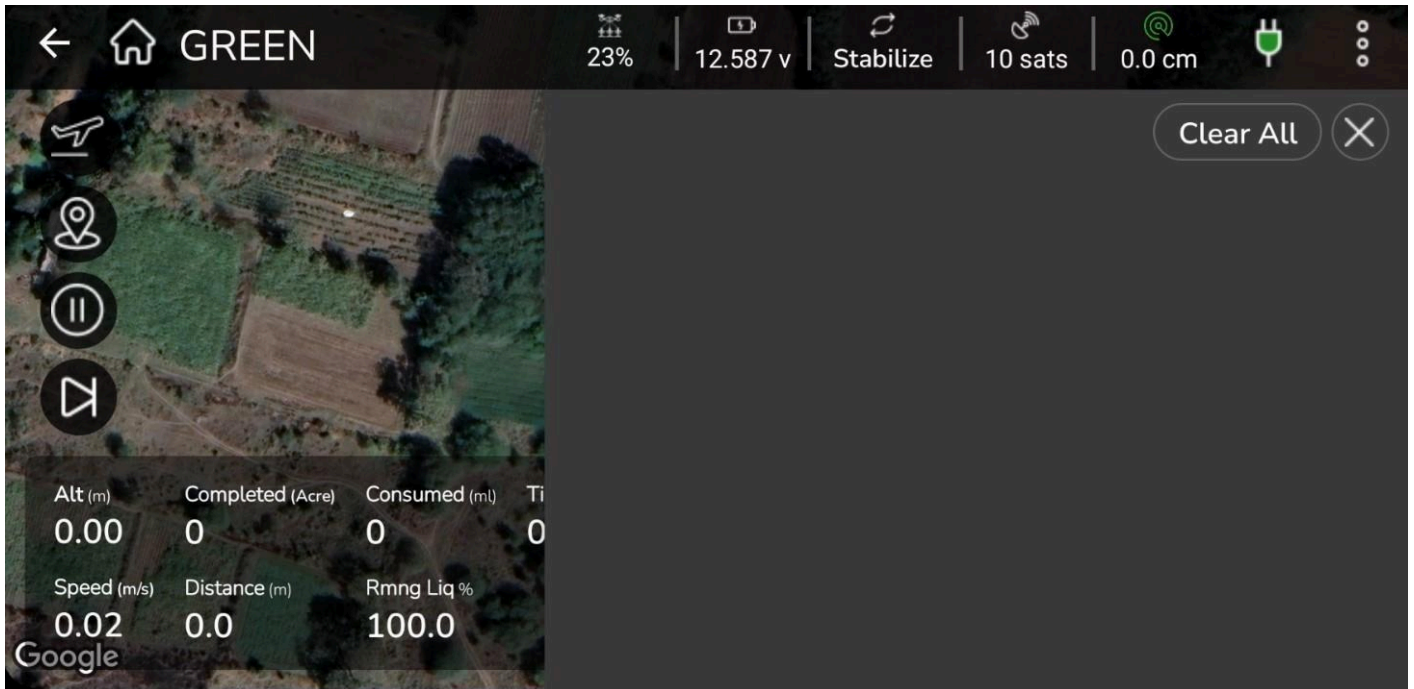

Figure 3.3.173: All Notifications are cleared

Settings: RPA Settings will be opened upon selecting this option. This option will allow the user to open, see and adjust RPA settings from flyview quickly.

Arm and Disarm Navigation Bar

This is specially designed to have a manual flight. This navigation will be displayed on the screen after the selection of a manual flight.

Select the flying method as manual from the options as shown

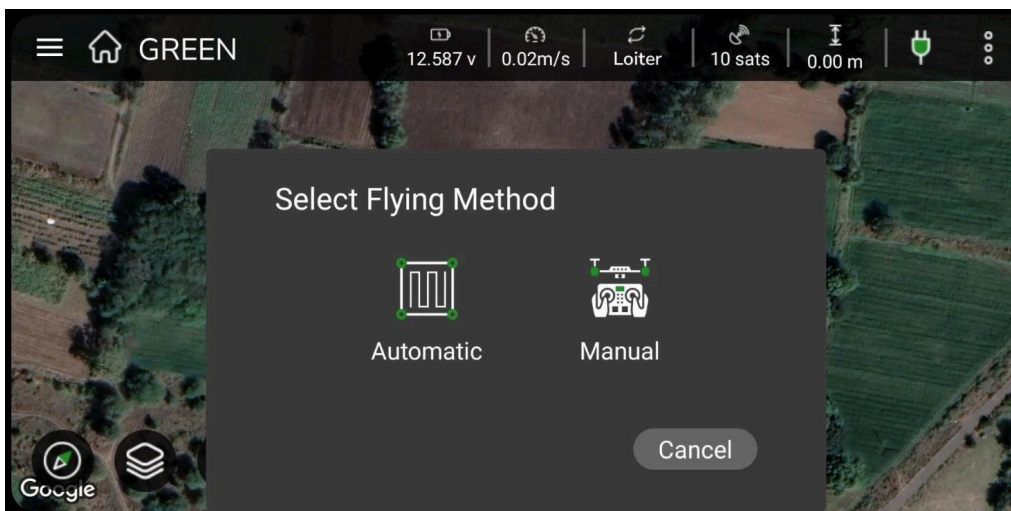

Figure 3.3.174: Selection of Flying Method

Flight Manual			
Pavaman Aviations Private Limited			
Issue No.	09	Version No.	1.9
Date	22/07/2024	Document Reference	PA - 8

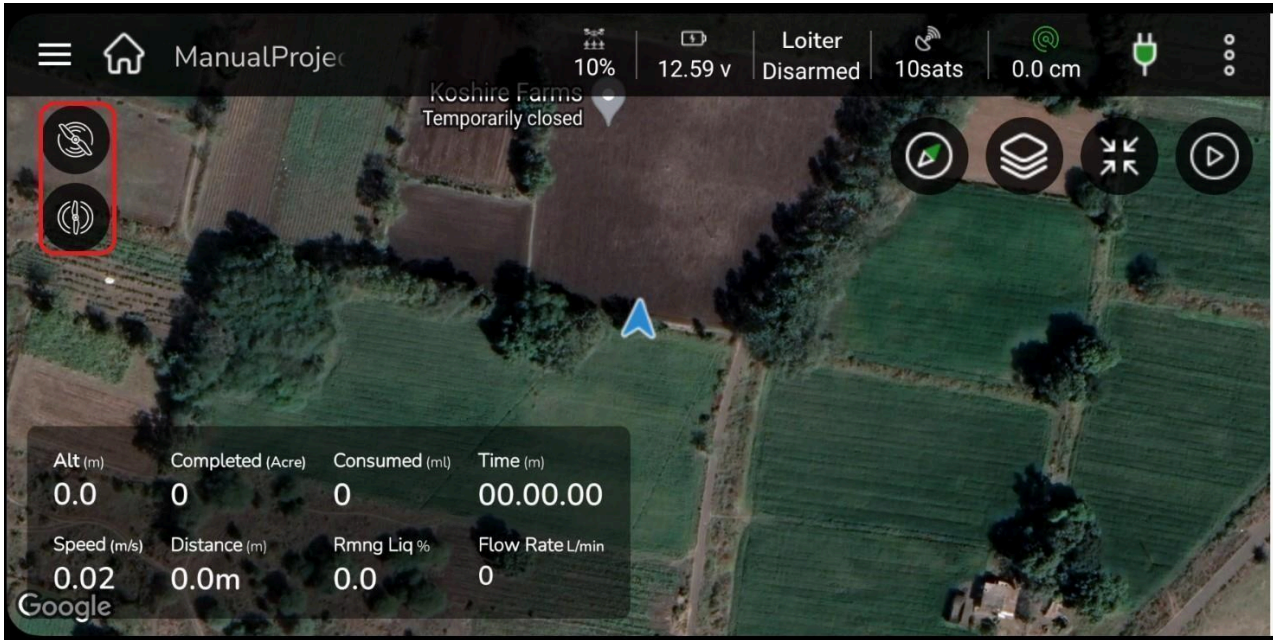

Figure 3.3.175: Arm and Disarm Navigation Bar on Flyview

Use the "Arm" command to start the flight. The user will get a message as "Arming Motors" on the flyview as shown.

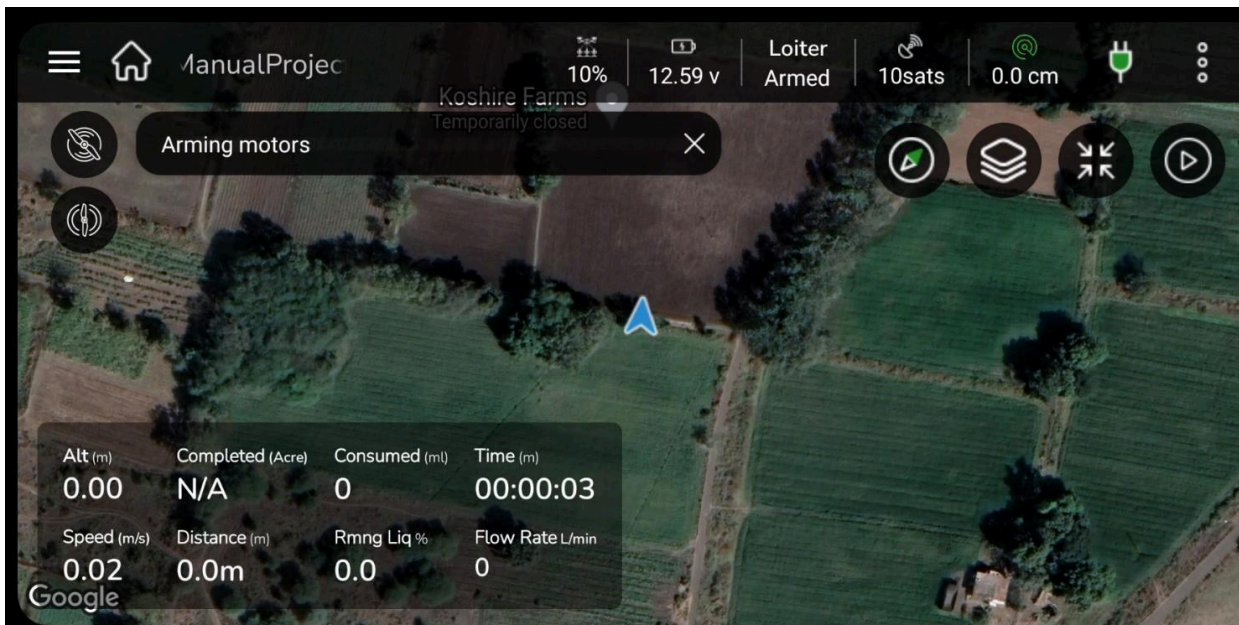

Figure 3.3.176: Arming Motors

Use the "Disarm" command to disarm and complete the flight with the safe landing of a drone. Live feed using T12 or MK15.

Flight Manual			
Pavaman Aviations Private Limited			
Issue No.	09	Version No.	1.9
Date	22/07/2024	Document Reference	PA - 8

The user may use T12 or MK15 on his RC to observe the flight very easily. A proper synchronization should be established, and the required parameters are to be set accordingly.

4.14. Report Generation

The details of every flight are to be preserved as evidence for various purposes. Sometimes these reports are required for following certain legal matters. Also, these can be used to improve the performance of the device. A report will be generated after every completed flight. The report will be stored on the local computer as well as the user can save it on the cloud if he has the account created on AeroMegh.

Reports of existing plans can be checked from the dashboard. Select the plan from the respective project. Select three dots from the right-hand side of the specific plan name.

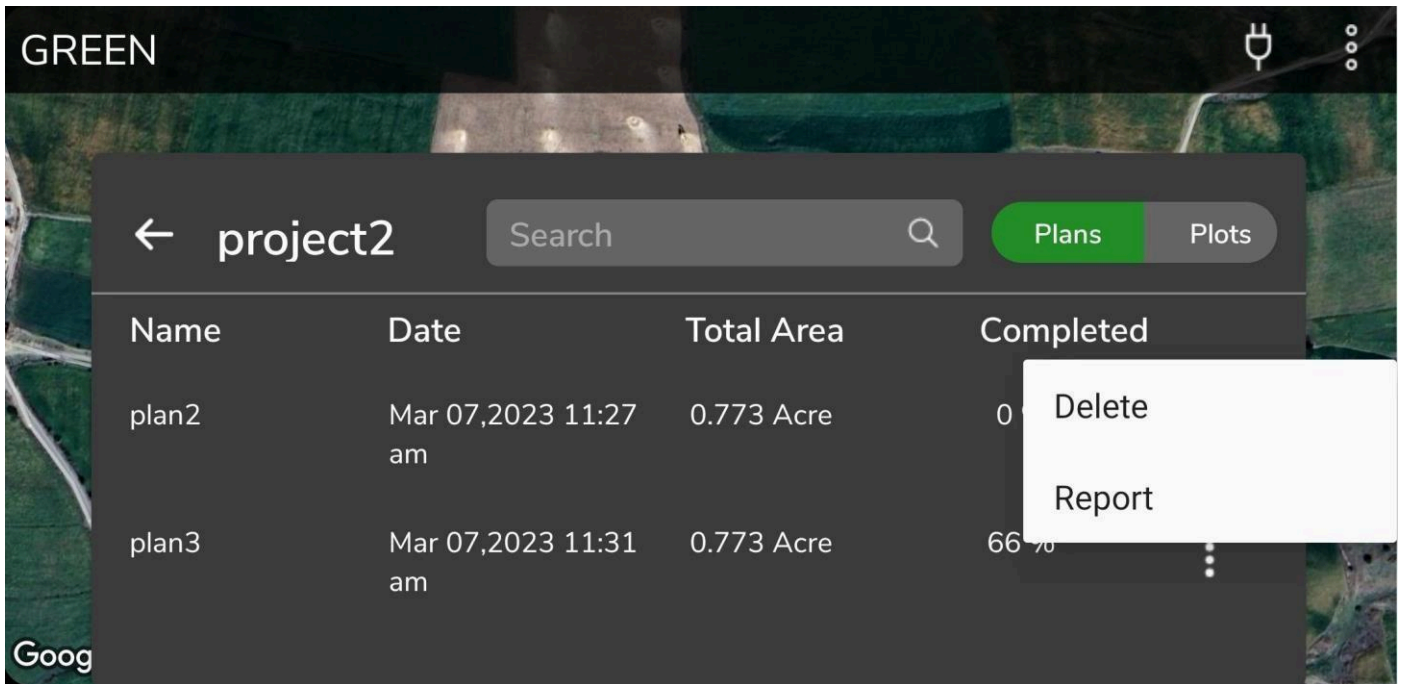

Figure 3.3.177: Check a Report

Click the "Report" option and a report will be displayed as shown:

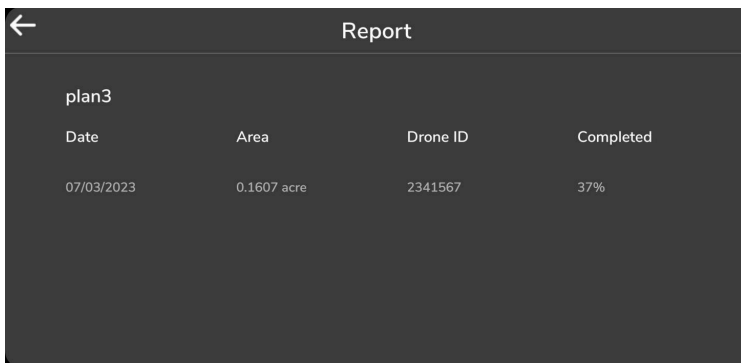

Figure 3.3.178: Report from Dashboard

Flight Manual			
Pavaman Aviations Private Limited			
Issue No.	09	Version No.	1.9
Date	22/07/2024	Document Reference	PA - 8

This report consists of details such as Date of flight

Area covered by the flight

Drone ID: Which drone is used for a flight.

Completed: The status of the flight is displayed as a percentage of completion of the flight.

Based on the percentage of completion, it is indicated that the flight is completed or has a resume remark. A resume remark is used in case of emergency. The flight can be completed from the resume marked on the plan. It will help to reduce the time of flight.

Field Report will be automatically generated after the successful completion of flight. The user must enter the details as shown in the image.

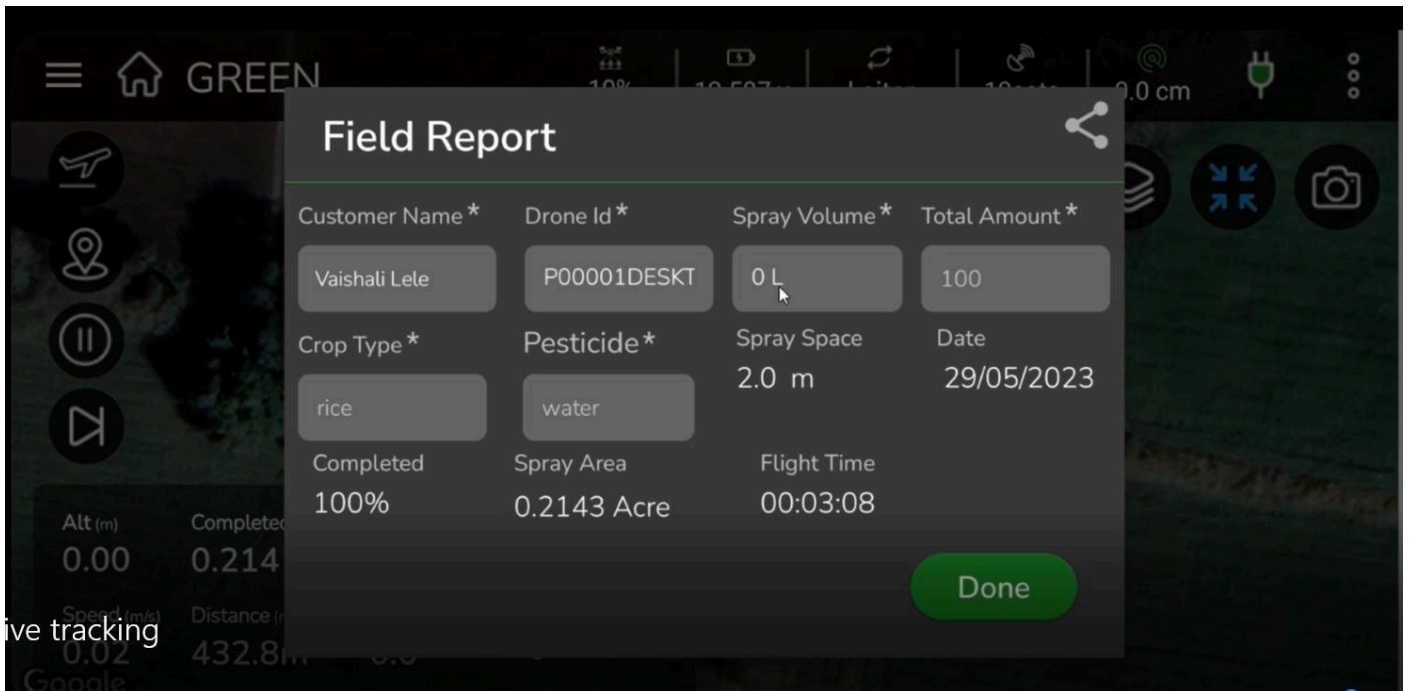

Figure 3.3.179: Field Report

The user may skip these two fields while generating a field report

Spray Volume: This is the capacity of a tank attached to a drone..

Total Amount: The total amount is which the pilot going to charge to the customer(Farmer)

Crop Type: This is required to cross-verify for altitude values.

Pesticide: Enter the details of the pesticide used for spraying.

Spray Space: The value of spray space is based on the spacing allotted while setting parameters before actual flying.

Date: The date of a flight will be considered automatically by the app.

Spray Area: It is automatically calculated and displayed on the screen.

Flight Manual			
Pavaman Aviations Private Limited			
Issue No.	09	Version No.	1.9
Date	22/07/2024	Document Reference	PA - 8

Completed: The status of the flight is displayed as the percentage of flights completed. The value will be determined automatically through AeroGCS GREEN.

Flight Time: Total time taken to complete the flight. This will be calculated automatically by the software. After filling in the necessary data in the report click on the "Done" button. The report will be saved for the respective plan.

The same report can be shared through different options such as Gmail, WhatsApp, etc.

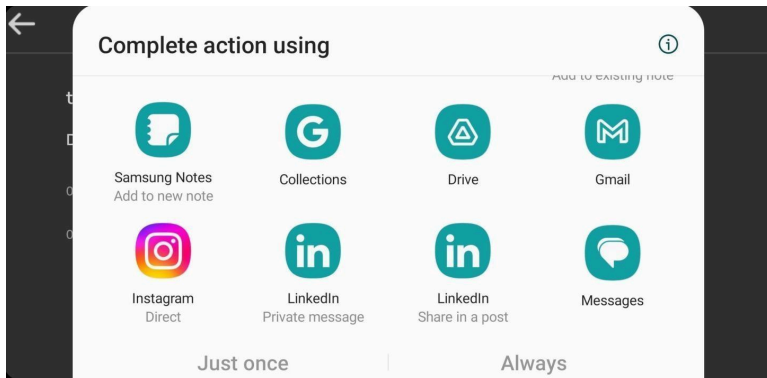

Figure3.3.180: Share report through app from Mobile

4.15. Landing Procedures:

4.15.1. Emergency Landing

In case of sudden climate change, high air speed, heavy rain and malfunction of drone due to motor alignment will cause the drone to fly in an uncontrollable manner. In these conditions the pilot should land the RPAS in the nearest land location or emergency landing point.

4.15.2. Return To Launch

Built-in feature Return-to-home, set the appropriate RTL landing location and altitude. The RTL function is a safety feature that guides the drone back to a safe and accessible landing location. The drone uses its take-off position as the Launch Point when it receives four or more GPS signals. It then uses real-time GPS coordinates and a compass to navigate its return flight. However, any interference with the Home Point position, GPS, or compass can affect the RTL function.

For Copter, the home position is set as the location where the vehicle was armed. This means that when an RTL is executed, the drone will return to the location where it was armed. To ensure the drone returns to the desired location, the operator should arm the vehicle in the desired return point or set up an alternative return point using a rallying point.

Flight Manual			
Pavaman Aviations Private Limited			
Issue No.	09	Version No.	1.9
Date	22/07/2024	Document Reference	PA - 8

4.16. Postflight Procedures:

4.16.1. Payload Removal, Data Backup And Storage

NO.	DESCRIPTION	CHECKLIST	REMARKS
1	After giving the command to disarm the machine through the transmitter, the motors should stop.	Yes () / No ()	
2	To remove the battery, stand behind the drone and first remove the left side of the battery, then the right side.	Yes () / No ()	
3	Handle the battery with care, as overheating may have occurred during flight if the pack is faulty or damaged.	Yes () / No ()	
4	Allow the motors to cool using the same method as for the battery packs, check the temperature of the motors beneath the propellers.	Yes () / No ()	
5	Take the temperature of each electronic component as part of your routine maintenance and repair checklists to ensure that parts are replaced when necessary, before a flight.	Yes () / No ()	
6	Generally, motors should be warm to the touch but not too hot to touch.	Yes () / No ()	
7	Check that motor temperature is within an acceptable range and consider factors such as load weight, flight length, and ambient site heat that can affect the temperature of motors as well as battery packs.	Yes () / No ()	
8	Turn off the transmitter, handle it gently and place it in the case where the antenna shouldn't get damaged.	Yes () / No ()	
9	Turn off the AeroGCS from the GCS.	Yes () / No ()	
10	Put the propeller holder back. Fold the arm joints and put the arms into arm holders	Yes () / No ()	
11	Once the battery is removed follow the payload maintenance procedure.	Yes () / No ()	
12	Record flight time, mission completed, and any remarks.	Yes () / No ()	

Flight Manual			
Pavaman Aviations Private Limited			
Issue No.	09	Version No.	1.9
Date	22/07/2024	Document Reference	PA - 8

13	Save the Data log, to analyse the Data and efficiency of the task.	Yes () / No ()	
14	Fold the arms of the Drone and place it in the Drone Case.	Yes () / No ()	

4.16.2. Maintenance Checks

Regular maintenance of UAS must be done to ensure that UAS is in good condition.

The following steps are designed for routine maintenance and can be applied as frequently as necessary, but it is most efficient to perform maintenance on a post -flight basis. That way, UASs always remain in better condition.

Logbook has to be maintained for all the maintenance works.

■ **Structural Inspection**

- Clean frame of mud and dirt.
- Inspect frame for cracks.
- Check for any loose screws. If loose, tighten them.
- Check propellers for damage like cracks or deformation.
- Check propellers whether they are free spinning.
- Check motors for dust, debris, and obstructions.
- Check the state of wiring and solder joints.
- Check whether the landing gear has any deformation or cracks.
- Inspect antennae.
- Check whether any error displays in the control station.

■ **Battery Checks**

- Inspect charger for visible damage.
- Inspect battery packs for bulges.
- Inspect the battery for possible battery fluid leaks.

■ **Payload Checks**

- Check if the pesticide tank has deformation.
- Check pump and sprinkler systems are proper.

Flight Manual			
Pavaman Aviations Private Limited			
Issue No.	09	Version No.	1.9
Date	22/07/2024	Document Reference	PA - 8

5. Emergency Procedures

Emergency procedure is the responsibility to be proficient with the aircraft operational manual provided by the vendor before any flight operations are conducted. It is also a best and safe practice to prepare an Emergency Checklist. The drone should always be prepared to execute an emergency procedure in instances where there is a lost link, loss of GPS, or there are other aircraft or obstructions in the flight path. After the drone has safely landed, it should be in maintenance.

S.No	Failsafe	Visual alert	Audio alert	Time taken for GCS	Action
1	Battery failsafe	Battery failsafe	Battery failsafe	immediately	RTL triggered
2	Radio Failsafe	Communication lost, drone disconnected	Communication lost, drone disconnected	10sec	RTL triggered
3	GCS Failsafe	Communication lost, drone disconnected	Communication lost, drone disconnected	10sec	RTL triggered
4	Geo fence failsafe	Fence Breach	Fence Breach	immediately	RTL triggered

5.1. Failsafe Triggers and RTL Procedure:

Scenario: The drone triggers the Return to Launch (RTL) function due to failsafe conditions.

Action for the Pilot:

- Monitor the drone's status on the controller and identify any warning alerts.
- Confirm the RTL procedure is activated and observe the drone's response.

Drone (RPA) Response:

- The RPA will directly return to home at the current altitude following the shortest path.

Safety Considerations for Pilots:

- Be aware of the current altitude RTL procedure and any obstacles in the drone's flight path.
- Ensure a safe and clear airspace for the drone's return to home.
- Reacting to Unplanned Failsafe Conditions:

Flight Manual			
Pavaman Aviations Private Limited			
Issue No.	09	Version No.	1.9
Date	22/07/2024	Document Reference	PA - 8

Drone Behavior in Unplanned Failsafe Scenarios:

- The RPA may enter RTL mode due to various unplanned failsafe conditions (e.g., signal loss, low battery).
- Follow the same steps as planned failsafe, monitoring the RPA's response and ensuring a safe flight back home.

Safety Precautions for the Pilot:

- Keep a safe distance from the RPA and any obstacles during RTL, ensuring compliance with local airspace regulations and safety guidelines.

Additional Safety Measures:

- **Avoiding Hazards During RTL:**
 - Pilots should avoid interfering with the RPA's return path to prevent collisions or unsafe conditions.
- **Navigational Safety:**
 - Observe local airspace conditions and make adjustments to the RTL path to avoid populated areas or hazardous locations.

Contingency Planning:

- **Emergency Landings:**

Plan for emergency landings in safe and open areas if the RPA fails to return home or encounters critical issues.

- **Loss of Communication:**

Establish a procedure for potential loss of communication between the controller and RPA.

- **Post-Emergency Reporting:**

After any failsafe or emergency scenario, ensure proper reporting, maintenance, and debriefing procedures.

5.2. Loss Of Communication

In the event of a loss of connection with the GCS or loss of connection with UAS with radio, the drone will automatically activate the RTL function. The GCS will also give a visual warning to alert the operator of the loss of connection.

- Lost link is defined as the loss of command-and-control link between the UAS and the ground station. There are two types of links that are relevant in this discussion.

<h1>Flight Manual</h1>			
<h2>Pavaman Aviations Private Limited</h2>			
Issue No.	09	Version No.	1.9
Date	22/07/2024	Document Reference	PA - 8

- The uplink refers to the transmissions of command instruction from the ground station to the aircraft.
- The downlink refers to the transmission of telemetry and sensor data from the aircraft to the ground station.

RTL (Return to Launch) function which will be triggered, on loss of connection either with radio or with the GCS.

As a result of both datalinks loss there will be an RTH function which will be triggered if no communication is established within 10 seconds.

Upon entering FAILSAFE mode, the RPA will fly directly back to the Home Position (Launch area) following the shortest path. If the RPA is below the specified RTH Altitude, it will first remain in its current position while ascending to the predetermined altitude. This altitude should be set to be well above the highest obstacle in the flight operation area. After ascending to the set RTH altitude, the RPA will follow the shortest path to home location and land.

GCS Failure

In case the GCS fails and the RPA still has connection with the radio, it will still go into failsafe mode and trigger RTL if no communication is established within 10 seconds.

The RPA will first climb to a predefined safe altitude as defined by the user, which shall be above the height of the highest nearest obstacle and then follow the shortest path back to the home location and initiate landing at the home location.

The GCS will showcase a visual warning by popping up a message with no communication link. As there is no telemetry data coming down. Once the RPA re-establishes the connection with GCS, it will showcase a message of GCS failsafe cleared and mode will be shown as RTL and the RPA will continue the RTL procedure.

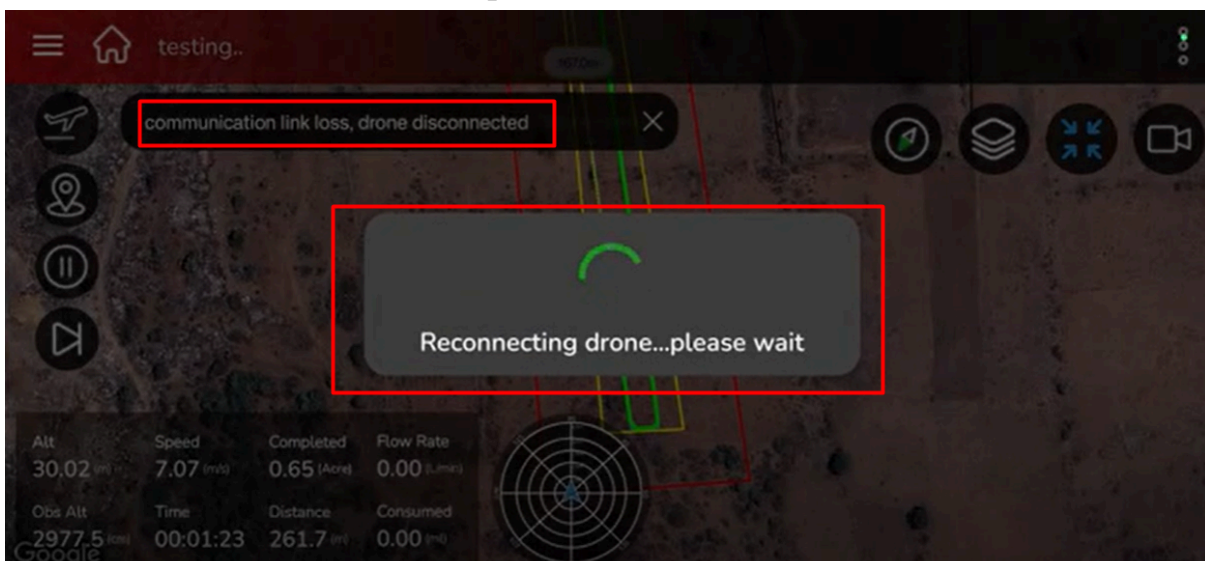

Flight Manual			
Pavaman Aviations Private Limited			
Issue No.	09	Version No.	1.9
Date	22/07/2024	Document Reference	PA - 8

Fig 28: Dashboard showing 'GCS failsafe cleared'

Flight Manual			
Pavaman Aviations Private Limited			
Issue No.	09	Version No.	1.9
Date	22/07/2024	Document Reference	PA - 8

Radio Failure.

In case the RPA losses connection with the remote control the RPA will trigger the pre-programmed failsafe feature.

In case of loss of link with the radio, GCS will show a visual message and aural message and the RPA will trigger RTL if no communication is established within 10 seconds.

The RPA will first climb to a pre-defined safe altitude as defined by the user, which shall be above the height of the highest nearest obstacle and then follow the shortest path back to the home location and initiate landing at the home location.

The GCS will showcase a message of Radio failsafe and mode will be showed as RTL.

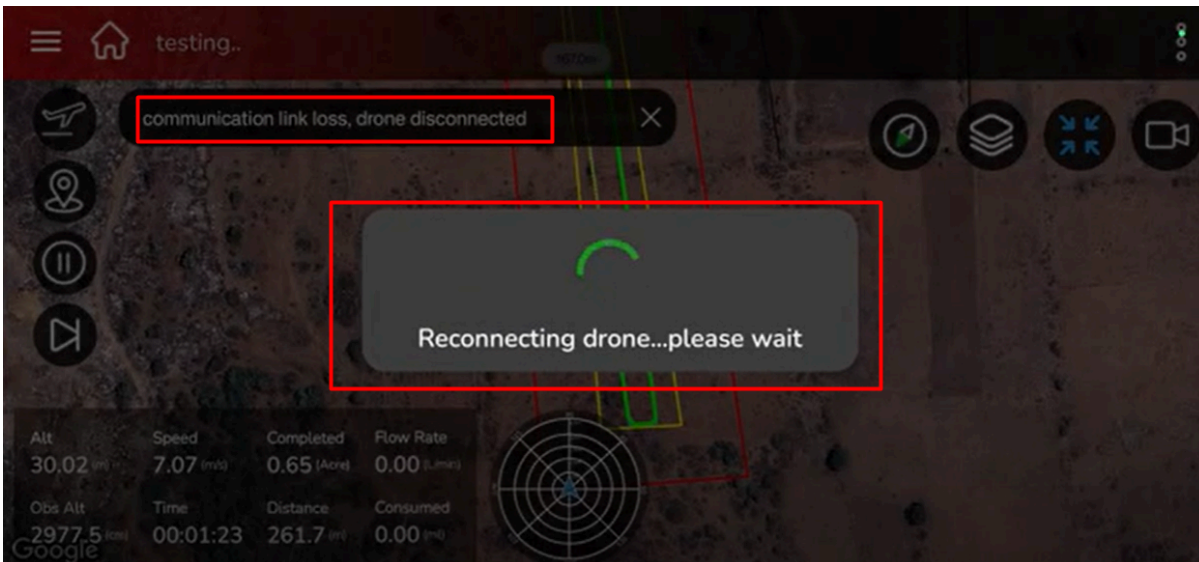

Fig 29: Dashboard showing 'Communication link lost'

5.2.1. Loss Of Control / Stability Mid- Air

When a drone experiences loss of stability in the air, such as uncontrollable yawing, disorientation, or wobbling, the first step is to activate the Return to Launch (RTL) mode through the radio controller or Ground Control Station (GCS). If the RTL function is not working, the drone should be landed immediately using the remote control (RC).

5.2.2. Low Battery Failure

When the drone's battery level reaches a certain threshold, a warning will appear on the visual display, and the drone will automatically initiate the Return to Launch (RTL) and fly back to the home point.

Flight Manual			
Pavaman Aviations Private Limited			
Issue No.	09	Version No.	1.9
Date	22/07/2024	Document Reference	PA - 8

- The RPA will trigger failsafe mode if the battery voltage value reaches or drops below (42V). In case of a battery low voltage, the RPA will automatically trigger RTL.
- The RPA will follow the shortest path back to the home location (Where it was powered on) at current altitude and initiate landing at the home location.
- The GCS will show a message of battery failsafe and the mode will show as RTL.
- If the battery power is reduced to second level voltage then the RTL will be initiated immediately.
- Upon entering FAILSAFE mode, the RPA will fly directly back to the Home Position (Launch area) following the shortest path at the same altitude.

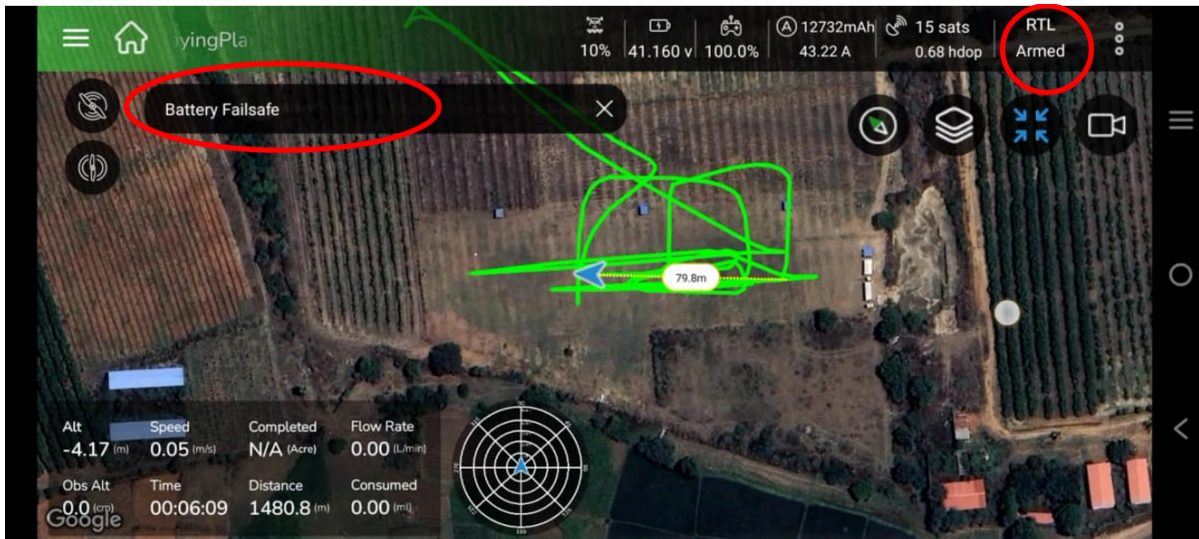

Fig 17: Dashboard showing 'Low battery warning'.

5.2.3. LOSS OF VISUAL CONTACT WITH THE RPA

This RPA is certified to fly only in VLOS conditions. Flying outside of these parameters can cause loss of Radio Control link or separation from obstacles, terrain or other aircraft. It is therefore imperative that the pilot maintains visual contact with the RPA.

5.2.4. EMERGENCY LANDING

In case of sudden climate change, high air speed, heavy rain and malfunction of the drone due motor alignment will cause the drone to fly in an uncontrollable manner. In these conditions the pilot should land the RPAS in the nearest land location or emergency landing point.

5.2.5. SUDDEN CHANGE IN WIND CONDITIONS

A sudden increase in wind strength can catch a RPA pilot unaware. Increased winds will add time to the flight and drain the battery faster. The pilot should be especially aware if the RPA is operating far downwind of the pilot.

Flight Manual			
Pavaman Aviations Private Limited			
Issue No.	09	Version No.	1.9
Date	22/07/2024	Document Reference	PA - 8

5.2.5.1. FLIGHT CONTROLLER SYSTEM FAILURES

Unexpected behaviour can be due to erroneous sensor readings, degraded GPS signal reception, or compass issues. TEJAS is equipped with redundancies of major systems, but the PIC should not continue flight after an error has been reported. Potential system failures include Flight controller IMU; GPS/compass; attitude telemetry and stabilisation.

5.2.6. IMU FAILURE

If an IMU error occurs, the Autopilot will alert the PIC and will switch IMU control to one of the redundant modules.

5.3. GPS FAILURE

If a GPS error or failure occurs, the autopilot will alert the PIC and will automatically switch to ALT HOLD mode. The RPA will no longer be able to hold its current horizontal position, but it should not climb or descend uncontrollably. It is also possible that there is a significant degradation of GPS signal strength, which is not recognized by the autopilot. In this case, the RPA may begin an uncontrolled movement while still in POS HOLD MODE. The pilot incharge may manual control the RPA through RC and land it safely.

Flight Manual			
Pavaman Aviations Private Limited			
Issue No.	09	Version No.	1.9
Date	22/07/2024	Document Reference	PA - 8

5.4. COMPASS FAILURE

If a compass error or failure occurs, the RPA will enter an uncontrolled circular movement (toilet-bowling). It may also tilt in a direction other than the one input on the RPS (doglegging). The autopilot should alert the PIC and automatically switch to ALT HOLD mode. It is possible that the autopilot will not automatically exit

LOITER mode. In this case the PIC should recognise the uncontrolled movement and exit LOITER manually. The RPA will on longer be able to hold its current position or perform a safe RTL failsafe.

5.4.1. INCAPACITATION OF PILOT

In the event of the pilot becoming incapacitated during the flight operations, either the payload operator or observer should take control of the RPS.

5.5. Geofence Breach

In case the RPA flies beyond the set geofence, the RPA will enter into the failsafe mode and trigger RTL immediately.

The RPA will first climb to a predefined safe altitude as defined by the user, which shall be above the height of the highest nearest obstacle and then follow the shortest path back to the home location and initiate landing at the home location.

The GCS will show a message of Fence breach and the mode will show as RTL.

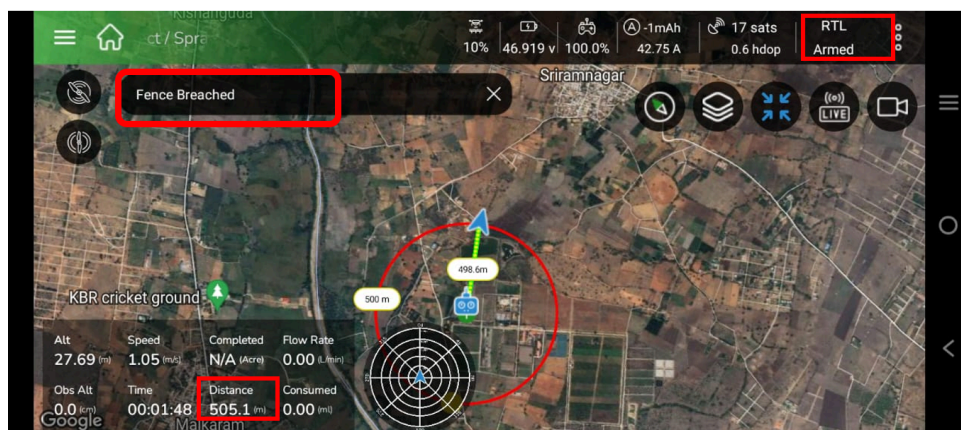

Fig 17: Dashboard showing 'Geofence breach'.

5.6. Emergency Shutdown

Emergency shutdown procedures for a drone in case of battery catching fire, or any fire accidents around the drone while flying, and wind turbulence during landing:

<h1>Flight Manual</h1>			
<h2>Pavaman Aviations Private Limited</h2>			
Issue No.	09	Version No.	1.9
Date	22/07/2024	Document Reference	PA - 8

■ **Overheating threshold:**

- If the edge LED of the motor starts to blink from solid green, the pilot shall land the UAS immediately and contact the support team of Pavaman Aviation.

■ **Current consumption exceeding the maximum threshold:**

- The continuous current consumption should not exceed 90 Amps. If the current consumption is going beyond 90 Amps continuously, the pilot shall land the UAS immediately and contact the support team of Pavaman Aviation

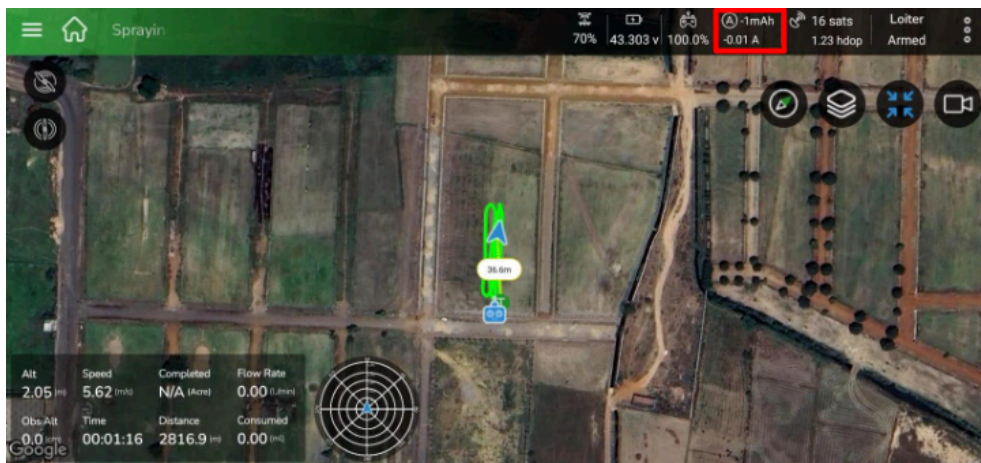

■ **Fire accidents around the drone while flying.:**

- If there is a fire accident around the drone while flying, immediately bring the drone back to the ground.
- Land the drone as safely and as quickly as possible.
- Once the drone is on the ground, disconnect the battery and move the drone away from the fire.
- Do not attempt to fly the drone again until the cause of the fire has been determined and corrected.

■ **Wind turbulence during landing**

- If the drone is experiencing wind turbulence during landing, immediately bring the drone back to higher altitude to get out of turbulent air.
- Fly the drone back to the take-off point, or a nearby safe location.
- Once the drone is back in the air, try to fly the drone to a higher altitude to get out of the turbulent air.
- Once the drone is out of the turbulent air, bring the drone back to the ground safely.
- Land the drone as safely and as quickly as possible.

Flight Manual			
Pavaman Aviations Private Limited			
Issue No.	09	Version No.	1.9
Date	22/07/2024	Document Reference	PA - 8

6. Maintenance

6.1. Routine Maintenance Schedule

■ **Daily Maintenance**

Maintenance that takes place daily or after every flight is termed as daily maintenance. Visual Inspection should be carried out on a drone after every flight. Components that need to undergo daily maintenance are

- Verify that all arms are securely attached to the centre frame and that the Arm waterproof rings are locked in place.
- Check for any motion between the locking cap of the arm and the folding mechanism.
- Inspect the centre airframe for structural anomalies and loose or missing parts.
- Inspect the Locking cap of arm for any damage or wear to the carbon tubes, paying close attention to the junctions at each end.
- Check for motion between each motor mount and boom, and between the motor bell and base.
- Spin the motors by hand to check for smooth rotation and inspect the motor bells for any dents or scratches.
- Inspect the propellers for correct attachment to the hub with respect to the rotation of the motor, e.g., (CW Propeller- to- CW motor), pitch play and wear.
- Verify that the propellers are clear of surrounding structures and other propellers as they rotate through their full range of motion.
- Test and log the voltage of each battery pack and inspect the batteries for signs of damage or swelling.
- Inspect the battery connectors and leads for wear or damage and ensure all batteries are securely attached to the battery tray.
- Verify that the battery plate is securely attached to the tank top and that the landing gear is correctly oriented and attached to the airframe.
- Check that the GPS and control link antennas are securely fastened and correctly oriented.
- Verify that the RPA indication lights on the end of each boom are functioning properly.
- Inspect the payload attachment points and ensure that clamps are in place, if used.
- Check the payload level.
- Verify that all antennas are in good condition and correctly oriented.
- Inspect the control sticks of the transmitter for free movement and check for dust or debris.

Flight Manual			
Pavaman Aviations Private Limited			
Issue No.	09	Version No.	1.9
Date	22/07/2024	Document Reference	PA - 8

■ Maintenance Schedule

Inspections that are performed before and after every flight need not require a maintenance team. But after every 10 flights, it is recommended to consult the maintenance team if you have encountered a hard landing or crash. If there is a smooth flight, the drone can be sent to maintenance after 50 flights. Below is the table on what interval the inspections can be done, which will be followed by the maintenance team.

S.NO	NAME OF THE COMPONENT	EVERY FLIGHT	AFTER 1 DAY	AFTER 1 MONTH
1	Frame(body, hood)		✓	✓
2	Arms(carbon tube, aluminium tubes, folding parts, locking cap, arm accessories kit)		✓	✓
3	Landing gear(vertical, horizontal, fixed seat of landing gear)	✓		✓
4	Motors	✓		✓
5	Propellers	✓		✓
6	Flight controller			✓
7	Transmitter & receiver			✓
8	GPS			✓
9	FCS sensor			✓
10	Battery, battery plate, Velcro tape	✓		✓
11	pneumatic connectors(6*6 , 8*6, 12*8)		✓	✓

Flight Manual			
Pavaman Aviations Private Limited			
Issue No.	09	Version No.	1.9
Date	22/07/2024	Document Reference	PA - 8

12	XT connectors(60,90), BEC		✓	✓
13	Tank, pump, water tube,level sensor,Flowmeter		✓	✓
14	Screws		✓	✓

✓ - Scheduled Maintenance by Manufacturers.

✓ - Scheduled Maintenance by Operators.

❖ *Note: Battery must be replaced after 300 cycles.*

■ Payload Maintenance

- Pesticides when stored for a long-time result in corrosion. To prevent it, payload maintenance should be done after every flight.
- Wear protection gear while handling pesticides.
- Clean tank, nozzles, pneumatic connectors, and pump with fresh water.
- This cleaning is done by filling fresh water in the tank and allowing it to spray. This will eliminate pesticides and dust present in the payload system.
- Using a clean cloth, dry the tank and sprayers.
- Remove the nozzles from the connected tube. Clean the filter of the nozzles with a thin brush and water. Dry it before storage.

6.2. Maintenance Procedures

6.2.1. Battery Maintenance

- All cells in a LiPo battery should always maintain the same voltage.
- Always store your LiPo batteries at room temperature.
- After flight operation keep the battery in room temperature for minimum 5 minutes before charging.

■ Battery Storage

- Store the batteries in a protective bag when not in use this protects the pack from damage.
- Place the storage box on a cement concrete floor and horizontal clearance radius should be at least 2ft and vertical clearance should be at least 10ft.

Flight Manual			
Pavaman Aviations Private Limited			
Issue No.	09	Version No.	1.9
Date	22/07/2024	Document Reference	PA - 8

- Store the Battery packs in a low temperature room (less than 25 degree Celsius).
- Damage to a cell in a pack will permanently damage the pack and may cause a fire.
- Store the Fired battery in a cool, dry chamber to avoid smoke or flame.
- Fire extinguishers must be available during storage, transportation, and loading.
- Store the battery pack in nominal voltage 3.7V (22.2V across the pack). This makes the pack last longer and less volatile.
- Keep LiPo battery packs out of children's reach.
- Do not put batteries in pockets or near conducting metal where they can short out.
- Do not store, transport, or carry the battery where it can encounter sharp or metallic objects.
- Do not store LiPo batteries in extreme temperatures below 0°C or above 30°C.
- Always store LiPo packs in safe, non-flammable containers and away from combustible materials.
- Avoid bulk-storage in non-laboratory areas such as offices.
- Always store LiPo batteries partially charged. They maintain their level of performance over time and do not need to be cycled unless stored for more than 3-6 months ideally.
- Visually inspect battery storage areas at least weekly.

■ Battery Safety

- Don't place charging batteries on any surface that could catch fire, including soft combustible furniture.
- Don't expose your batteries to fire or excessive heat or allow them to get wet.
- Store them at room temperature and away from direct sunlight.
- Don't carry or store batteries with metal items to prevent short circuiting between the battery terminals.
- Protect your battery from strong impacts or sharp objects – for example don't drop them or carry them with other items inside a toolbox. It might not be obvious, but this could damage the protective circuits or dividers within the battery.
- Ensure you install the battery correctly (don't reverse the polarity).
- Do not short circuit the battery manually. Do not contact positive and negative terminals.
- Do not stab the battery with sharp metal manually.

6.2.2. Motor And Propeller Maintenance

- There should not be any bend in the power supply wire while folding arms.

Flight Manual			
Pavaman Aviations Private Limited			
Issue No.	09	Version No.	1.9
Date	22/07/2024	Document Reference	PA - 8

- There should not be any cuts on wire coatings/insulation.
- After every flight the temperature of the motor should be checked.
- Check the motor resistance with a multimeter. If the resistance is high, replace the motor.
- Check if soldered lead in the connector is proper with the help of pull.
- Check and tighten screws and bolts on the motor and propeller assembly
- Inspect the motor and propeller for physical damage such as cracks or bent blades
- Cleaning the motor and propeller, including removing any debris or dust
- Checking and adjusting the motor and propeller balance
- Checking and replacing worn or damaged motor and propeller bearings
- Checking and replacing worn or damaged motor and propeller shafts
- In case of electronic failure, troubleshooting and replacement of electronic components such as ESC and motor controller.

However, if the damage is severe or the issue is not resolved by the above steps, it is recommended to contact the manufacturer for further assistance and repair or replacement of the motor and propeller.

6.2.3. Payload Maintenance

- Power supply cable should not get compressed while fitting the frame.
- Check the pump resistance with a multimeter. If the resistance is high, replace the motor.
- Check if soldered lead in the connector is proper with the help of pull.

6.3. Troubleshooting Guide

■ Common issue

- The compass is not healthy.
- After the compass calibration is done. The UAS will not arm.
- The vehicle's home position is not visible in GCS.
- There will be lag while uploading a flight plan.
- The AeroGCS will show bad gps.
- RC2 is not neutral.

■ Solution

- The Compass needs to be calibrated on all orientations.

Flight Manual			
Pavaman Aviations Private Limited			
Issue No.	09	Version No.	1.9
Date	22/07/2024	Document Reference	PA - 8

- The issue for compass calibration can be solved by removing the battery so that the compass is calibrated and again plugging it in the drone.
- The vehicle home position is necessary before flying. To get the home position of the drone you require to close the app and unplug the battery and again plug it in the drone.
- To prevent bad Gps, the machine should not be operated under the tree.
- To rectify the RC2 value issue, we✓ need to check in AeroGCS whether the RC values are neutral.

6.4. Service And Support

Service centre locations

All the services and advanced maintenance will be done in the Pavaman Aviation Private Limited .

Address: 2nd floor,kapil kavuri hub,financial district,nanakaramguda,
Hyderabad,Telangana,500032.

7. Performance Data

7.1. Operational Envelope

In the operational envelope, data considered will be as per the data constrained in geo-fencing by the Pavaman Aviations. considering the safety and operational requirements for the agricultural applications. The Geofence feature is used in the GCS to limit the operation of UAS under the operational Envelope for that dedicated mission with a limit which the Pilot in command PIC can adjust according to requirement. More details are explained in the Internal flight test report. Operational limits are as follows: -

- Operating Condition : Visual Line of Sight and during daytime
- Operational Altitude: 30 m (AGL), restricted by geo-fencing
- Range: 500 m , restricted by geo-fencing
- Endurance without dispensing payload at MTOW condition : 9 mins
- Endurance with dispensing payload at MTOW condition : 18 mins
- Endurance without variable payload (empty tank): 19 mins
- Speed: 8 m/s,
- Temperature: 15°C to +50°C
- Wind Speed: 6 m/s

Flight Manual			
Pavaman Aviations Private Limited			
Issue No.	09	Version No.	1.9
Date	22/07/2024	Document Reference	PA - 8

The above operational envelope is applicable for normal as well as emergency conditions. Failsafe demonstrations were performed within the same operating envelope simulating the following emergency conditions:

1. RADIO FAILSAFE

Radio Failsafe is the failsafe mechanism which is useful when the drone is disconnected from the radio. If it happens then the drone automatically triggers the Return to Launch (RTL) and comes back to the home position and lands at the takeoff point.

2. GCS FAILSAFE

GCS Failsafe is the failsafe mechanism which is useful when the drone is disconnected from the GCS application. If it happens then the drone automatically triggers the Return to Launch (RTL) and comes back to the home position and lands at the takeoff point.

3. BATTERY FAILSAFE

Battery Failsafe is the failsafe mechanism. Its primary purpose is to ensure that when a battery reaches a critical level of charge (42 V). If it happens then the drone automatically triggers the Return to Launch (RTL) and comes back to the home position and lands at the takeoff point.

4. GEOFENCE FAILSAFE

Geofence Failsafe is the failsafe mechanism which is useful when the drone is travelling beyond the specified range or altitude (max range - 500m & max altitude - 30m or user specified range) which may cause damage/malfunction of the drone. If it happens then the drone automatically triggers the Return to Launch (RTL) and comes back to the home position and lands at the takeoff point.

S.No	Failsafe	Visual alert	Audio alert	Time taken for GCS	Action
1	Battery failsafe	Battery failsafe	Battery failsafe	immediately	RTL triggered
2	Radio Failsafe	Communication lost, drone disconnected	Communication lost, drone disconnected	10sec	RTL triggered
3	GCS Failsafe	Communication lost, drone disconnected	Communication lost, drone disconnected	10sec	RTL triggered
4	Geo fence failsafe	Fence Breach	Fence Breach	immediately	RTL triggered

7.2. Weight And Balance Information

Summary of different weights in TEJAS drone:

Sr No.	Weight	Reading
1	Single battery weight Battery set Weight	1.820 Kg 3.66 kg ± 50 g

Flight Manual			
Pavaman Aviations Private Limited			
Issue No.	09	Version No.	1.9
Date	22/07/2024	Document Reference	PA - 8

2	Fixed Payload	2.28 kg ± 50 g
3	Variable Payload	8 kg ± 50 g
4	Empty weight without battery and without payload	10.90 kg ± 150 g
5	Empty weight, battery and fixed payload	16.9 kg ± 150g
6	Empty weight + fixed payload + variable payload	21.24 kg ± 150g
7	Empty weight + battery weight + fixed payload + variable payload (AUW)	24.82 kg + 80g
8	Empty weight + battery weight + fixed payload + variable payload + Tolerance (MTOW)	24.9 Kg

7.3. Battery Life

The life of the battery is determined to be 300 cycles that means 300 charges and 300 discharges. It is concluded by testing the battery in a NABL accredited Lab.

7.4. Payload Performance

The Brushless water pump is approximately 3-5 times the life of an ordinary water pump. It can be used for more than 500 hours without worrying about pump damage, frequent replacement and any delay in operations. This helps to reduce after-sales repair and replacement costs. Pump is used to pump the liquid payload from the tank and raise sufficient pressure so that the liquid flows through the pipes and goes to the nozzle.

Pump has a rating of 150W with a flow rate of 5 L/min. Voltage rating is 12-14S(DC44-60.9V) with a rated pressure of 0.35 Mpa. Suitable for 12mm inner diameter water pipes. Motor Dimensions are 123 x 76 x 52 mm(LxBxH).

Specifications:

Product Name : Brushless water pump
COMBO-PUMP-5L-brushless-10A-14S-V1

Specifications:

Working Voltage	12-14S (DC44-60.9V)
Maximum Power	150W
Working Pressure	0.35Mpa
Working Current	≤2.5A
Data of opening	5L/min

Flight Manual			
Pavaman Aviations Private Limited			
Issue No.	09	Version No.	1.9
Date	22/07/2024	Document Reference	PA - 8

Protection Grade	IP67
Weight	388g(Approx, without wire, 338g)
Size	123x76x52mm
Fixed PWM throttle range	1050-1950 μ S



Figure 6.1: Schematic diagram of Pump.

7.5. Safety Information

The safety of agricultural drones used for spraying in India is of paramount importance to ensure the safety of the operators, the public, and the environment. Here are some safety guidelines for agri-drones used for spraying in India:

- **Operator Training:** The operator of the drone should be properly trained and certified to operate the drone safely.
- **Weather considerations:** Drones should not be flown in adverse weather conditions such as high winds, low visibility, or thunderstorms.
- **Flight Planning:** The operator should plan the flight path and conduct a pre-flight check of the drone and its systems. They should also have a plan in place in-case of an emergency.
- **Restricted areas:** The operator should be aware of the restricted areas where drone flight is prohibited and obtain necessary permissions before flying the drone.
- **Safe operation:** The operator should fly the drone at a safe distance from people, buildings, and other objects, and avoid flying over densely populated areas.
- **Safety equipment:** The operator should carry safety equipment such as fire extinguisher, first aid kit, and emergency contact list while operating the drone.
- **Maintenance:** The operator should regularly maintain the drone and its systems to ensure that it is in safe and proper working condition.
- **Spray liquid handling:** The operator should handle and store the spray liquids used for spraying in a safe and responsible manner and should comply with the regulations regarding the use of chemicals.

Flight Manual			
Pavaman Aviations Private Limited			
Issue No.	09	Version No.	1.9
Date	22/07/2024	Document Reference	PA - 8

- Safety first: The operator should always keep safety as the top priority and be prepared for any contingency that may arise during the flight.

It's important to note that these are general guidelines and rules may change in the future, it's important to stay updated with the latest regulations and guidelines issued by relevant authorities regarding the safe operation of agri-drones in India.

8. Safety Considerations

8.1. Risk Management

In India drones must be registered with the DGCA and have a unique identification number. To manage risks associated with drones, it is important to comply with the prevailing regulations and guidelines, as well as to conduct regular maintenance and safety checks on the drone. It is also important to have liability insurance to cover any potential damages or injuries caused by the drone.

8.2. Operating In Restricted Airspace

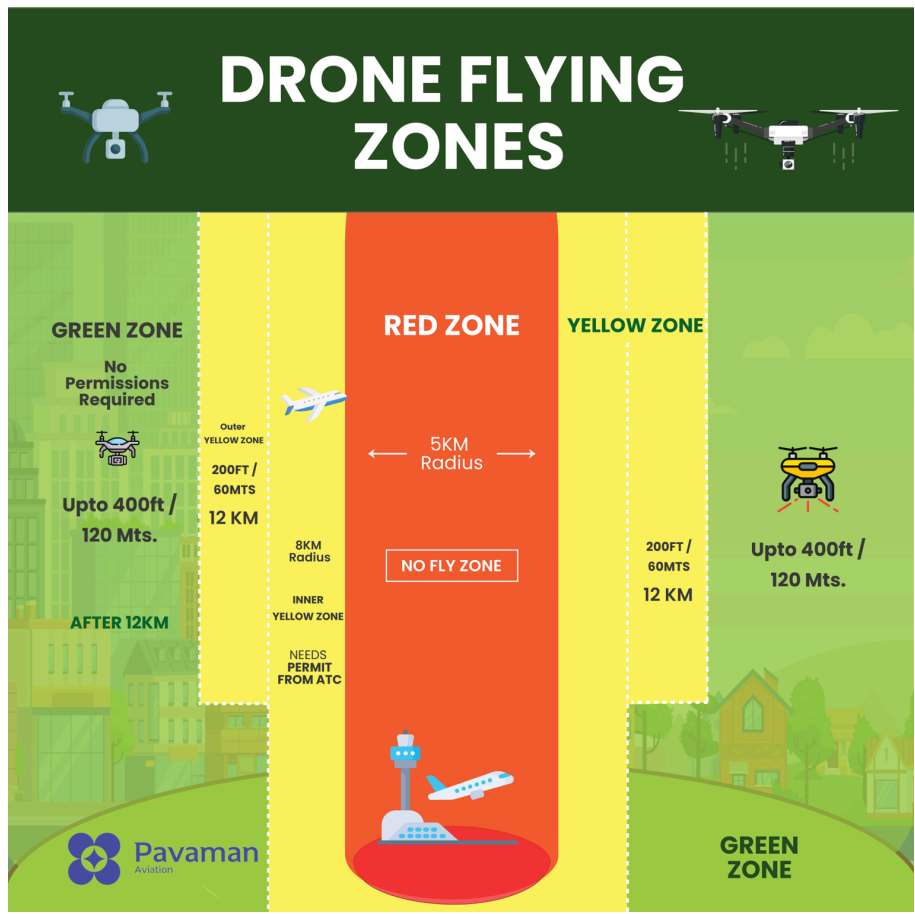

Flight Manual			
Pavaman Aviations Private Limited			
Issue No.	09	Version No.	1.9
Date	22/07/2024	Document Reference	PA - 8

8.3. Flight Termination Procedures

The flight termination procedure for a drone used for agriculture applications, such as spraying, will vary depending on the specific drone and the situation. Here are some general steps that may be involved in such a procedure:

- **Communication loss:** If the communication link between the drone and the ground control station is lost, the drone will likely be programmed to fly to a predefined location or return to its take-off location.
- **Battery low:** When the battery is low, the drone will automatically return to the take-off location or will land on the nearest safe location.
- **Emergency landing:** If there is an emergency that requires an immediate landing, the drone can be instructed to land immediately, or an automatic emergency landing function can be activated.
- **Abort mission:** The operator or the system can also trigger an abort mission command, in this case the drone will return to home point or nearest safe location.
- **Liquid Low:** When the drone variable payload is empty then the liquid level sensor will detect and any of the following Failsafe action can be triggered.(RTL,HOVER or do Nothing).

It's important to note that the drone should be equipped with safety features such as automatic return to Launch, and emergency landing mode, etc. It is also important to conduct regular maintenance and safety checks on the drone and to have proper procedures and protocols in place for emergency situations.

9. Technical Data:

9.1. Dimensions

Summary of all Dimensions in TEJAS

Sr No.	Measurement	Reading
1	TEJAS Folded Length	678 mm ± 10 mm
2	TEJAS Folded Breadth	762 mm ± 10 mm
3	TEJAS Folded Height	581 mm ± 10 mm
4	TEJAS unfolded Length	1844 mm ± 10 mm
5	TEJAS unfolded Breadth	2037 mm ± 10 mm

Flight Manual			
Pavaman Aviations Private Limited			
Issue No.	09	Version No.	1.9
Date	22/07/2024	Document Reference	PA - 8

6	TEJAS unfolded Height	581 mm ± 10 mm
7	M1 to M2 folded	861 mm ± 10 mm
8	M1 mid to M2 mid, unfolded	1413 mm ± 10 mm
10	Propeller to GPS horizontal distance	165 mm ± 10 mm
12	Propeller to Arm rod clearance	42 mm ± 5 mm
13	Propeller ground clearance	511 mm ± 10 mm
14	Propeller to hub distance	231 mm ± 10 mm
15	GPS to ground clearance	568 mm ± 10 mm
16	GPS to arm clearance	79 mm ± 5 mm
17	GPS to Hub distance	51 mm ± 5 mm
20	Propeller P1 to P4	82 mm ± 10 mm
21	Propeller P1 to P2	2037 mm ± 10 mm

Flight Manual			
Pavaman Aviations Private Limited			
Issue No.	09	Version No.	1.9
Date	22/07/2024	Document Reference	PA - 8

9.2. Rpa Drawings

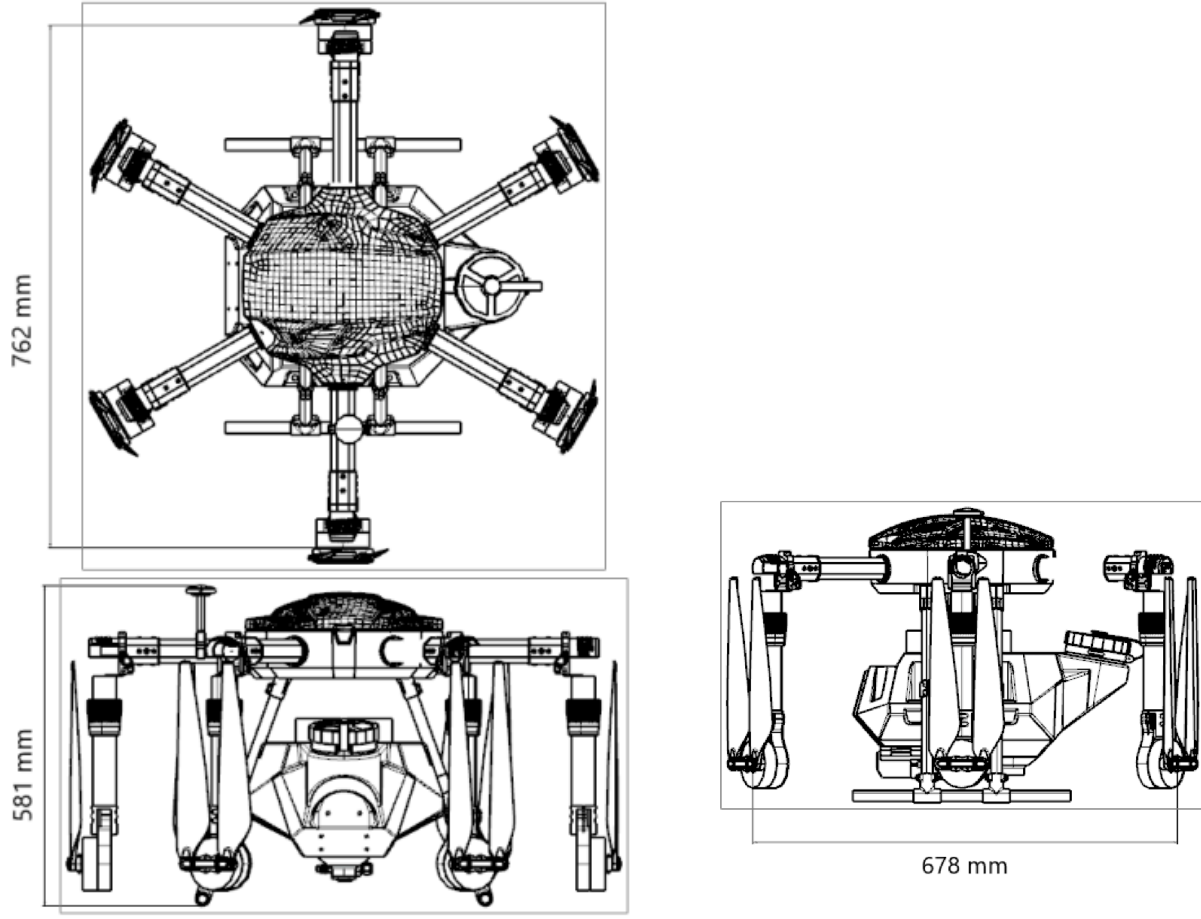

Fig 9.1: RPAS TOP, SIDE AND FRONT VIEW Folded.

Flight Manual			
Pavaman Aviations Private Limited			
Issue No.	09	Version No.	1.9
Date	22/07/2024	Document Reference	PA - 8

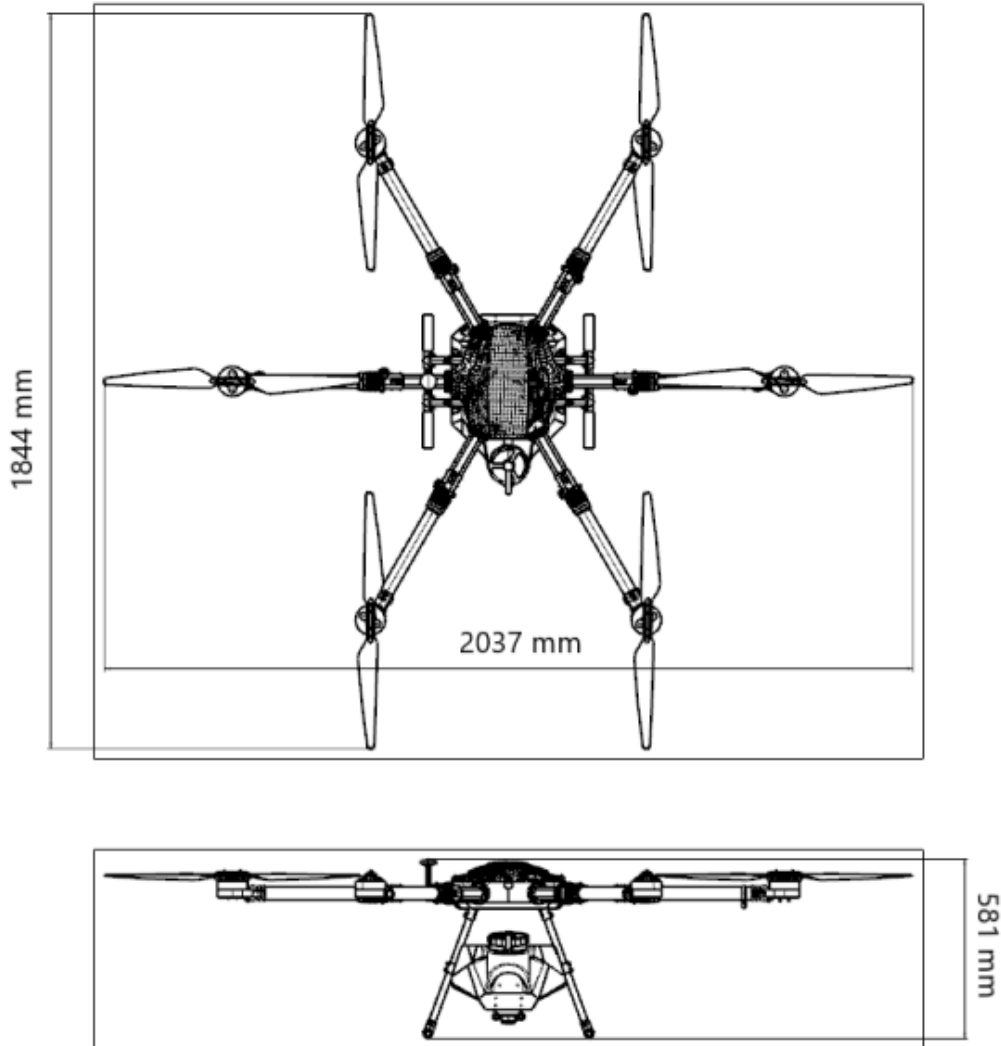

Fig 9.2 : RPAS TOP, SIDE AND FRONT VIEW Unfolded.

REFER THE RPAS CAD DRAWING ATTACHED BELOW AS ANNEXURE- 1

Flight Manual			
Pavaman Aviations Private Limited			
Issue No.	09	Version No.	1.9
Date	22/07/2024	Document Reference	PA - 8

9.3. Motor And Power Specifications

The X6 plus propulsion system, which integrates motor, ESC, propeller, and motor mount. The motor incorporates The FOC (Field Oriented Control)-based PMSM (Permanent Magnet Synchronous Motor) algorithm and has a lot of advantages like low noise, small size, high power density, low pulsating torque, and high control precision.

■ Troubleshooting:

TROUBLE	WARNING TONE	POSSIBLE CAUSE	SOLUTION
The ESC was unable to start the motor.	“BBB...” a single beep that repeats rapidly	The throttle stick was not moved to the bottom position.	Move the throttle stick to the bottom position.
The ESC was unable to start the motor.	“B, B, B...” a single beep that repeats (the time interval is 1 second).	There was no throttle signal output from the TH channel on the receiver.	Check if the transmitter & receiver are well bound; check if the throttle control cable has been properly plugged into the TH channel.
The power-on voltage was 18V.	“BB, BB, ...” a double beep that repeats (the time interval is 1 second.)	The battery voltage was too low.	Change a suitable and fully charged battery.
The power-on voltage was above 55V.	“BBB, BBB, ...” a triple beep that repeats (the time interval is 1 second).	The battery voltage was too high.	Change a suitable and fully charged battery.

■ Attention:

- Never get close to the high-speed rotating propeller & motor, otherwise you may get hurt.
- Check if all the parts are in good condition before use. If there exists any damaged part, please contact the manufacturer for replacement.
- Check if any screw for connecting the parts is loose and the motors are horizontal before each flight.
- You can wipe the motor with freshwater cloth after each flight to keep it clean.

Flight Manual			
Pavaman Aviations Private Limited			
Issue No.	09	Version No.	1.9
Date	22/07/2024	Document Reference	PA - 8

The specification of the motor are as follows

- Voltage : 6S-14S
- Power : 1500-2399W
- Operating Temperature : -10 to +50 degree Celsius
- Maximum Thrust : 11.8 Kg
- Diameter : 69.4*35.8
- Weight : 790

Flight Manual			
Pavaman Aviations Private Limited			
Issue No.	09	Version No.	1.9
Date	22/07/2024	Document Reference	PA - 8

9.4. Battery Specifications

Brand	Tattu
Capacity(mAh)	16000
Voltage(V)	22.2
Discharge Rate(C)	15C
Max Burst Discharge Rate(C)	30C
Configuration	6S1P
Net Weight (± 20 g)	1830
Length (± 5 mm)	190
Width (± 2 mm)	75
Height (± 2 mm)	63
Connector type	XT90 ANTI SPARK
Power Rating	355.5 Wh
Operating temperature	-10 to 55 °C

*Note: One set consists of two batteries of the above specification connected in series.

Flight Manual			
Pavaman Aviations Private Limited			
Issue No.	09	Version No.	1.9
Date	22/07/2024	Document Reference	PA - 8

9.5. Control And Communication Description Specifications

T12 telemetry system is used to control and communicate the UAS. T12 transmitter has 12 channels with frequency ranging from 2.400 to 2.4833 GHz. It is supported by FHSS technology with dual antenna dual mode. Communication range for this system is about 20 km as claimed by Skydroid, even though the range of TEJAS is restricted up to 500m as it is intended for agricultural spraying and to be operated in VLOS operations only . Receiver has an operating voltage of 4.5-5.5V. AeroGCS firmware is compatible with this system.



Fig 22: T12 Telemetry System

T12 Transmitter Functions		
S. No	Description	Function
1	Antenna	Transmitting signal to receiver
2	Toggle Switch 1	No Function
3	Toggle Switch 2	Flight mode switching
4	Toggle Switch 3	Spraying
5	Toggle Switch 4	RTL/RTH
6	Left Stick (X1, Y1)	Primary Yaw, throttle, arming
7	Right Stick (X2, Y2)	Roll, Pitch
8	Reserved switch	No function
9	Little stick (X3, Y3)	Secondary Yaw

<h1>Flight Manual</h1>			
<h2>Pavaman Aviations Private Limited</h2>			
Issue No.	09	Version No.	1.9
Date	22/07/2024	Document Reference	PA - 8

10	Power switch	ON/ OFF
11	USB1 / Video output	Data transmission
12	power level lights	Indicates the battery level of the unit
13	USB2/ Charging/ Data Link	Charging and Data transfer
14	Push Switch A	No function
15	Push Switch B	No function
16	Push Switch C	No function
17	Push Switch D	No function

Specification

Specification:

Weight	490g(controller), 26g(receiver), 15.6g(camera)
Channel	12
Working Voltage	3.7V
Working Current	170mA
Battery Capacity	4000mAh
Endurance	25hours
Frequency	2.400GHz-2.4833GHz
Communication Technology	FHSS
Transmission Distance	10km
Signal Output	SBUS, PWM, I2C

Using Environmental Conditions

1. Environment temperature: -10 °C ~ +55 °C.
2. Storage temperature: -25 °C ~ +70 °C.
3. Relative humidity: no more than 85%.
4. Atmospheric pressure: 86 kPa to 106 kPa.
5. The use of the site is not allowed to explode dangerous media, the surrounding media should not contain corrosive metals and insulating gas and conductive media, not allowed to be filled with water vapor and serious mold.
6. The place of use should have facilities to protect against rain, snow, wind, sand and ash.

Flight Manual			
Pavaman Aviations Private Limited			
Issue No.	09	Version No.	1.9
Date	22/07/2024	Document Reference	PA - 8

9.6. Payload Specifications

This UAS system is capable of spraying 8 L of pesticide. There is a 10 L tank for the purpose along with 4 spraying outlets.

Payload total weight is 8 kg.

TEJAS weighs MTOW 24.9 kg with the spray payload.

Components of Payload	Specifications	Quantity/capacity
Nozzle bar kit	High pressure, fan shaped atomization.	4 Nos
Pneumatic connectors	ø6 x ø6 mm coupler	4 Nos
Pneumatic connectors	ø6 x ø6 x ø8 mm T-connector	2 Nos
Pneumatic connectors	ø8 x ø8 x ø12 mm T-connector	1 Nos
Pneumatic connectors	ø12 x ø12 mm Elbow Connector	1 Nos
Pump	5liter, Max Voltage : 50.4V	1 Nos
Liquid flow metre & level sensor	5V	1 Nos (each)
Pneumatic tubes	ø6mm, ø8mm & ø12mm	8(4+2+2) Nos
Tank with battery plate Containing water & pesticide mixture	Varies with crop	8 litres

The purpose of the payload system present in TEJAS is to spray water-pesticide mixture on the crop. To facilitate spraying following components are included in payload system where each having their own function:

- Nozzles/Sprayer: 4 Sprayers are used to spray the water & pesticide mixture. It consists of a filter which doesn't allow large size dirt to pass through it.
- Pneumatic coupler: Couplers are connectors that connect same diameter tubes. There are two different dimension couplers used in this drone. They connect tubes of radius

Flight Manual			
Pavaman Aviations Private Limited			
Issue No.	09	Version No.	1.9
Date	22/07/2024	Document Reference	PA - 8

6mm to 6mm which are located between sprayer to connector and sprayer, and 12mm to 12mm which is located between tank and pump.

- **Pneumatic T-connectors:** Pneumatic t-connectors are used to connect 3 tubes of different dimensions. T connectors (ø12 x ø8 x ø8; and ø8 x ø6 x ø 6 mm) are used to connect the pump to the sprayers
- **Pump:** It accelerates the flow of liquid and ensures to send fluid through all the tubes.

Flight Manual			
Pavaman Aviations Private Limited			
Issue No.	09	Version No.	1.9
Date	22/07/2024	Document Reference	PA - 8

9.7. Operation

■ Operation

- Stay away from the rotating propellers and motors.
- The take-off weight must not exceed 24.9 kg (taking off at sea level).
- Always maintain visual line of sight of your aircraft.
- NEVER stop the motors mid-flight.
- DO NOT answer incoming calls during flight.
- DO NOT fly under the influence of alcohol or drugs.
- During the Return-to-Home procedure, you can adjust the altitude to avoid obstacles.
- In the instance of a Low Battery Warning, land the aircraft at a safe location.
- Always keep your hands on the remote controller so long as the motor is still spinning. Power off the aircraft before turning off the remote controller after landing.

9.8. Data logging

TEJAS uses the Pixhawk cube orange plus as its flight controller. Pixhawk cube orange plus flight controller has the capability inbuilt to log all the flight parameters at a speed of 1 Hz. The flight logs are stored in binary format in the memory card of the flight controller. These logs can be downloaded using the logs option in the GCS.

The parameters can be viewed in any open source flight data viewer.

Tejas contains FC with a memory card with 8 GB data storing capacity.

It can store up to a maximum of 499 log files.

The following parameters are logged in the memory card:

1. Events
2. Altitude , Speed , Range , Location, Failsafe, Battery Voltage, Battery Current, Signal Strength, Vibration Levels, Sensor Health, Control Input and Output, Number of satellites, HDOP, VDOP, Accelerations, Flight Modes, Maximum Bank Angle, Maximum fence altitude and range.

Flight Manual			
Pavaman Aviations Private Limited			
Issue No.	09	Version No.	1.9
Date	22/07/2024	Document Reference	PA - 8

10. UAS Logbook

TEJAS

Agri Drone OPERATIONAL LOG

MISSION/FLIGHT PLAN			
Date		Aircraft name	
Planned time		UIN number	
Estimated mission duration		Mission purpose	
Location			
Mission description			
OPERATOR DETAILS			
Pilot name			
Phone number		RP licence number	
Address			
Visual observers			

MISSION/FLIGHT RECORD							
	Launch time	Take off location	Landing time	Landing location	Payload	Battery voltage	Flight notes
Flight 1							
Flight 2							
Flight 3							
Flight 4							
Flight 5							

Flight Manual			
Pavaman Aviations Private Limited			
Issue No.	09	Version No.	1.9
Date	22/07/2024	Document Reference	PA - 8

Flight 6								
MISSION NOTES								

Signature of pilot

Signature of Visual observer

Flight Manual			
Pavaman Aviations Private Limited			
Issue No.	09	Version No.	1.9
Date	22/07/2024	Document Reference	PA - 8

BATTERY CHARGING LOGBOOK																						
Battery serial No:-																						
Before charging									After charging								Type of cha rgi ng	UI N	Cy cle	Ch arg ed by	m Ah fill ed	Re ma rks
Da te	Tot al Vol tag e	Cel 11	Cel 12	Cel 12	Cel 13	Cel 14	Cel 15	Cel 16	Tot al Vol tag e	Cel 11	Cel 12	Cel 12	Cel 13	Cel 14	Cel 15	Cel 16						

Flight Manual			
Pavaman Aviations Private Limited			
Issue No.	09	Version No.	1.9
Date	22/07/2024	Document Reference	PA - 8

Appendices:

1. Contact Information for Service and Support

ADDRESS: 2nd floor, kapil kavuri hub, financial district, nanakramguda, rangareddy -500032, Telangana

CONTACT DETAILS: 8465859571

EMAIL ID: vijay.veeramallu@pavaman.in

COMPANY WEBSITE: <https://pavaman.in>

2. Recommended Reading and Resources

- The Drone Rules, 2021
<https://www.dgca.gov.in/digigov-portal/jsp/dgca/homePage/viewPDF.jsp?page=InventoryList/headerblock/drones/Drone%20Rules%202021.pdf>
- Drone (Amendment) Rules, 2022
[https://www.dgca.gov.in/digigov-portal/jsp/dgca/homePage/viewPDF.jsp?page=InventoryList/headerblock/drones/Drone%20\(Amendment\)%20Rules%202022.pdf](https://www.dgca.gov.in/digigov-portal/jsp/dgca/homePage/viewPDF.jsp?page=InventoryList/headerblock/drones/Drone%20(Amendment)%20Rules%202022.pdf)
- TEJAS; Maintenance manual

Flight Manual			
Pavaman Aviations Private Limited			
Issue No.	09	Version No.	1.9
Date	22/07/2024	Document Reference	PA - 8

Annexure- 1

CONTENTS:

1. TOP , SIDE AND FRONT VIEW - ARMS UNFOLDED

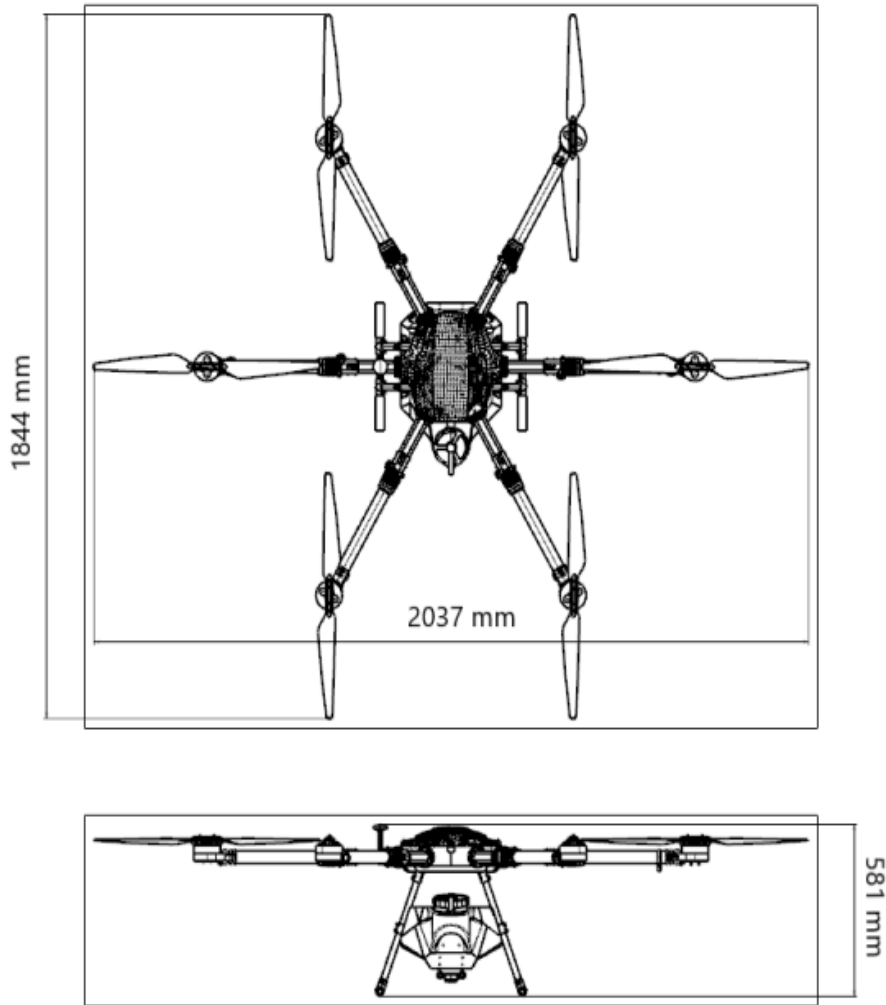

Unfolded View

Flight Manual			
Pavaman Aviations Private Limited			
Issue No.	09	Version No.	1.9
Date	22/07/2024	Document Reference	PA - 8

2. TOP , SIDE AND FRONT VIEW - ARMS FOLDED

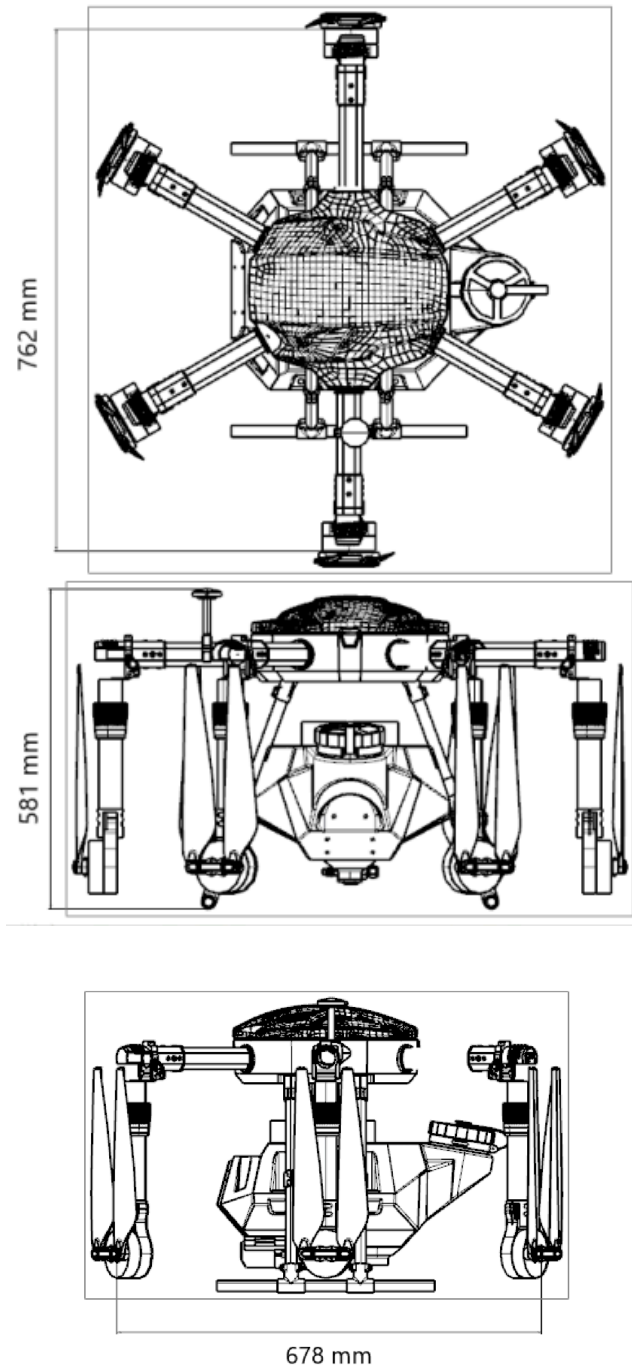

Flight Manual			
Pavaman Aviations Private Limited			
Issue No.	09	Version No.	1.9
Date	22/07/2024	Document Reference	PA - 8

3. ISOMETRIC AND TRIMETRIC VIEW

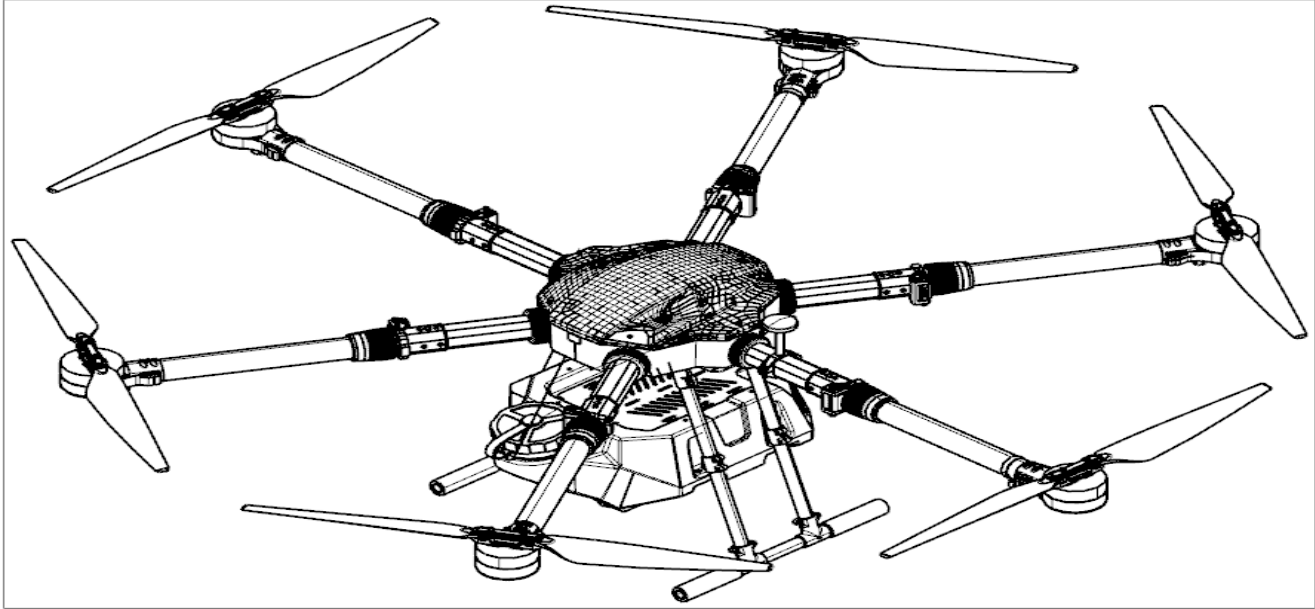

Isometric View

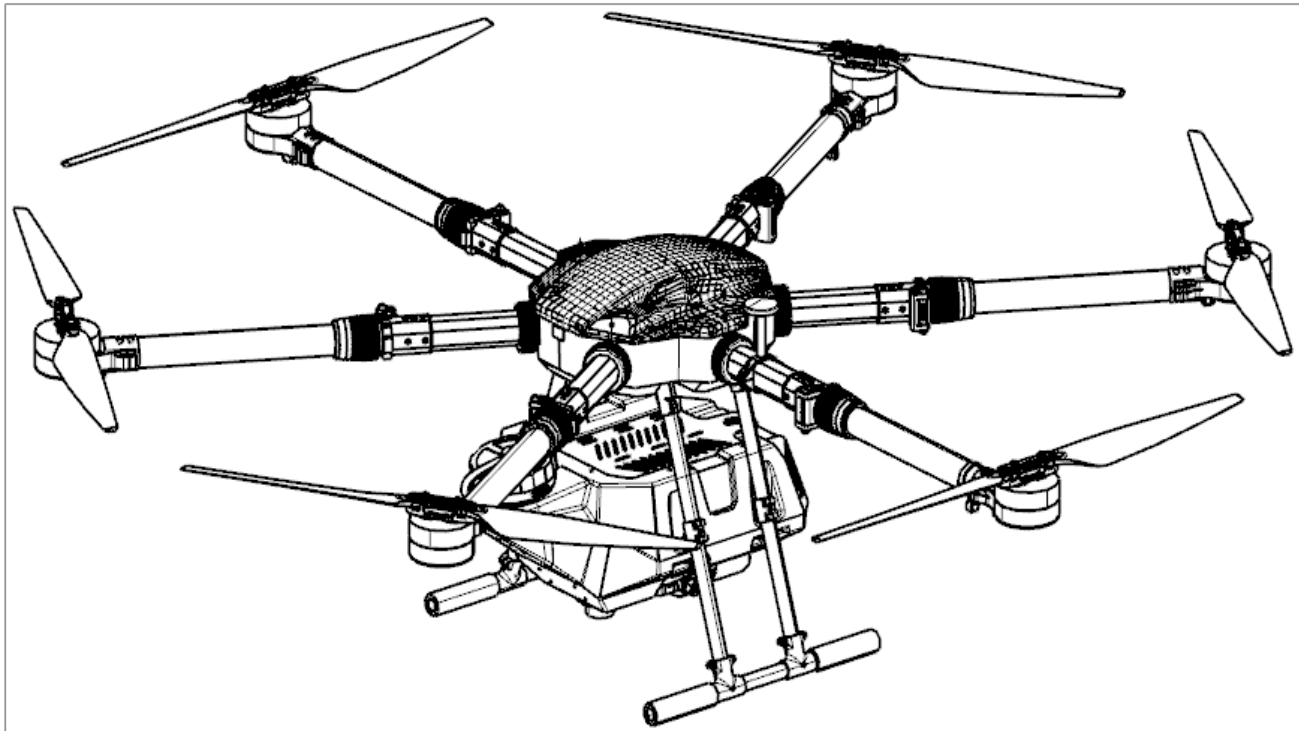

Trimetric View

Flight Manual			
Pavaman Aviations Private Limited			
Issue No.	09	Version No.	1.9
Date	22/07/2024	Document Reference	PA - 8

Annexure- 2

Life of UAS components

Component Name	Life
Airframe	9000 hours
Propellers	500 hours
Battery	300 hours
Landing gear	3000 landings
Landing gear joint 1	9000 hours
Landing gear joint 2	9000 hours
Arm folding mechanism	9000 hours

Flight Manual			
Pavaman Aviations Private Limited			
Issue No.	09	Version No.	1.9
Date	22/07/2024	Document Reference	PA - 8

Annexure- 3

- Flashing anti-collision strobe lights
 - No Flashing anti-collision strobe lights are not required by RPA as it is only to be flown in day time. It is not recommended to take- off during night time.
- Actuators
 - No actuators are required on RPA.
- Servo Controllers
 - No servo controllers are required on RPA.
- SSR Transponder
 - No SSR transponder are required in RPA.
- Detect and avoid capability.
 - No detect and avoid capability is available on RPA.
- Barometric Equipment
 - No barometric equipment is required in RPA.
- RFID & GSM Sim card
 - No rfid & gsm sim card is required on RPA.
- Susceptibility to HIRF
 - Not applicable as it is not to be flown in HIRF areas.
- IP Certification
 - As the TEJAS is recommended not to be flown in rainy conditions, it is not applicable.